

GROSS LOAD CAPACITY WHEN USED AS A WEIGHT CARRYING HITCH: 2,000 LBS. TRAILER WEIGHT & 200 LBS. TONGUE WEIGHT.

*****DO NOT EXCEED VEHICLE MANUFACTURER'S RECOMMENDED TOWING CAPACITY.*****

WARNING: ALL NON-TRAILER LOADS APPLIED TO THIS PRODUCT MUST BE SUPPORTED BY AUXILIARY STABILIZING STRAPS.

**** FAILURE TO PROPERLY SUPPORT NON-TRAILER LOADS WILL VOID PRODUCT WARRANTY****

HAVING INSTALLATION QUESTIONS? CALL TECHNICAL SUPPORT AT 1-800-798-0813

Parts List			
ITEM	QTY	PART NUMBER	DESCRIPTION
1	2	CM-11280-TS	ROUND TUBE .875 OD x .156 A-513 DOM
2	4	1/2"	CONICAL TOOTHED WASHER
3	2	1_2 - 13 x 7 HEX	HEX BOLT
4	6	CM-SP50	.250 x 1.00 x 1.50" ROUND HOLE SPACER
5	2	1/2 - 13 x 2 1/2	HEX BOLT
6	2	FW12	FW, 12, ZP
7	2	1/2-13	HEX NUT

TOOLS REQUIRED	
3/4" WRENCH	
3/4" SOCKET	
8" EXTENSION	
SOCKET WRENCH	
TORQUE WRENCH	

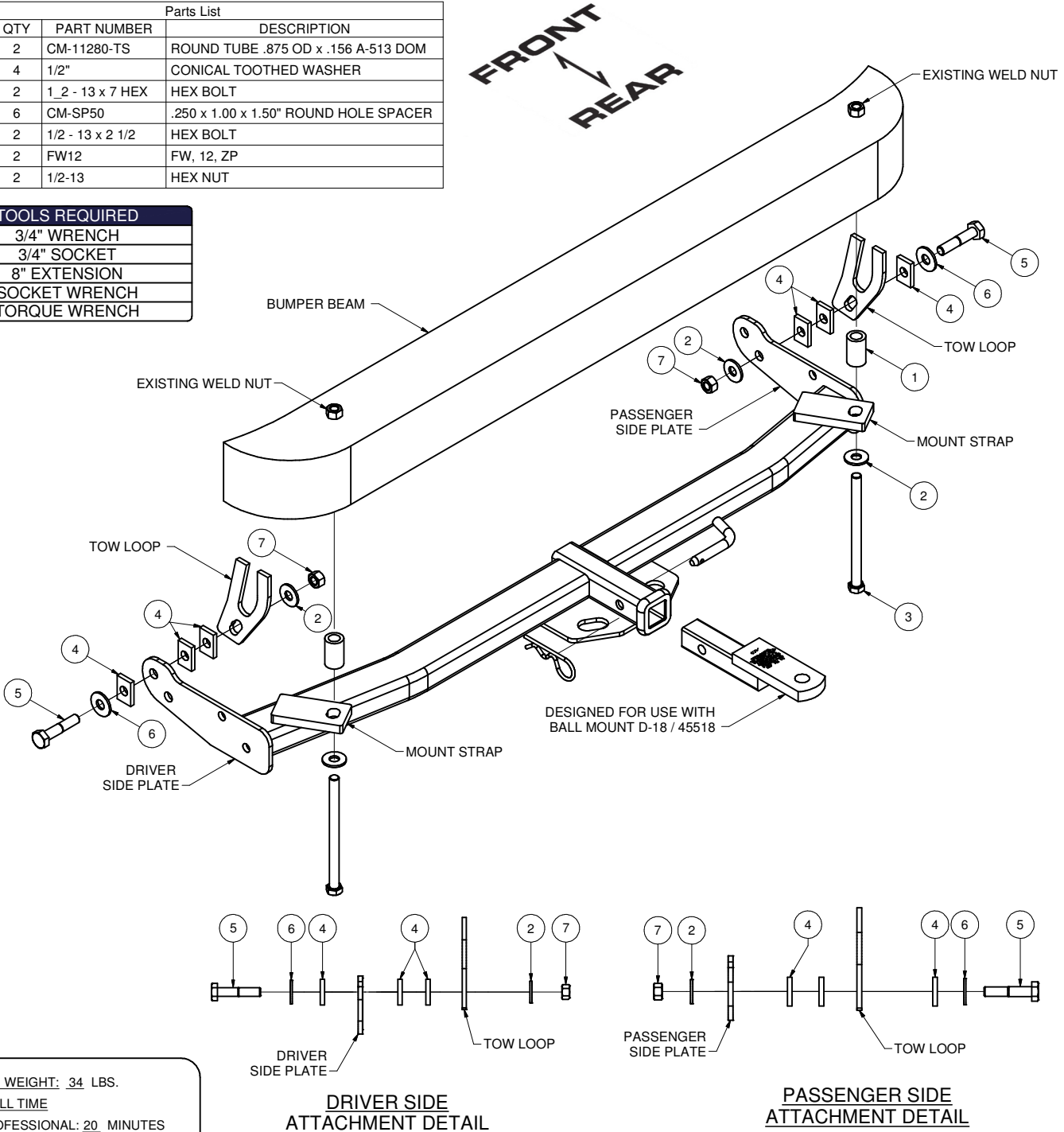

HITCH WEIGHT: 34 LBS.
 INSTALL TIME
 PROFESSIONAL: 20 MINUTES
 NOVICE (DIY): 40 MINUTES
 INSTALL NOTES:
 - NO DRILLING REQUIRED

NOTE: USE CM-SP50 SPACER (ITEM NO. 4) AS NEEDED.

PERIODICALLY CHECK THIS RECEIVER HITCH TO ENSURE THAT ALL FASTENERS ARE TIGHT AND THAT ALL STRUCTURAL COMPONENTS ARE SOUND.

Curt Manufacturing Inc., warrants this product to be free of defects in material and/or workmanship at the time of retail purchase by the original purchaser. If the product is found to be defective, Curt Manufacturing Inc., may repair or replace the product, at their option, when the product is returned, prepaid, with proof of purchase. Alteration to, misuse of, or improper installation of this product voids the warranty. Curt Manufacturing Inc.'s liability is limited to repair or replacement of products found to be defective, and specifically excludes liability for incidental or consequential loss or damage.

HAVING INSTALLATION QUESTIONS? CALL TECHNICAL SUPPORT AT 1-800-798-0813

1. Raise the hitch into position and loosely secure it to the outside of the driver side tow loop using the top hole in the driver side plate. Use the bottom hole in the passenger side plate to secure the hitch to the inside of the passenger side tow loop.
2. Rotate the hitch rearward aligning the holes in the mount plates with the holes in the bumper beam. Install 1/2-13 x 7.00" bolts and conical toother washers through the mounting plates and spacers into the weld nuts in the bumper beam as shown.
3. Torque all hardware to 110 ft-lbs.

PERIODICALLY CHECK THIS RECEIVER HITCH TO ENSURE THAT ALL FASTENERS ARE TIGHT AND THAT ALL STRUCTURAL COMPONENTS ARE SOUND.

Curt Manufacturing Inc., warrants this product to be free of defects in material and/or workmanship at the time of retail purchase by the original purchaser. If the product is found to be defective, Curt Manufacturing Inc., may repair or replace the product, at their option, when the product is returned, prepaid, with proof of purchase. Alteration to, misuse of, or improper installation of this product voids the warranty. Curt Manufacturing Inc.'s liability is limited to repair or replacement of products found to be defective, and specifically excludes liability for incidental or consequential loss or damage.