

**11491****SCION xD 1.8L SINGLE EXHAUST**

10/15/2012

GROSS LOAD CAPACITY WHEN USED AS A WEIGHT CARRYING HITCH: 2,000 LBS. TRAILER WEIGHT &amp; 200 LBS. TONGUE WEIGHT.

**\*\*\*DO NOT EXCEED VEHICLE MANUFACTURER'S RECOMMENDED TOWING CAPACITY.\*\*\***

WARNING: ALL NON-TRAILER LOADS APPLIED TO THIS PRODUCT MUST BE SUPPORTED BY AUXILIARY STABILIZING STRAPS.

**\*\* FAILURE TO PROPERLY SUPPORT NON-TRAILER LOADS WILL VOID PRODUCT WARRANTY\*\***

HAVING INSTALLATION QUESTIONS? CALL TECHNICAL SUPPORT AT 1-800-798-0813

Parts List			
ITEM	QTY	PART NUMBER	DESCRIPTION
1	2	5_8 - 11 x 2 HEX	HEX BOLT
2	4	3/8-16 X 1 1/2	HEX BOLT
3	2	5/8-11	HEX FLANGE NUT
4	4	HFN3816	HEX FLANGE NUT
5	4	3/8"	WASHER
6	2	5/8"	WASHER WIDE

TOOLS REQUIRED	
FLAT HEAD SCREWDRIVER	
RATCHET	
12mm SOCKET	
9/16" SOCKET	
15/16" SOCKET	
9/16" BOXED END WRENCH	
15/16" BOXED END WRENCH	
TORQUE WRENCH	

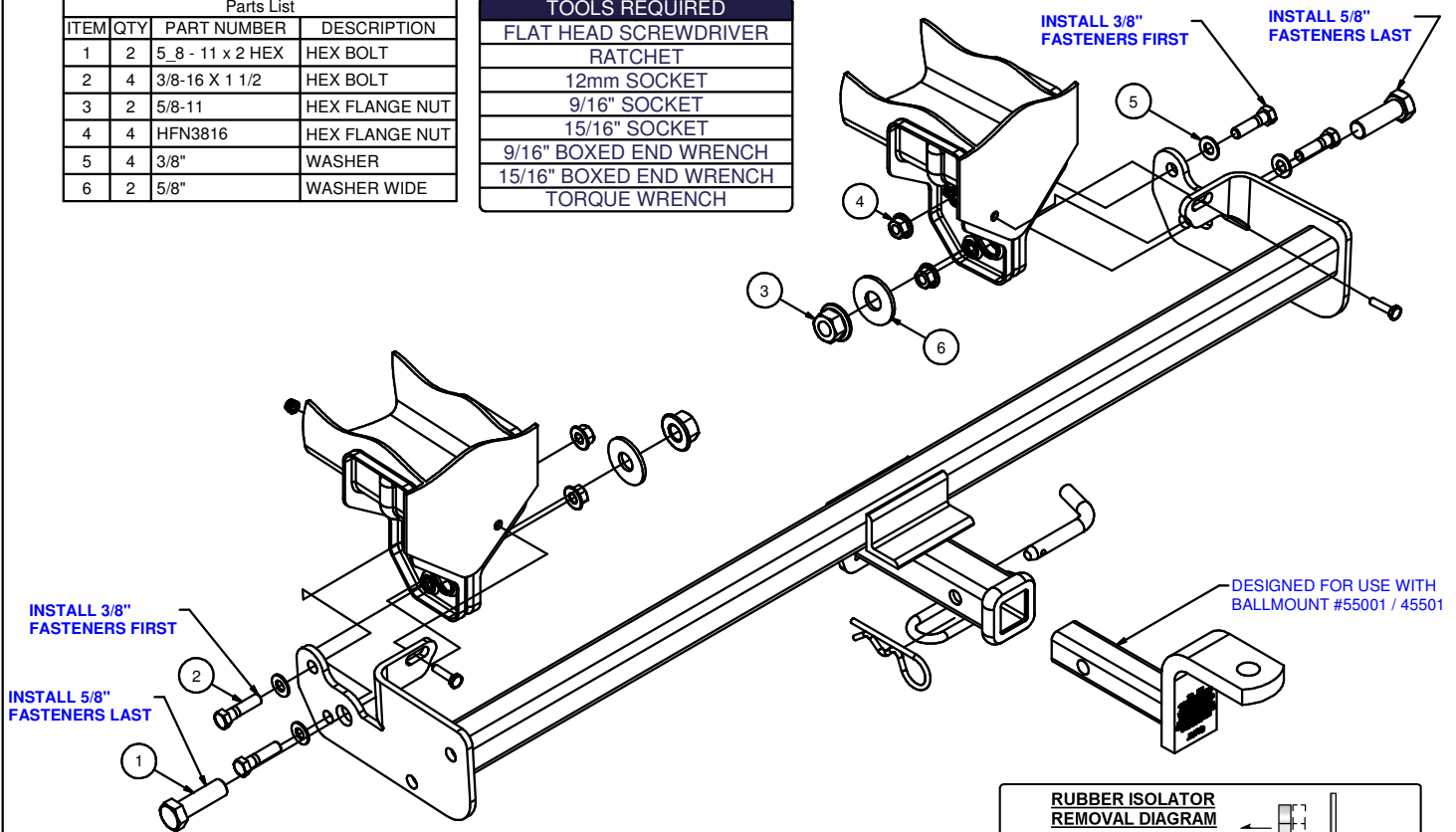

HITCH WEIGHT: 26 LBS.

**INSTALL TIME**

PROFESSIONAL: 35 MINUTES

NOVICE (DIY): 70 MINUTES

**INSTALL NOTES:**

- LOWER EXHAUST
- UNFASTEN LOWER FASCIA
- NO DRILLING REQUIRED

**FRONT**  
↑  
**REAR**

**RUBBER ISOLATOR REMOVAL DIAGRAM**

This technique can be used if and Exhaust Hanger Removal Pliers is not available.

Using a 5/8" open end wrench, slide the wrench up to the rubber isolator, cradling the hanger rod as shown. Next place the flat edge of a pry bar between the wrench and the hanger stop or hanger rod. Then simply rotate the pry bar toward the wrench to remove the rubber isolator.

Note: Using a spray lubricant or soapy water on the hanger rod and the rubber isolator helps removal.

**INSTALLATION STEPS**

1. Remove underbody panel by removing (7) push-button fasteners (if present) and return to owner.

2. Remove (2) 8mm existing fasteners from frame as shown.

3. Lower exhaust by removing (3) rubber isolators.

**(NOTE: Spraying a lubricant or soapy water on the metal hanger rod and rubber isolator helps removal.)**

4. Raise hitch into position over exhaust and install supplied and existing fasteners as shown.

5. Torque all 8mm fasteners to 23 lb-ft, all 3/8" fasteners to 45 lb-ft, and all 5/8" fasteners to 210 lb-ft.

6. Re-install rubber isolators and exhaust removed in step 2.

**PERIODICALLY CHECK THIS RECEIVER HITCH TO ENSURE THAT ALL FASTENERS ARE TIGHT AND THAT ALL STRUCTURAL COMPONENTS ARE SOUND.**

Curt Manufacturing LLC., warrants this product to be free of defects in material and/or workmanship at the time of retail purchase by the original purchaser. If the product is found to be defective, Curt Manufacturing LLC., may repair or replace the product, at their option, when the product is returned, prepaid, with proof of purchase. Alteration to, misuse of, or improper installation of this product voids the warranty. Curt Manufacturing LLC.'s liability is limited to repair or replacement of products found to be defective, and specifically excludes liability for incidental or consequential loss or damage.