

12186**2001-2002 CHRYSLER SEBRING 4 DR.**

10/19/2012

GROSS LOAD CAPACITY WHEN USED AS A WEIGHT CARRYING HITCH: 3,500 LBS. TRAILER WEIGHT & 350 LBS. TONGUE WEIGHT.

*****DO NOT EXCEED VEHICLE MANUFACTURER'S RECOMMENDED TOWING CAPACITY.*******WARNING: ALL NON-TRAILER LOADS APPLIED TO THIS PRODUCT MUST BE SUPPORTED BY AUXILIARY STABILIZING STRAPS.****** FAILURE TO PROPERLY SUPPORT NON-TRAILER LOADS WILL VOID PRODUCT WARRANTY****

HAVING INSTALLATION QUESTIONS? CALL TECHNICAL SUPPORT AT 1-800-798-0813

Parts List				
ITEM	QTY	PART NUMBER	DESCRIPTION	
1	2	1/2-13	HANDLE NUT	
2	1	CM-438-FW	7/16" FISHWIRE TOOL	
3	2	1/2"	CONICAL TOOTHED WASHER	
4	2	CM-SP2	.250 x .88 x 2.25" SQUARE HOLE SPACER	
5	2	7/16-14	HEX FLANGE NUT	
6	3	M10 - 1.5 x 35mm	HEX TAP BOLT	
7	3	3/8"	CONICAL TOOTHED WASHER	
8	2	CM-SP12	.250 x 1.00 x 2.00" SQUARE HOLE SPACER	
9	2	3/8-16 x 3	HEX BOLT	
10	22	3/8"	WASHER	
11	4	3/8 - 16	HEX NUT	
12	2	1/2-13 x 1 1/4	HEX BOLT	
13	2	7/16-14 x 1 1/2	CARRIAGE BOLT	

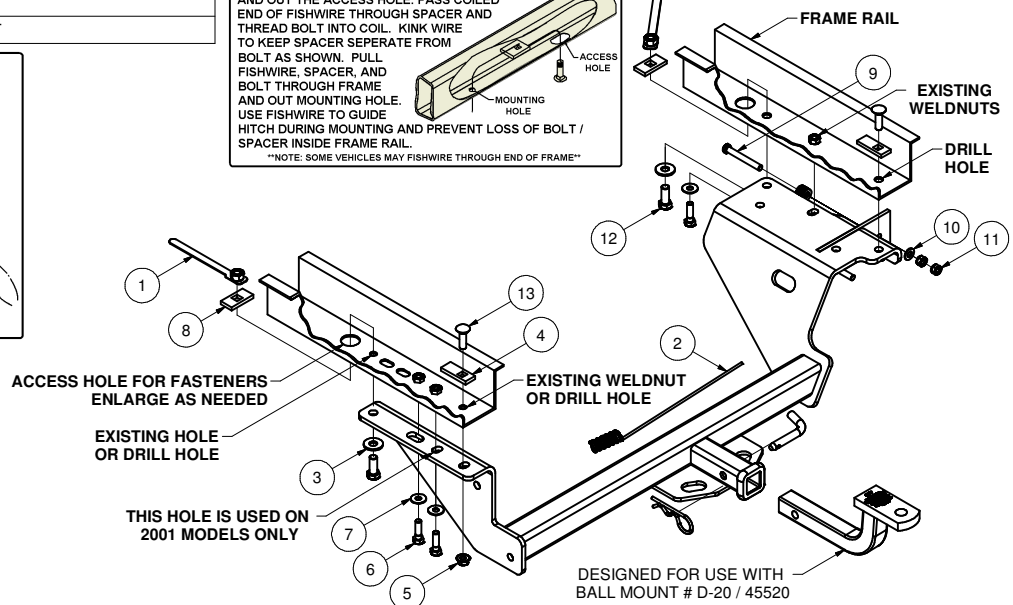
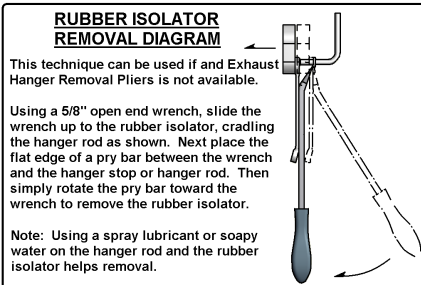
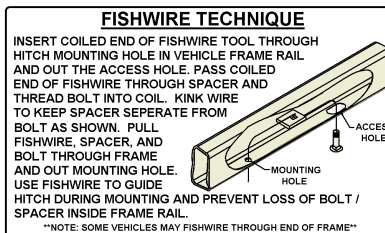
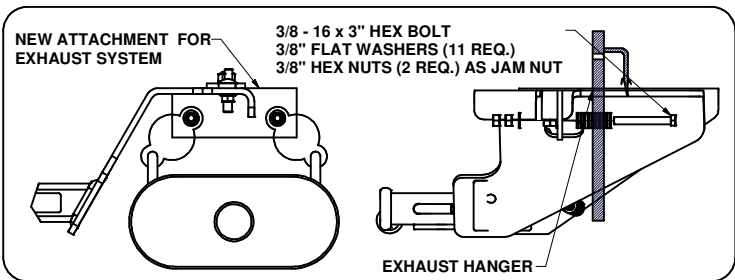

HITCH WEIGHT: .37 LBS.

INSTALL TIME

PROFESSIONAL: .40 MINUTES

NOVICE (DIY): .85 MINUTES

INSTALL NOTES:

- LOWER EXHAUST
- REMOVE EXHAUST BRACKET
- DRILING REQUIRED

INSTALLATION STEPS

- 1) Remove tie-down hook on driver's side frame rail. (Note: Reinstall two of the fasteners in the side of the frame.)
- 2) Lower exhaust system by removing two 8mm bolts and disconnecting the exhaust hanger bracket from the frame rail. Detach the rubber exhaust hanger from exhaust hanger bracket. Disconnect the rubber exhaust hanger forward of the muffler. (See RUBBER ISOLATOR REMOVAL)
- 3) Remove the 10mm bumper bracket bolt on the bottom of the passenger side frame rail.
- 4) Raise hitch into position and loosely install the three 10 mm bolts provided into existing weldnuts.
- 5) **On Pre-2002 Models:** Using the hitch as a template drill 1/2" holes in the frame rail at the forward attachment points on each side and at the rear attachment on the passenger side. **On 2002 and Later Models:** Using the hitch as a template drill 1/2" holes in the frame rail at the rearward attachment points on each side. Forward attachments holes are existing.
- 6) Install 7/16" fasteners as shown using the fishwire tool. (See FISHWIRE TECHNIQUE)
- 7) Using access hole in frame install handle nut assembly as shown above. Install 1/2" fasteners as shown.
- 8) Raise exhaust system into position, and install 3/8-16 x 3" bolt and fasteners. Jam nuts together to prevent from loosening. Reattach forward rubber exhaust hanger.
- 9) Return tie-down hook, tie-down fasteners, exhaust hanger bracket, 10mm & 8mm fasteners to vehicle owner, for reattachment if hitch is ever removed.
- 10) Torque 1/2" fasteners to 110 lb.-ft. Torque 7/16" fasteners to 70 lb.-ft. Torque 10mm fasteners to 45 lb.-ft. Torque 3/8" fasteners to 45 lb.-ft.

PERIODICALLY CHECK THIS RECEIVER HITCH TO ENSURE THAT ALL FASTENERS ARE TIGHT AND THAT ALL STRUCTURAL COMPONENTS ARE SOUND.

Curt Manufacturing Inc., warrants this product to be free of defects in material and/or workmanship at the time of retail purchase by the original purchaser. If the product is found to be defective, Curt Manufacturing Inc., may repair or replace the product, at their option, when the product is returned, prepaid, with proof of purchase. Alteration to, misuse of, or improper installation of this product voids the warranty. Curt Manufacturing Inc.'s liability is limited to repair or replacement of products found to be defective, and specifically excludes liability for incidental or consequential loss or damage.