

**13017****73-91 CHEVY / GMC SUBURBAN**

10/15/2012

GROSS LOAD CAPACITY WHEN USED AS A WEIGHT CARRYING HITCH: 6,000 LBS. TRAILER WEIGHT & 600 LBS. TONGUE WEIGHT.  
 GROSS LOAD CAPACITY WHEN USED AS A WEIGHT DISTRIBUTION HITCH: 10,000 LBS. TRAILER WEIGHT & 1,000 LBS. TONGUE WEIGHT

**\*\*\*DO NOT EXCEED VEHICLE MANUFACTURER'S RECOMMENDED TOWING CAPACITY.\*\*\***

Parts List			
ITEM	QTY	PART NUMBER	DESCRIPTION
1	4	CM-SP1	.250 x 1.50 x 2.00" SQUARE HOLE SPACER
2	4	HFN 1213	HEX FLANGE NUT
3	4	1/2-13 x 1 3/4	CARRIAGE BOLT

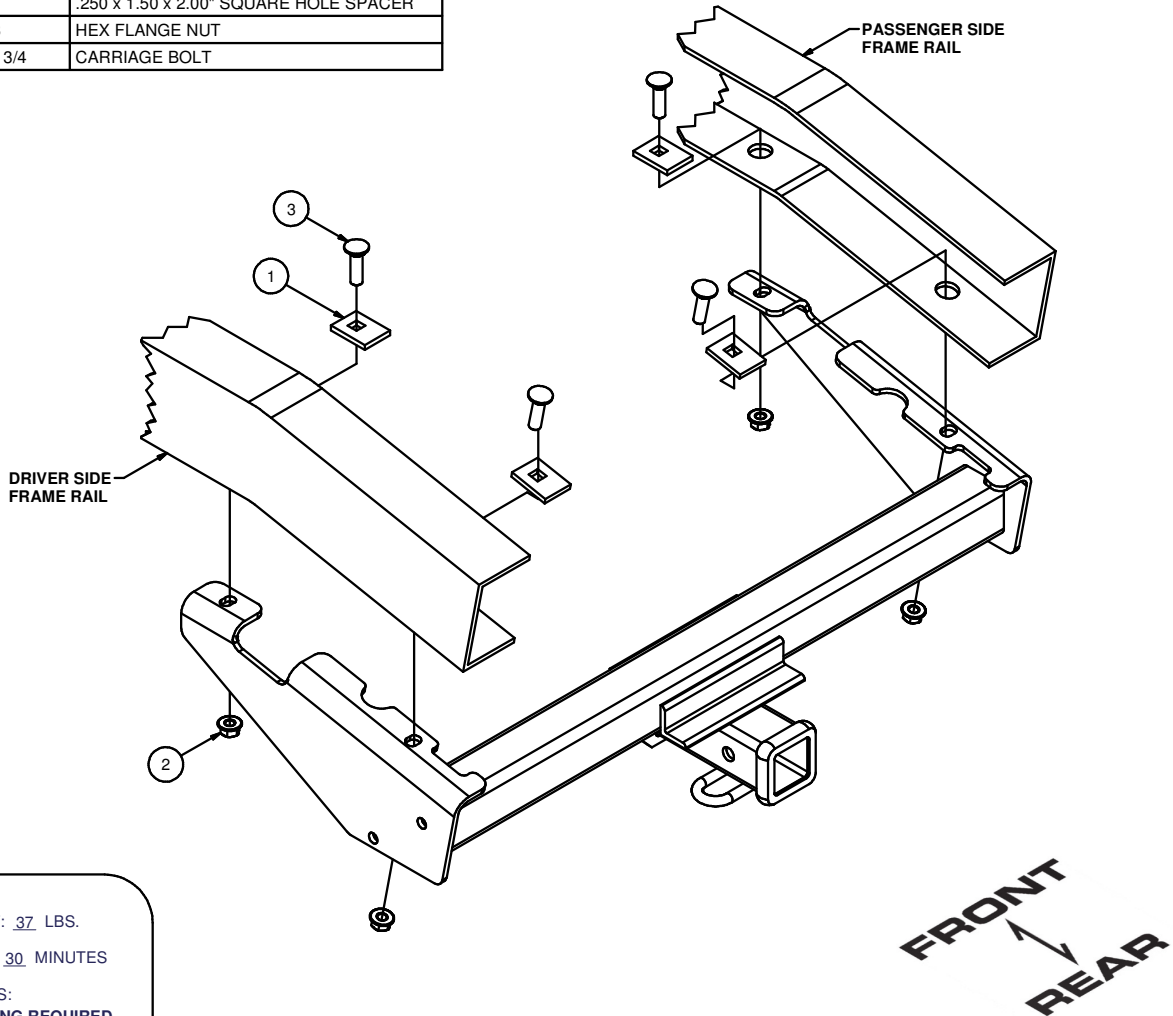
HITCH WEIGHT: 37 LBS.INSTALL TIME: 30 MINUTES

INSTALL NOTES:

- SOME DRILLING REQUIRED
- ON EARLIER MODELS

**INSTALLATION STEPS**

**NOTE: WIRING HARNESS MAY BE LOCATED WITHIN THE VEHICLE'S FRAME. REPOSITION THE HARNESS PRIOR TO DRILLING HOLES NECESSARY.**

1) Position the receiver as shown, lining up with all the existing holes in the frame.

**NOTE:** It may be necessary to deflect side brackets slightly to line up all existing holes in the frame near the fuel tank.

**NOTE:** It may be necessary to drill holes in the frame on early models.

2) Install all fasteners as shown.

3) Torque all fasteners to 110 lb.-ft.

**PERIODICALLY CHECK THIS RECEIVER HITCH TO ENSURE THAT ALL FASTENERS ARE TIGHT AND THAT ALL STRUCTURAL COMPONENTS ARE SOUND.**

Curt Manufacturing Inc., warrants this product to be free of defects in material and/or workmanship at the time of retail purchase by the original purchaser. If the product is found to be defective, Curt Manufacturing Inc., may repair or replace the product, at their option, when the product is returned, prepaid, with proof of purchase. Alteration to, misuse of, or improper installation of this product voids the warranty. Curt Manufacturing Inc.'s liability is limited to repair or replacement of products found to be defective, and specifically excludes liability for incidental or consequential loss or damage.