

13125

97-03 FORD EXPEDITION & 98-03 LINCOLN NAVIGATOR

10/19/2012

GROSS LOAD CAPACITY WHEN USED AS A WEIGHT CARRYING HITCH: 5,000 LBS. TRAILER WEIGHT & 500 LBS. TONGUE WEIGHT.
 GROSS LOAD CAPACITY WHEN USED AS A WEIGHT DISTRIBUTION HITCH: 7,500 LBS. TRAILER WEIGHT & 750 LBS. TONGUE WEIGHT

DO NOT EXCEED VEHICLE MANUFACTURER'S RECOMMENDED TOWING CAPACITY.

Parts List			
ITEM	QTY	PART NUMBER	DESCRIPTION
1	4	CM-SP20	.250 x 1.50 x 4.00" SQUARE HOLE SPACER
2	8	1/2 - 13 x 2"	CARRIAGE BOLT
3	8	HFN 1213	HEX FLANGE NUT

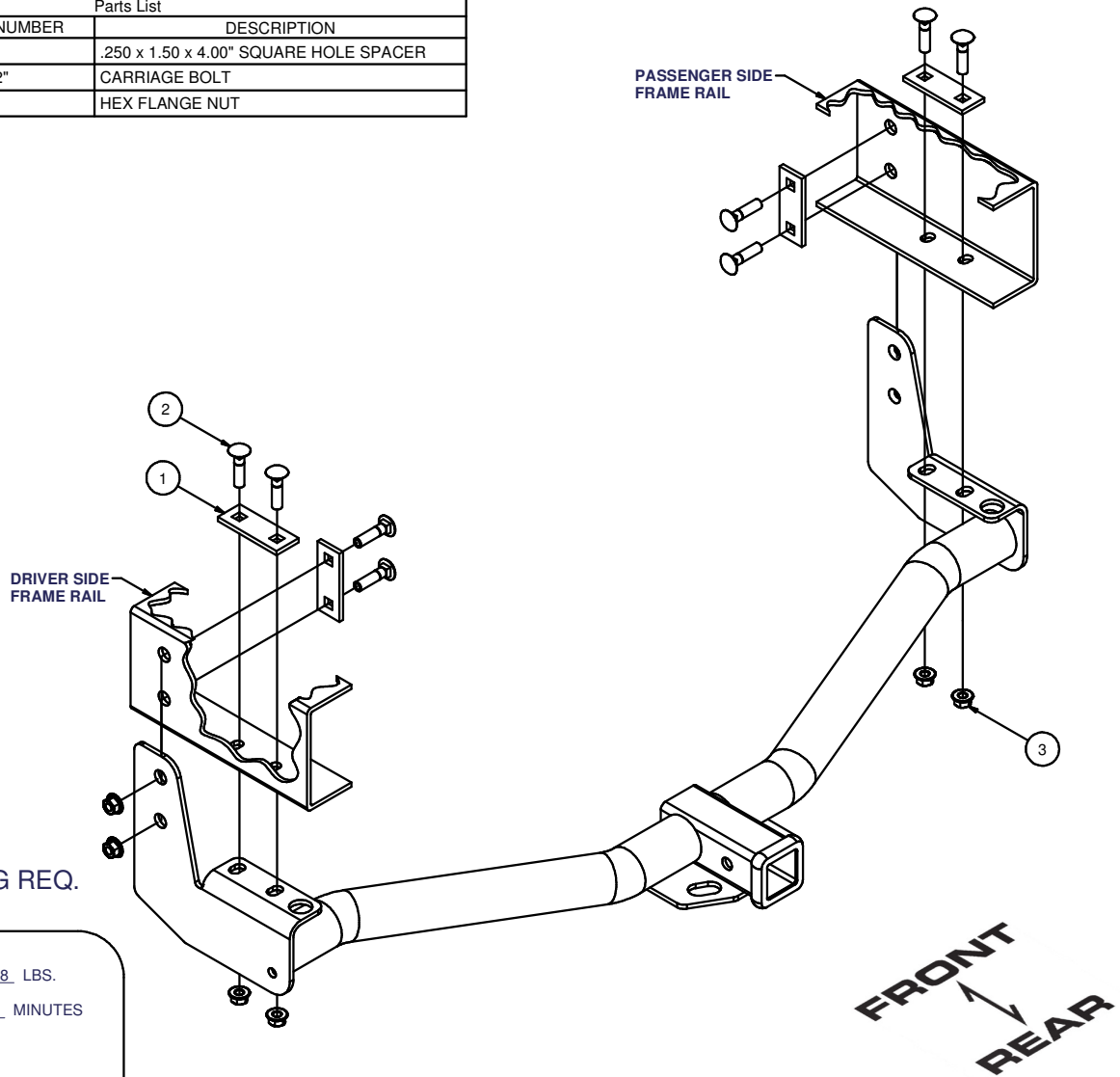

NO DRILLING REQ.

HITCH WEIGHT: 38 LBS.

INSTALL TIME: 10 MINUTES

INSTALL NOTES:

NO DRILLING REQUIRED

INSTALLATION STEPS

- 1) Raise hitch into position with the attachments in the vertical portion of the bracket on the outside of the frame.
- 2) Install the 1/2" carriage bolt and block into the rearmost attachment holes in each frame rail. Attach with the flange nut but do not tighten.
- 3) Insert the 1/2" carriage bolt and block into the forward attachment holes in each frame rail. Attach with flange nuts and tighten.
- 4) Torque all fasteners to 110 lb-ft.

PERIODICALLY CHECK THIS RECEIVER HITCH TO ENSURE THAT ALL FASTENERS ARE TIGHT AND THAT ALL STRUCTURAL COMPONENTS ARE SOUND.

Curt Manufacturing Inc., warrants this product to be free of defects in material and/or workmanship at the time of retail purchase by the original purchaser. If the product is found to be defective, Curt Manufacturing Inc., may repair or replace the product, at their option, when the product is returned, prepaid, with proof of purchase. Alteration to, misuse of, or improper installation of this product voids the warranty. Curt Manufacturing Inc.'s liability is limited to repair or replacement of products found to be defective, and specifically excludes liability for incidental or consequential loss or damage.