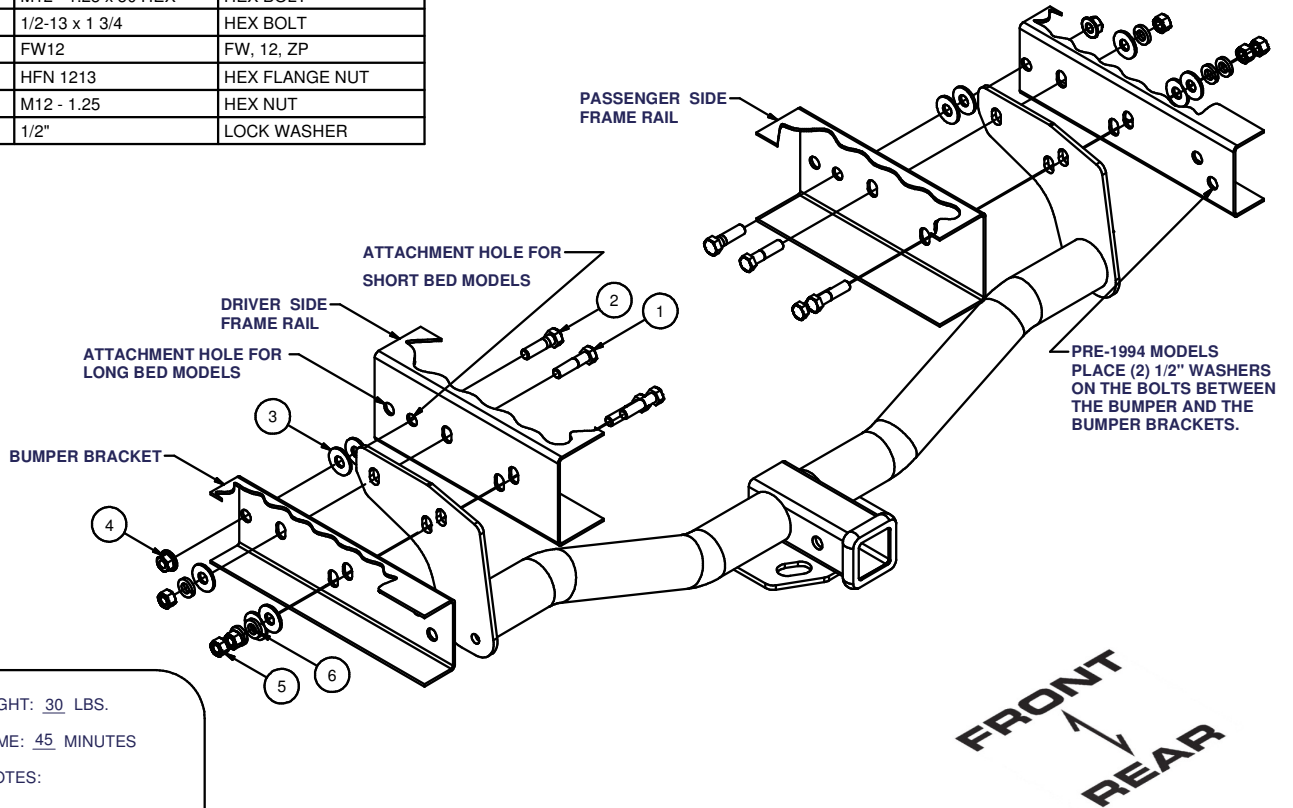

1313283-04 CHEVROLET S-10 PICKUP, GMC SONOMA PICKUP, GMC S-15 PICKUP,
96-00 ISUZU HOMBRE

9/24/2012

GROSS LOAD CAPACITY WHEN USED AS A WEIGHT CARRYING HITCH: 4,000 LBS. TRAILER WEIGHT & 400 LBS. TONGUE WEIGHT.
GROSS LOAD CAPACITY WHEN USED AS A WEIGHT DISTRIBUTION HITCH: 6,000 LBS. TRAILER WEIGHT & 600 LBS. TONGUE WEIGHT*****DO NOT EXCEED VEHICLE MANUFACTURER'S RECOMMENDED TOWING CAPACITY.*****

| Parts List | | | |
|------------|-----|---------------------|----------------|
| ITEM | QTY | PART NUMBER | DESCRIPTION |
| 1 | 6 | M12 - 1.25 x 50 HEX | HEX BOLT |
| 2 | 2 | 1/2-13 x 1 3/4 | HEX BOLT |
| 3 | 10 | FW12 | FW, 12, ZP |
| 4 | 2 | HFN 1213 | HEX FLANGE NUT |
| 5 | 6 | M12 - 1.25 | HEX NUT |
| 6 | 6 | 1/2" | LOCK WASHER |

HITCH WEIGHT: 30 LBS.INSTALL TIME: 45 MINUTES

INSTALL NOTES:

- NO DRILLING REQUIRED
- ADJUST/LOWER SPARE TIRE

INSTALLATION STEPS**SPORTSIDE BED MODELS**

NOTE: Some spare tires may need to be lowered or repositioned slightly for hitch installation.

- 1) Remove bumper bracket bolts and return to vehicle owner.
- 2) Position hitch on frame and install fasteners as shown above.

STEP BUMPER MODELS

- 1) Remove bumper, leaving brackets attached to frame. Disconnect bumper wiring before removing bumper. *1998-Present models, remove plastic step thread from the top of the bumper. The bumper is attached to each bumper bracket by (4) vertical bolts.*
- 2) Remove bumper bracket from frame, remove bumper wiring guides from bumper brackets. Note: steps 3 & 4 required for early model vehicles using a cradle storage system for spare tire.
- 3) Mark spare tire carrier 1/8" inboard of outboard edge of frame.
- 4) Lower spare tire and cut off carrier along marked line.
- 5) Position receiver on frame and loosely reinstall bumper brackets using (3) M12 bolts and fasteners per side. Receiver brackets are sandwiched between bumper brackets and frame.
- 6) Pre-1994 models, reinstall bumper on bumper brackets with original bolts, using (2) 1/2" washers at each bolt location as spacers between brackets and bumper. 1994-Present models, reinstall bumper on bumper brackets with original bolts. Slots in bumper bracket allow for adjustment.
- 7) Raise spare tire back to position and secure. Reconnect bumper wiring.
- 8) Torque all fasteners to 110 lb-ft.

PERIODICALLY CHECK THIS RECEIVER HITCH TO ENSURE THAT ALL FASTENERS ARE TIGHT AND THAT ALL STRUCTURAL COMPONENTS ARE SOUND.

Curt Manufacturing Inc., warrants this product to be free of defects in material and/or workmanship at the time of retail purchase by the original purchaser. If the product is found to be defective, Curt Manufacturing Inc., may repair or replace the product, at their option, when the product is returned, prepaid, with proof of purchase. Alteration to, misuse of, or improper installation of this product voids the warranty. Curt Manufacturing Inc.'s liability is limited to repair or replacement of products found to be defective, and specifically excludes liability for incidental or consequential loss or damage.