

YEARS: 2014-CURRENT

MAKE: MITSUBISHI

MODEL: OUTLANDER

STYLE: SUV

WARNING: NEVER EXCEED YOUR VEHICLE MANUFACTURER'S RECOMMENDED TOWING CAPACITY







WEIGHT CARRYING:
 TRAILER WEIGHT: 4,000 LBS.
 TONGUE WEIGHT: 600 LBS.

WEIGHT DISTRIBUTION:
 TRAILER WEIGHT: 4,000 LBS.
 TONGUE WEIGHT: 600 LBS.

PRO INSTALL TIME: 30 MIN.
NOVICE INSTALL TIME: 60 MIN.

IF YOU ARE HESITANT TO UNDERTAKE THIS TASK ON YOUR OWN, CONTACT AN AUTHORIZED CURT INSTALLER FOR ADDITIONAL ASSISTANCE.





INSTALLATION REQUIRES:

 RATCHET	 TORQUE WRENCH	 12mm 14mm 17mm 3/4" SOCKET
 SOCKET EXTENSION	 SCREW DRIVER	 SAFETY GLASSES

INSTALLATION TIPS:

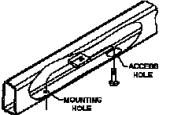
- BEFORE YOU BEGIN INSTALLATION, READ ALL INSTRUCTIONS THOROUGHLY.
- TO EASE INSTALLATION, 2 PEOPLE MAY BE REQUIRED.
- USING PROPER TOOLS WILL GREATLY IMPROVE THE QUALITY OF THE INSTALL AND REDUCE THE TIME REQUIRED.
- NEED HELP OR HAVE SOME QUESTIONS? CALL TECHNICAL SUPPORT AT 800.798.0813

LEVEL OF DIFFICULTY: MODERATE

EASY	MODERATE	CHALLENGING
	- NO DRILLING	
	- FISHWIRE HARDWARE	
	- REMOVE TOW LOOP	
	- LOWER EXHAUST	
	- CLEAN WELDNUTS	

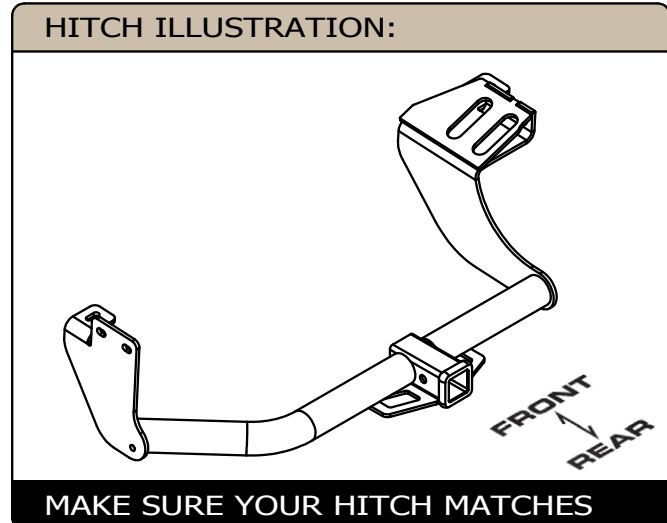
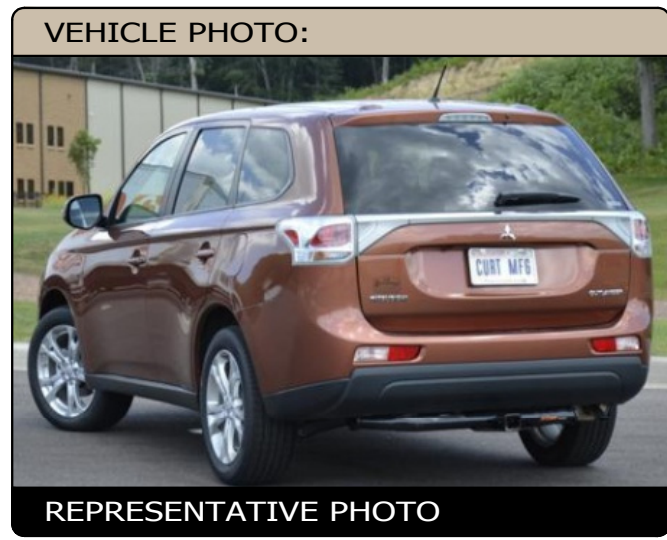

PERIODICALLY CHECK THIS RECEIVER HITCH TO ENSURE ALL FASTENERS ARE TIGHT AND ALL STRUCTURAL COMPONENTS ARE SOUND

CURT Manufacturing LLC. warrants this product to be free of defects in material and/or workmanship at the time of retail purchase by the original purchaser. If the product is found to be defective, Curt Manufacturing LLC. may repair or replace the product at their option, when the product is returned, prepaid, with proof of purchase. Alteration to, misuse of, or improper installation of this product voids the warranty. Curt Manufacturing LLC.'s liability is limited to repair or replacement of products found to be defective, and specifically excludes liability for incidental or consequential loss or damage.

For more information log onto www.curtmfg.com, & for helpful towing tips log onto www.hitchinfo.com

INSTALLATION WALKTHROUGH:

Parts List			
ITEM	QTY	PART NUMBER	DESCRIPTION
1	4	1/2-13 x 4 1/2	CARRIAGE BOLT
2	2	1_2 FISHWIRE	1/2" FISHWIRE
3	2	7/16"	CONICAL TOOTHED WASHER
4	4	HFN 1213	HEX FLANGE NUT
5	2	M10-1.25 x 35	HEX BOLT
6	2	13163-SP	.250" SPACER PLATE

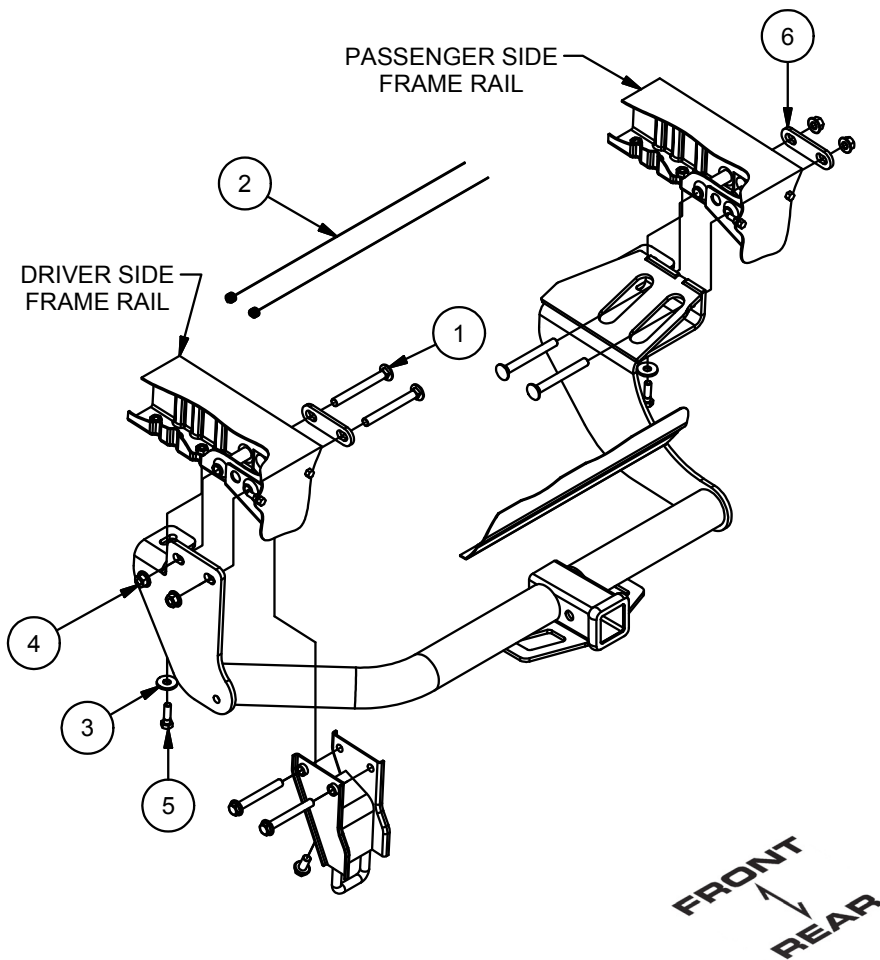

1. Remove (3) bolts and tow loop from the driver side frame rail. Return bolts and tow loop to owner.



2. Lower exhaust by removing (3) rubber isolators. Support exhaust as needed to prevent damage.

RUBBER ISOLATOR REMOVAL DIAGRAM

This technique can be used if an Exhaust Hanger Removal Pliers is not available.

Using a 5/8" open end wrench, slide the wrench up to the rubber isolator, cradling the hanger rod as shown. Next place the flat edge of a pry bar between the wrench and the hanger stop or hanger rod. Then simply rotate the pry bar toward the wrench to remove the rubber isolator.

Note: Using a spray lubricant or soapy water on the hanger rod and the rubber isolator helps removal.

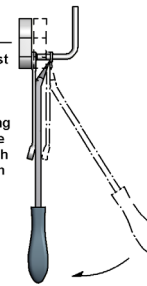

INSTALLATION WALKTHROUGH:

3. Raise the hitch into position and align the bottom tabs of the hitch with the center weldnuts in the frame rails. Loosely secure the hitch to the bottom of the frame rails with M10-1.25 x 35mm hex bolts and 7/16" conical toothed washers. **Note:** On the end of the passenger side frame rail you may need to back out the inner bumper bolt to allow the hitch to be fully raised.

EXISTING 8mm
BUMPER BOLT

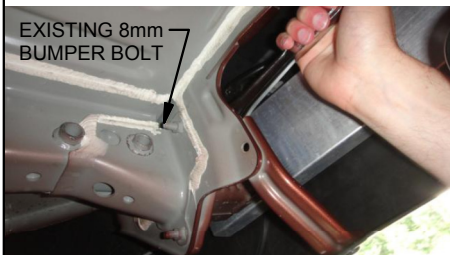

4. On the driver side, insert the 1/2-13 x 4-1/2" carriage bolts and 13163-SP spacer through the frame rail and out the driver side plate, secure using 1/2-13 flange nuts. **Note:** You may need to lower or pull down on the spare tire to allow the carriage bolts to slide through the frame rail.

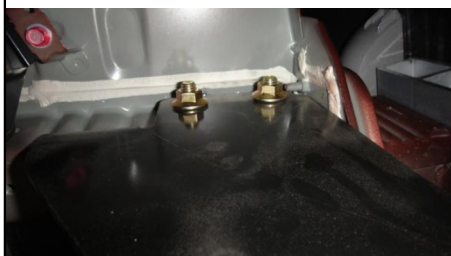

5. On the passenger side, fishwire the 1/2-13 x 4-1/2" carriage bolts through the passenger side plate and out the frame rail, secure using the 13163-SP spacer and 1/2-13 flange nuts. **Note:** If the inner bumper bolt was backed out in Step 3, tighten and torque to 25 ft-lbs.



6. Torque all 10mm hardware to 48 ft-lbs. Torque all 1/2" hardware to 110 ft-lbs. Raise exhaust back into position.



13163

MITSUBISHI OUTLANDER

8/02/2013

GROSS LOAD CAPACITY WHEN USED AS A WEIGHT CARRYING HITCH: 4,000 LBS. TRAILER WEIGHT & 600 LBS. TONGUE WEIGHT. GROSS LOAD CAPACITY WHEN USED AS A WEIGHT DISTRIBUTION HITCH: 4,000 LBS. TRAILER WEIGHT & 600 LBS. TONGUE WEIGHT

DO NOT EXCEED VEHICLE MANUFACTURER'S RECOMMENDED TOWING CAPACITY.

HAVING INSTALLATION QUESTIONS? CALL TECHNICAL SUPPORT AT 1-800-798-0813

Parts List			
ITEM	QTY	PART NUMBER	DESCRIPTION
1	4	1/2-13 x 4 1/2	CARRIAGE BOLT
2	2	1_2 FISHWIRE	1/2" FISHWIRE
3	2	7/16"	CONICAL TOOTHED WASHER
4	4	HFN 1213	HEX FLANGE NUT
5	2	M10-1.25 x 35	HEX BOLT
6	2	13163-SP	.250" SPACER PLATE

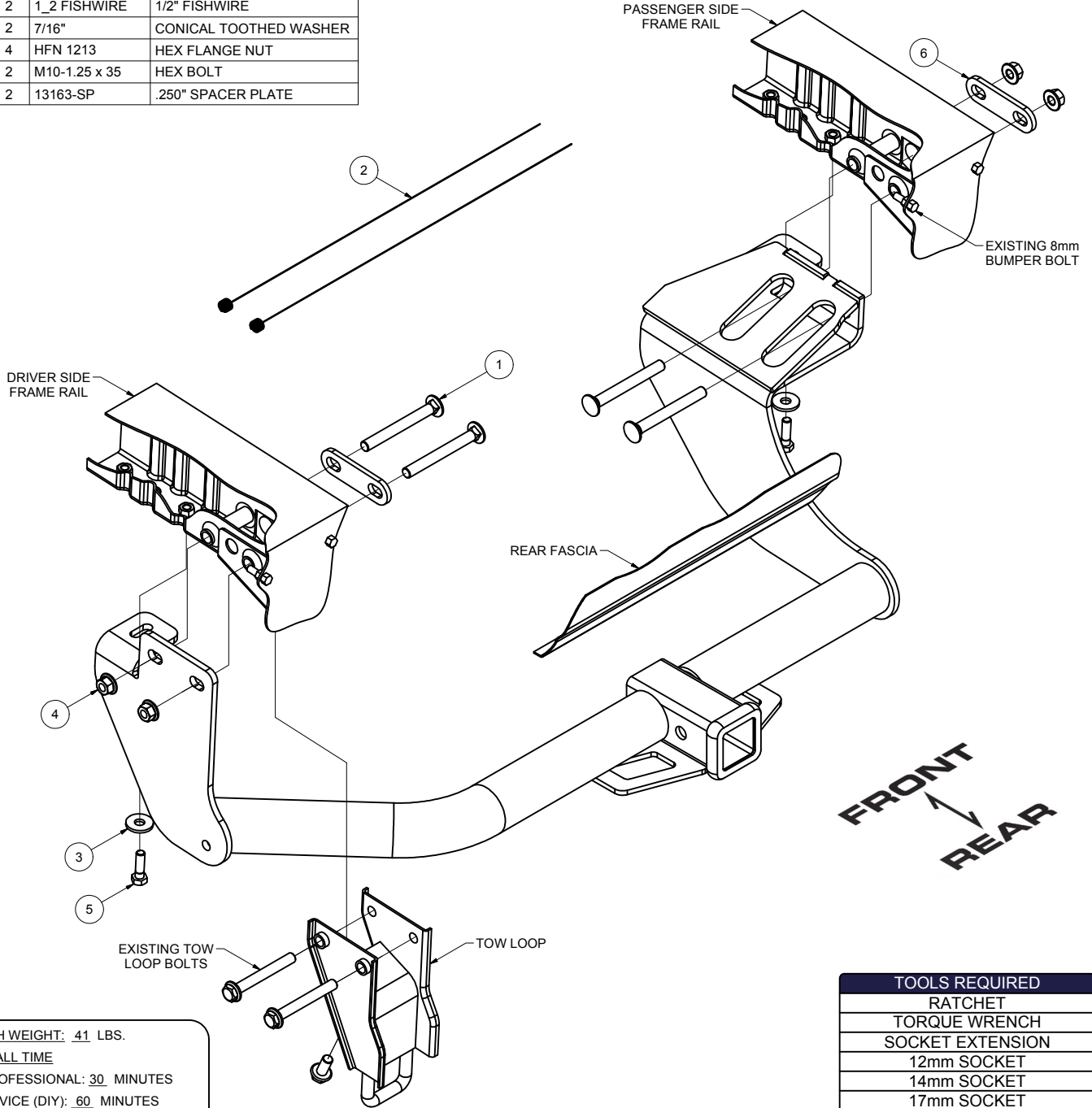

HITCH WEIGHT: 41 LBS.
 INSTALL TIME
 PROFESSIONAL: 30 MINUTES
 NOVICE (DIY): 60 MINUTES
 INSTALL NOTES:
 - NO DRILLING
 - FISHWIRE HARDWARE
 - REMOVE TOW LOOP

TOOLS REQUIRED
RATCHET
TORQUE WRENCH
SOCKET EXTENSION
12mm SOCKET
14mm SOCKET
17mm SOCKET
3/4" SOCKET
SCREWDRIVER
SAFETY GLASSES

PERIODICALLY CHECK THIS RECEIVER HITCH TO ENSURE THAT ALL FASTENERS ARE TIGHT AND THAT ALL STRUCTURAL COMPONENTS ARE SOUND.

Curt Manufacturing LLC., warrants this product to be free of defects in material and/or workmanship at the time of retail purchase by the original purchaser. If the product is found to be defective, Curt Manufacturing LLC., may repair or replace the product, at their option, when the product is returned, prepaid, with proof of purchase. Alteration to, misuse of, or improper installation of this product voids the warranty. Curt Manufacturing LLC.'s liability is limited to repair or replacement of products found to be defective, and specifically excludes liability for incidental or consequential loss or damage.

13163

MITSUBISHI OUTLANDER

GROSS LOAD CAPACITY WHEN USED AS A WEIGHT CARRYING HITCH: 4,000 LBS. TRAILER WEIGHT & 600 LBS. TONGUE WEIGHT.
GROSS LOAD CAPACITY WHEN USED AS A WEIGHT DISTRIBUTION HITCH: 4,000 LBS. TRAILER WEIGHT & 600 LBS. TONGUE WEIGHT

DO NOT EXCEED VEHICLE MANUFACTURER'S RECOMMENDED TOWING CAPACITY.

HAVING INSTALLATION QUESTIONS? CALL TECHNICAL SUPPORT AT 1-800-798-0813

RUBBER ISOLATOR REMOVAL DIAGRAM

This technique can be used if an Exhaust Hanger Removal Pliers is not available.

Using a 5/8" open end wrench, slide the wrench up to the rubber isolator, cradling the hanger rod as shown. Next place the flat edge of a pry bar between the wrench and the hanger stop or hanger rod. Then simply rotate the pry bar toward the wrench to remove the rubber isolator.

Note: Using a spray lubricant or soapy water on the hanger rod and the rubber isolator helps removal.

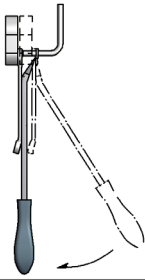

FISHWIRE TECHNIQUE

INSERT COILED END OF FISHWIRE TOOL THROUGH HITCH MOUNTING HOLE IN VEHICLE FRAME RAIL AND OUT THE ACCESS HOLE. PASS COILED END OF FISHWIRE THROUGH SPACER AND THREAD BOLT INTO COIL. KINK WIRE TO KEEP SPACER SEPARATE FROM BOLT AS SHOWN. PULL FISHWIRE, SPACER, AND BOLT THROUGH FRAME AND OUT MOUNTING HOLE. USE FISHWIRE TO GUIDE HITCH DURING MOUNTING AND PREVENT LOSS OF BOLT / SPACER INSIDE FRAME RAIL.

NOTE: SOME VEHICLES MAY FISHWIRE THROUGH END OF FRAME

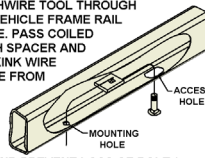

WELDNUT CLEANING

To remove debris from weldnuts in frame, spray lubricant or compressed air into hole. For heavy debris, use a small wire brush. (Be careful not to damage threads.)

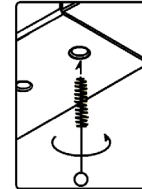

CONICAL TOOTHED WASHER ORIENTATION DIAGRAM

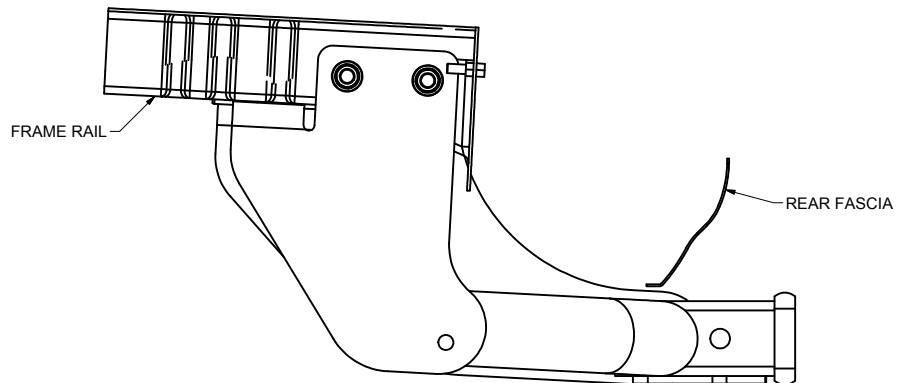
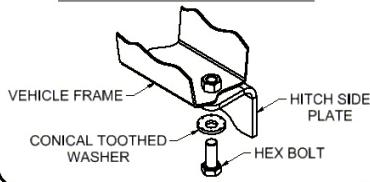

HITCH SHOWN IN PROPER POSITION

INSTALLATION STEPS

1. Remove (3) bolts and tow loop from the driver side frame rail. Return bolts and tow loop to owner.
2. Lower exhaust by removing (3) rubber isolators. Support exhaust as needed to prevent damage.
3. Raise the hitch into position and align the bottom tabs of the hitch with the center weldnuts in the frame rails. Loosely secure the hitch to the bottom of the frame rails with M10-1.25 x 35mm hex bolts and 7/16" conical toothed washers. **Note:** On the end of the passenger side frame rail you may need to back out the inner bumper bolt to allow the hitch to be fully raised.
4. On the driver side, insert the 1/2-13 x 4-1/2" carriage bolts and 13163-SP spacer through the frame rail and out the driver side plate, secure using 1/2-13 flange nuts. **Note:** You may need to lower or pull down on the spare tire to allow the carriage bolts to slide through the frame rail.
5. On the passenger side, fishwire the 1/2-13 x 4-1/2" carriage bolts through the passenger side plate and out the frame rail, secure using the 13163-SP spacer and 1/2-13 flange nuts. **Note:** If the inner bumper bolt was backed out in Step 3, tighten and torque to 25 ft-lbs.
6. Torque all 10mm hardware to 48 ft-lbs.
Torque all 1/2" hardware to 110 ft-lbs.
7. Raise exhaust back into position.

PERIODICALLY CHECK THIS RECEIVER HITCH TO ENSURE THAT ALL FASTENERS ARE TIGHT AND THAT ALL STRUCTURAL COMPONENTS ARE SOUND.

Curt Manufacturing LLC., warrants this product to be free of defects in material and/or workmanship at the time of retail purchase by the original purchaser. If the product is found to be defective, Curt Manufacturing LLC., may repair or replace the product, at their option, when the product is returned, prepaid, with proof of purchase. Alteration to, misuse of, or improper installation of this product voids the warranty. Curt Manufacturing LLC.'s liability is limited to repair or replacement of products found to be defective, and specifically excludes liability for incidental or consequential loss or damage.