

YEARS: 2014

MAKE: MERCEDES-BENZ

MODEL: GL350,450,550

INCLUDES BlueTEC,
EXCLUDES Active Curve Sys

STYLE: SUV

WARNING: NEVER EXCEED YOUR VEHICLE MANUFACTURER'S RECOMMENDED TOWING CAPACITY

WEIGHT CARRYING:
 TRAILER WEIGHT: 7,500 LBS.
 TONGUE WEIGHT: 900 LBS.

WEIGHT DISTRIBUTION:
 TRAILER WEIGHT: N/A LBS.
 TONGUE WEIGHT: N/A LBS.

PRO INSTALL TIME: 40 MIN.
NOVICE INSTALL TIME: 80 MIN.

IF YOU ARE HESITANT TO UNDERTAKE THIS TASK ON YOUR OWN, CONTACT AN AUTHORIZED CURT INSTALLER FOR ADDITIONAL ASSISTANCE.

INSTALLATION TIPS:

- BEFORE YOU BEGIN INSTALLATION, READ ALL INSTRUCTIONS THOROUGHLY.
- TO EASE INSTALLATION, 2 PEOPLE MAY BE REQUIRED.
- USING PROPER TOOLS WILL GREATLY IMPROVE THE QUALITY OF THE INSTALL AND REDUCE THE TIME REQUIRED.
- NEED HELP OR HAVE SOME QUESTIONS? CALL TECHNICAL SUPPORT AT 800.798.0813



INSTALLATION REQUIRES:

SAFETY GLASSES	RATCHET	TORQUE WRENCH
6" SOCKET EXTENSION	8mm 10mm 13mm 3/4" SOCKET	ROTARY TOOL
SPRAY LUBRICANT		

LEVEL OF DIFFICULTY: MODERATE

EASY	MODERATE	CHALLENGING
	- NO DRILLING REQUIRED	
	- LOWER EXHAUST	
	- TRIM HEAT SHIELD	
	- TEMPORARY PART REMOVAL	

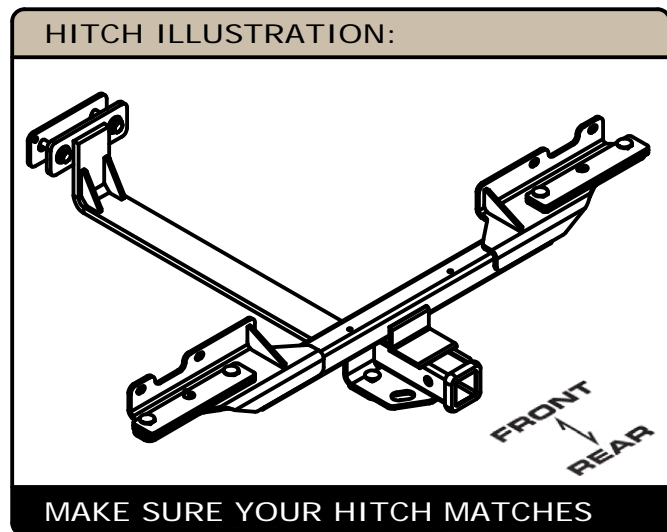

PERIODICALLY CHECK THIS RECEIVER HITCH TO ENSURE ALL FASTENERS ARE TIGHT AND ALL STRUCTURAL COMPONENTS ARE SOUND

CURT Manufacturing LLC. warrants this product to be free of defects in material and/or workmanship at the time of retail purchase by the original purchaser. If the product is found to be defective, Curt Manufacturing LLC. may repair or replace the product at their option, when the product is returned, prepaid, with proof of purchase. Alteration to, misuse of, or improper installation of this product voids the warranty. Curt Manufacturing LLC.'s liability is limited to repair or replacement of products found to be defective, and specifically excludes liability for incidental or consequential loss or damage.

For more information log onto www.curtmfg.com, & for helpful towing tips log onto www.hitchinfo.com

INSTALLATION WALKTHROUGH:

Parts List			
ITEM	QTY	PART NUMBER	DESCRIPTION
1	2	1/2	CONICAL TOOTHED WASHER
2	2	1/2-13 x 1	CARRIAGE BOLT
3	4	1/2-13 x 1 1/2	CARRIAGE BOLT
4	2	1/2-13 x 3	HEX BOLT
5	2	11120497	.344" X .813" BLACK NYLON TRIM PANEL RETAINER
6	2	3/8"	CONICAL TOOTHED WASHER
7	6	HFN 1213	HEX FLANGE NUT
8	2	M8 - 1.25 x 30 HEX BOLT	HEX HEAD BOLT
9	1	M8-1.25 x 40	HEX BOLT

Parts List			
ITEM	QTY	PART NUMBER	DESCRIPTION
A	1	13173-WA	HITCH WELDMENT ASSEMBLY
B	1	13173-MSWA	MOUNTING STRAP WELDMENT ASSEMBLY
C	1	13173-NPA	NUT PLATE ASSEMBLY
D	2	13173-BP	.250" BOLT PLATE
E	2	13173-SP	.250" SPACER PLATE

CONICAL TOOTHED WASHER ORIENTATION DIAGRAM

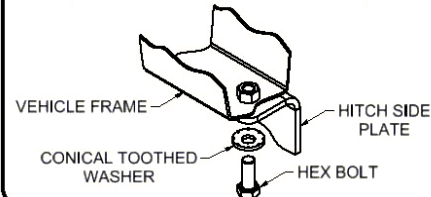

RUBBER ISOLATOR REMOVAL DIAGRAM

This technique can be used if an Exhaust Hanger Removal Pliers is not available.

Using a 5/8" open end wrench, slide the wrench up to the rubber isolator, cradling the hanger rod as shown. Next place the flat edge of a pry bar between the wrench and the hanger stop or hanger rod. Then simply rotate the pry bar toward the wrench to remove the rubber isolator.

Note: Using a spray lubricant or soapy water on the hanger rod and the rubber isolator helps removal.

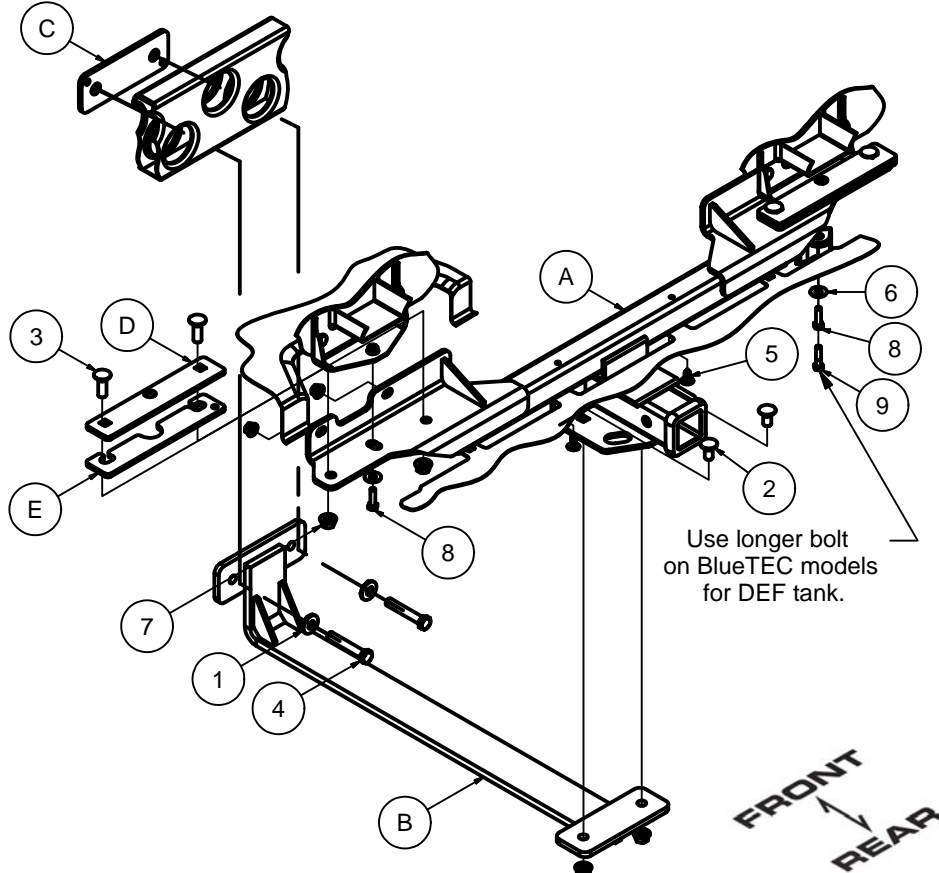
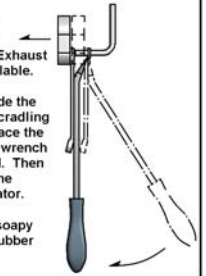

1. Locate and remove DEF tank shield by removing (6) plastic flange nuts and (1) screw with a 10mm socket. (BlueTEC vehicles only)

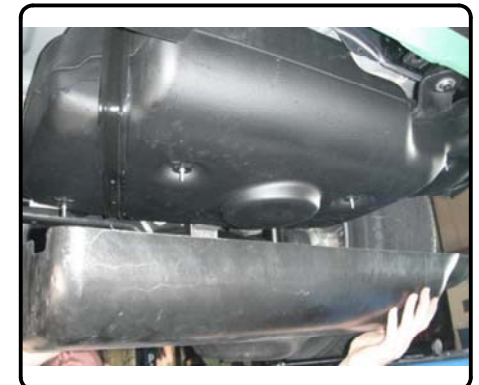
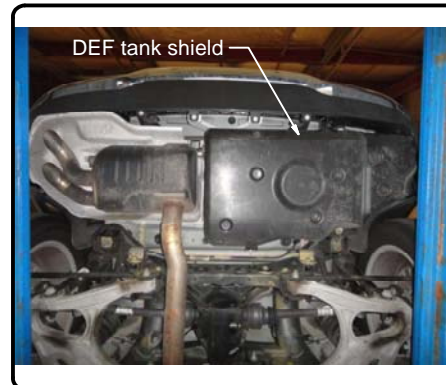

INSTALLATION WALKTHROUGH:

2. Remove the bumper fascia tabs by removing (3) bolts using a 10mm socket to remove center support bracket.

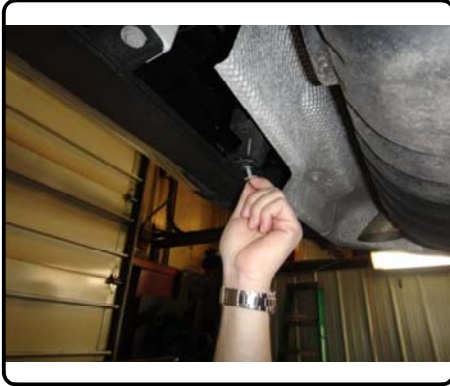

3. Lower the driver side exhaust by removing the rubber isolator from the hanger attached to the vehicle and unbolting the exhaust hanger bracket near the middle of the vehicle using a 13mm socket and ratchet. Repeat on passenger side if present. Support exhaust to prevent damage.



4. Remove the driver side heat shield by removing the (3) formed nuts and (1) bolt with an 8mm socket. Repeat on passenger side if present.



5. BlueTEC vehicles only, temporarily remove (2) bolts holding DEF tank and the (2) nuts securing the strap with an 8mm socket. Support DEF tank to prevent damage.



INSTALLATION WALKTHROUGH:

6. Remove the lower (2) nuts securing the bumper beam to the vehicle with a 10mm socket, both sides. Save for reassembly.



7. Trim and reinstall heat shield(s). (See Trim Diagram)
Note: Dimensions are approximate, confirm fit prior to trimming. Use rib in panel as a cutting guide.

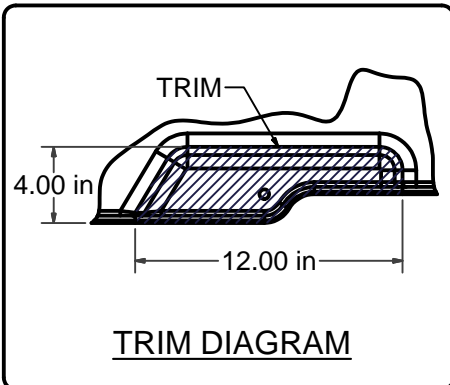

8. Raise hitch (A) into position and secure to the bumper beam studs using the vehicle nuts removed in Step (6).

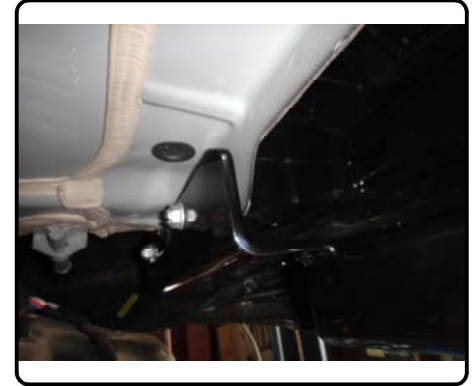

9. Stack bolt plate (D) on spacer plate (E) and run 1/2-13 x 1 1/2" carriage bolts through plate holes. Place plate assembly over the bumper beam tab and align with the holes in the hitch. Secure using 1/2-13 flange nuts, as shown.

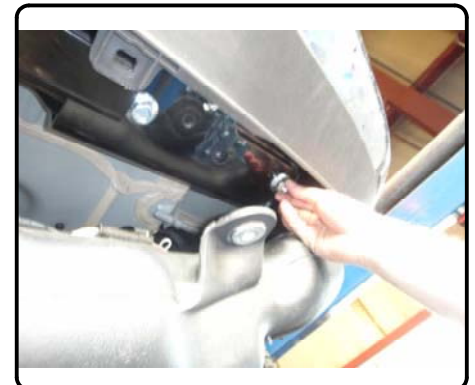

INSTALLATION WALKTHROUGH:

10. Center the holes of the hitch with the bumper beam tab weldnuts. Torque all M10 fasteners to 48 ft-lbs. Torque all installed 1/2" fasteners to 110 ft-lbs.



11. BlueTEC vehicles only, raise DEF tank and secure the mounting strap using hardware removed in Step (5). Secure DEF tank mounting tab using M8-1.25 x 40mm hex bolt and 3/8" conical toothed washer. Secure driver side using M8-1.25 x 30mm hex bolt and 3/8" conical toothed washer. Torque M8 hardware to 23 ft-lbs.



12. Raise and secure the exhaust lowered in Step (3). BlueTEC vehicles only, reinstall DEF tank shield removed in Step (1).

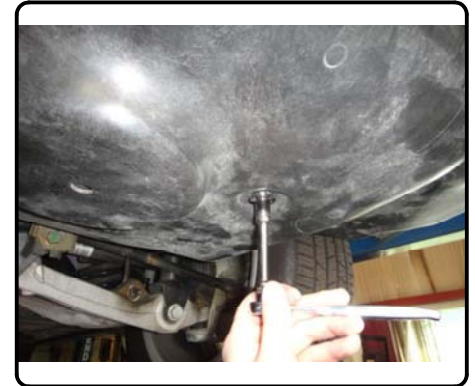

13. Raise mounting strap (B) into position and loosely secure to hitch 1/2-13 x 1" carriage bolts and 1/2-13 hex flange nuts. Raise nut plate (C) into position and secure mounting strap to the cross member using 1/2-13 x 3" hex bolts and 1/2" conical toothed washers.

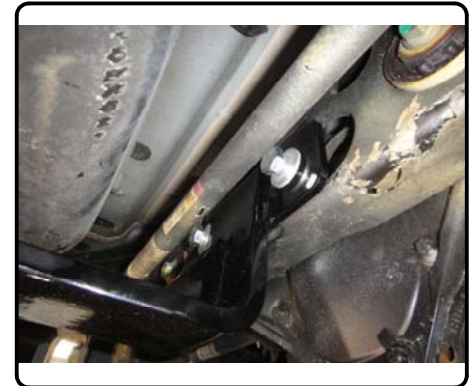
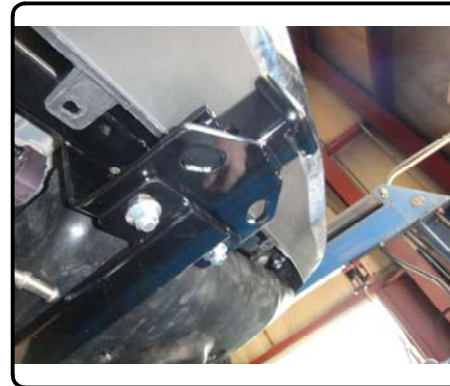

INSTALLATION WALKTHROUGH:

14. Torque all remaining 1/2" hardware to 110 ft-lbs.

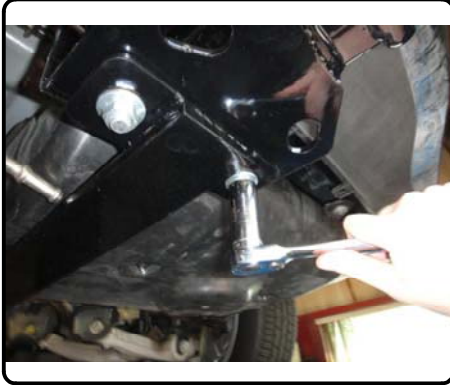

15. Secure the (2) center fascia tabs by pushing the nylon retainer clips into the holes in hitch tube.



INSTALLATION COMPLETE



13173 MERCEDES-BENZ GL350, GL450, GL550 Including BlueTEC, Excluding Active Curve System

2/4/2014

GROSS LOAD CAPACITY WHEN USED AS A WEIGHT CARRYING HITCH: 7,500 LBS. TRAILER WEIGHT & 900 LBS. TONGUE WEIGHT.
 GROSS LOAD CAPACITY WHEN USED AS A WEIGHT DISTRIBUTION HITCH: N/A LBS. TRAILER WEIGHT & N/A LBS. TONGUE WEIGHT

DO NOT EXCEED VEHICLE MANUFACTURER'S RECOMMENDED TOWING CAPACITY.

HAVING INSTALLATION QUESTIONS? CALL TECHNICAL SUPPORT AT 1-800-798-0813

Hardware List			
ITEM	QTY	PART NUMBER	DESCRIPTION
1	2	1/2	CONICAL TOOTHED WASHER
2	2	1/2-13 x 1	CARRIAGE BOLT
3	4	1/2-13 x 1 1/2	CARRIAGE BOLT
4	2	1/2-13 x 3	HEX BOLT
5	2	11120497	.344" X .813" BLACK NYLON TRIM PANEL RETAINER
6	2	3/8"	CONICAL TOOTHED WASHER
7	6	HFN 1213	HEX FLANGE NUT
8	2	M8 - 1.25 x 30 HEX BOLT	HEX HEAD BOLT
9	1	M8-1.25 x 40	HEX BOLT

Parts List			
ITEM	QTY	PART NUMBER	DESCRIPTION
A	1	13173-WA	HITCH WELDMENT ASSEMBLY
B	1	13173-MSWA	MOUNTING STRAP WELDMENT ASSEMBLY
C	1	13173-NPA	NUT PLATE ASSEMBLY
D	2	13173-BP	.250" BOLT PLATE
E	2	13173-SP	.250" SPACER PLATE

CONICAL TOOTHED WASHER ORIENTATION DIAGRAM

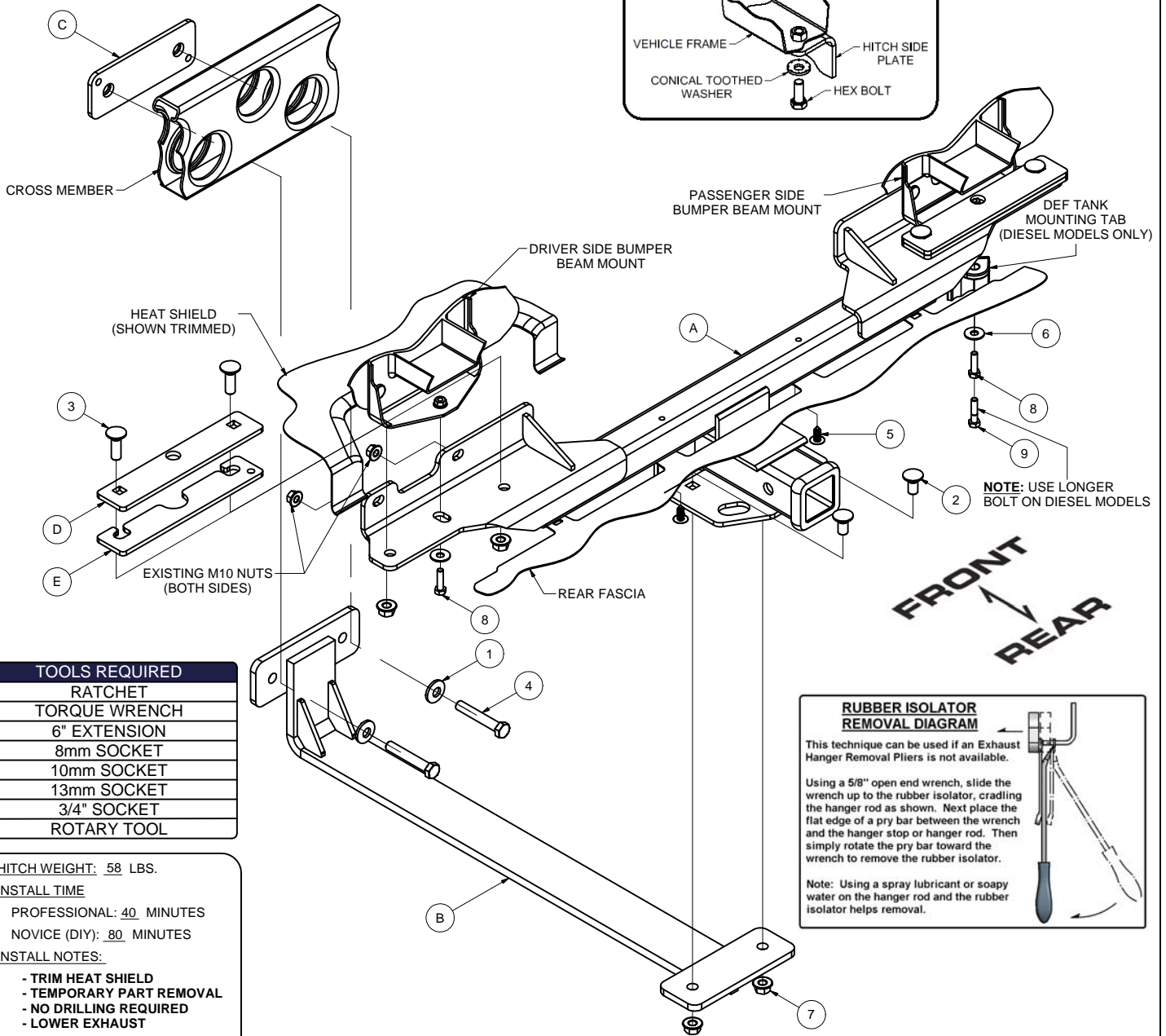
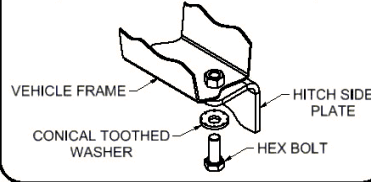

TOOLS REQUIRED
RATCHET
TORQUE WRENCH
6" EXTENSION
8mm SOCKET
10mm SOCKET
13mm SOCKET
3/4" SOCKET
ROTARY TOOL

HITCH WEIGHT: 58 LBS.
 INSTALL TIME
 PROFESSIONAL: 40 MINUTES
 NOVICE (DIY): 80 MINUTES
 INSTALL NOTES:
 - TRIM HEAT SHIELD
 - TEMPORARY PART REMOVAL
 - NO DRILLING REQUIRED
 - LOWER EXHAUST

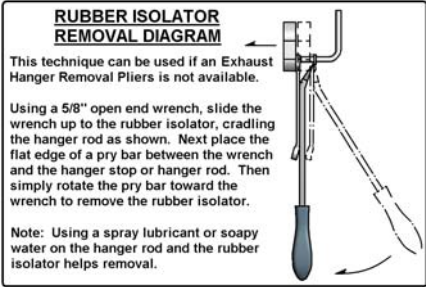

PERIODICALLY CHECK THIS RECEIVER HITCH TO ENSURE THAT ALL FASTENERS ARE TIGHT AND THAT ALL STRUCTURAL COMPONENTS ARE SOUND.



Curt Manufacturing LLC., warrants this product to be free of defects in material and/or workmanship at the time of retail purchase by the original purchaser. If the product is found to be defective, Curt Manufacturing LLC., may repair or replace the product, at their option, when the product is returned, prepaid, with proof of purchase. Alteration to, misuse of, or improper installation of this product voids the warranty. Curt Manufacturing LLC.'s liability is limited to repair or replacement of products found to be defective, and specifically excludes liability for incidental or consequential loss or damage.

13173 MERCEDES-BENZ GL350, GL450, GL550 Including BlueTEC, Excluding Active Curve System

GROSS LOAD CAPACITY WHEN USED AS A WEIGHT CARRYING HITCH: 7,500 LBS. TRAILER WEIGHT & 900 LBS. TONGUE WEIGHT.
GROSS LOAD CAPACITY WHEN USED AS A WEIGHT DISTRIBUTION HITCH: N/A LBS. TRAILER WEIGHT & N/A LBS. TONGUE WEIGHT

DO NOT EXCEED VEHICLE MANUFACTURER'S RECOMMENDED TOWING CAPACITY.

HAVING INSTALLATION QUESTIONS? CALL TECHNICAL SUPPORT AT 1-800-798-0813

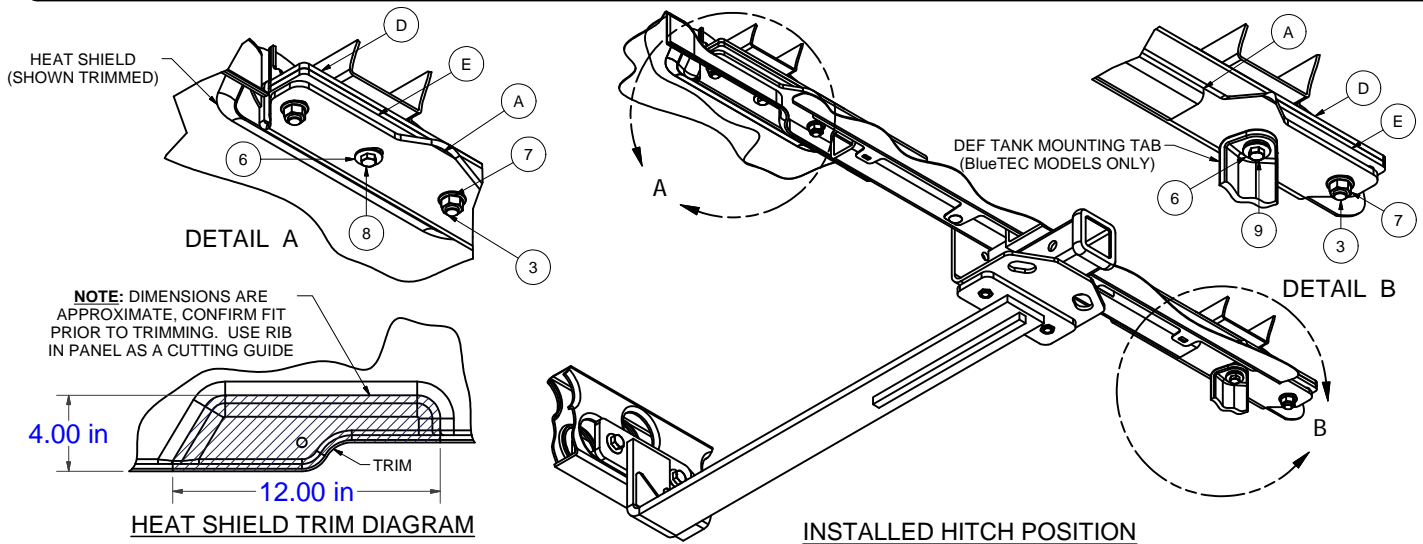

INSTALLATION STEPS

1. Locate and remove DEF tank shield by removing (6) plastic flange nuts and (1) screw with a 10mm socket. (BlueTEC vehicles only)
2. Remove the bumper fascia tabs by removing (3) bolts using a 10mm socket to remove center support.
3. Lower the driver side exhaust by removing the rubber isolator from the hanger attached to the vehicle and unbolting the exhaust hanger bracket near the middle of the vehicle using a 13mm socket. Repeat on passenger side if present. Support exhaust to prevent damage. (See Rubber Isolator Removal Diagram)
4. Remove the driver side heat shield by removing the (3) formed nuts and (1) bolt with an 8mm socket. Repeat on passenger side if present.
5. BlueTEC vehicles only, temporarily remove the (2) bolts holding DEF tank and the (2) nuts securing the strap with an 8mm socket. Support DEF tank to prevent damage.
6. Remove the lower (2) nuts securing the bumper beam to the vehicle with a 10mm socket, both sides.
7. Trim and reinstall heat shield(s). (See Trim Diagram) **Note:** Dimensions are approximate, confirm fit prior to trimming.
8. Raise hitch (A) into position and secure to the bumper beam studs using the vehicle nuts removed in Step (6).
9. Stack bolt plate (D) on spacer plate (E) and run 1/2-13 x 1 1/2" carriage bolts through plate holes. Place plate assembly over the bumper beam tab and align with the holes in the hitch. Secure using 1/2-13 flange nuts, as shown.
10. Center the holes of the hitch with the bumper beam tab weldnuts. Torque all M10 fasteners to 48 ft-lbs. Torque all installed 1/2" fasteners to 110 ft-lbs.
11. BlueTEC vehicles only, raise DEF tank and secure the mounting strap using hardware removed in Step (5). Secure DEF tank mounting tab using M8-1.25 x 40mm hex bolt and 3/8" conical toothed washer. Secure driver side using M8-1.25 x 30mm hex bolt and 3/8" conical toothed washer. Torque M8 hardware to 23 ft-lbs.
12. Raise and secure the exhaust lowered in Step (3).
13. BlueTEC vehicles only, reinstall DEF tank shield removed in Step (1).
14. Raise mounting strap (B) into position and loosely secure to hitch 1/2-13 x 1" carriage bolts and 1/2-13 hex flange nuts.
15. Raise nut plate (C) into position and secure mounting strap to the cross member using 1/2-13 x 3" hex bolts and 1/2" conical toothed washers.
16. Torque all remaining 1/2" hardware to 110 ft-lbs.
17. Secure the (2) center fascia tabs by pushing the nylon retainer clips into the holes in hitch tube.

PERIODICALLY CHECK THIS RECEIVER HITCH TO ENSURE THAT ALL FASTENERS ARE TIGHT AND THAT ALL STRUCTURAL COMPONENTS ARE SOUND.

Curt Manufacturing LLC., warrants this product to be free of defects in material and/or workmanship at the time of retail purchase by the original purchaser. If the product is found to be defective, Curt Manufacturing LLC., may repair or replace the product, at their option, when the product is returned, prepaid, with proof of purchase. Alteration to, misuse of, or improper installation of this product voids the warranty. Curt Manufacturing LLC.'s liability is limited to repair or replacement of products found to be defective, and specifically excludes liability for incidental or consequential loss or damage.