



Safety glasses should be worn at all times while installing this product.

YEARS: 2014-PRESENT

MAKE: RAM

MODEL: PROMASTER

STYLE: VAN

WARNING: NEVER EXCEED YOUR VEHICLE MANUFACTURER'S RECOMMENDED TOWING CAPACITY





WEIGHT CARRYING:
 TRAILER WEIGHT: 6,000 LBS.
 TONGUE WEIGHT: 750 LBS.

WEIGHT DISTRIBUTION:
 TRAILER WEIGHT: 7,500 LBS.
 TONGUE WEIGHT: 750 LBS.

PRO INSTALL TIME: 20 MIN.
NOVICE INSTALL TIME: 40 MIN.

IF YOU ARE HESITANT TO UNDERTAKE THIS TASK ON YOUR OWN, CONTACT AN AUTHORIZED CURT INSTALLER FOR ADDITIONAL ASSISTANCE.

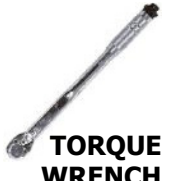
INSTALLATION REQUIRES:

| | | |
|--|---|--|
|  RATCHET |  SOCKET 3/4" 7/8" |  TORQUE WRENCH |
|  SCREW DRIVER | | |
| | | |
| | | |

INSTALLATION TIPS:

- BEFORE YOU BEGIN INSTALLATION, READ ALL INSTRUCTIONS THOROUGHLY.
- TO EASE INSTALLATION, 2 PEOPLE MAY BE REQUIRED.
- USING PROPER TOOLS WILL GREATLY IMPROVE THE QUALITY OF THE INSTALL AND REDUCE THE TIME REQUIRED.
- NEED HELP OR HAVE SOME QUESTIONS? CALL TECHNICAL SUPPORT AT 800.798.0813

LEVEL OF DIFFICULTY: EASY

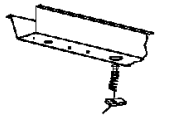
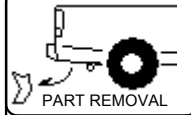
| EASY | MODERATE | CHALLENGING |
|---|---|-------------|
|  | NO DRILLING REQUIRED | |
|  | REVERSE FISHWIRE (2) FASTENERS | |
|  | REMOVE (2) RUBBER PLUGS FROM FRAME RAIL | |
| | | |
| | | |

VEHICLE PHOTO:



REPRESENTATIVE PHOTO

HITCH ILLUSTRATION:

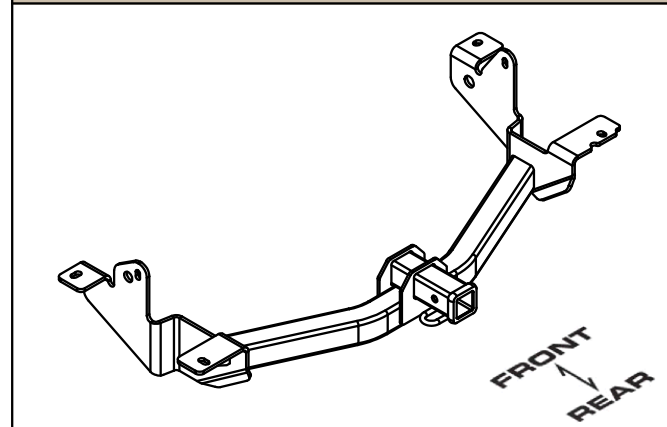

MAKE SURE YOUR HITCH MATCHES



PERIODICALLY CHECK THIS RECEIVER HITCH TO ENSURE ALL FASTENERS ARE TIGHT AND ALL STRUCTURAL COMPONENTS ARE SOUND
 CURT Manufacturing LLC. warrants this product to be free of defects in material and/or workmanship at the time of retail purchase by the original purchaser. If the product is found to be defective, CURT Manufacturing LLC. may repair or replace the product at their option, when the product is returned, prepaid, with proof of purchase. Alteration to, misuse of, or improper installation of this product voids the warranty. CURT Manufacturing LLC.'s liability is limited to repair or replacement of products found to be defective, and specifically excludes liability for incidental or consequential loss or damage. For more information log onto www.curtmfg.com, & for helpful towing tips log onto www.hitchinfo.com

INSTALLATION WALKTHROUGH:

| Parts List | | | |
|------------|-----|-----------------------------|--|
| ITEM | QTY | PART NUMBER | DESCRIPTION |
| 1 | 1 | 9_16-12 x 2.5 CARRIAGE BOLT | CARRIAGE BOLT |
| 2 | 1 | 9_16-12 x 2 CARRIAGE BOLT | CARRIAGE BOLT |
| 3 | 2 | CM-SP70 | .250 x 1.00 x 2.50" 9/16" SQUARE HOLE SPACER |
| 4 | 2 | 9_16-12 FLANGE NUT | HEX FLANGE NUT |
| 5 | 2 | 9_16 FISHWIRE | 9/16" FISHWIRE |
| 6 | 2 | 1/2-13 | HANDLE NUT |
| 7 | 2 | 1/2-13 x 5 1/2 | HEX BOLT |
| 8 | 2 | FW12 | FW, 12, ZP |
| 9 | 2 | 1_2 - 13 x 1 1_2 HEX, GR8 | HEX BOLT |
| 10 | 2 | 1/2 | CONICAL TOOTHED WASHER |
| 11 | 2 | HFN 1213, GR8 | HEX FLANGE NUT |
| 12 | 1 | 13207-SP | .625 x 2.00 SPACER |

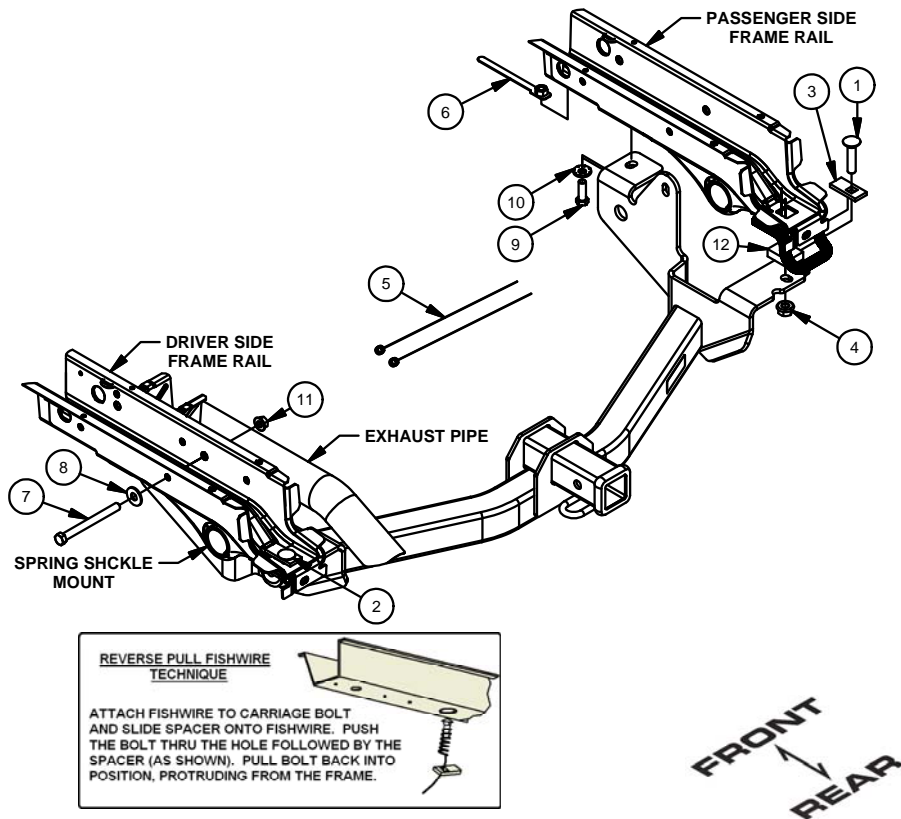

1. Remove the rearwardmost rubber plugs in the frame rails and foil (if present) covering the mounting holes. Return to owner. Fishwire the 9/16" x 2 1/2" carriage bolt and CM-SP70 spacer on the side with the recovery loop, and the 9/16" x 2" carriage bolt and CM-SP70 spacer into the holes that had the rubber plugs.

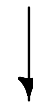

- 2a. Raise the hitch on the driver side with the forwardmost tab over the leaf spring and angle hitch to get the forwardmost tab on the passenger side over the leaf spring. Once in position, lift the driver side bracket up to the frame rail and slide the hitch over the rear bumper stud and the inner frame stud.



INSTALLATION WALKTHROUGH:

2b. Loosely secure driver side bracket with a 9/16" hex flange nut. Pushing the hitch toward the driver side, raise the passenger side bracket up to the frame. Slide the 13207-SP between the hitch and the frame with the bolt passing through and loosely secure with a 9/16" hex flange nut.

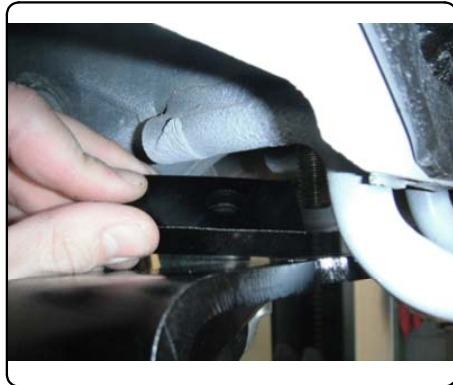
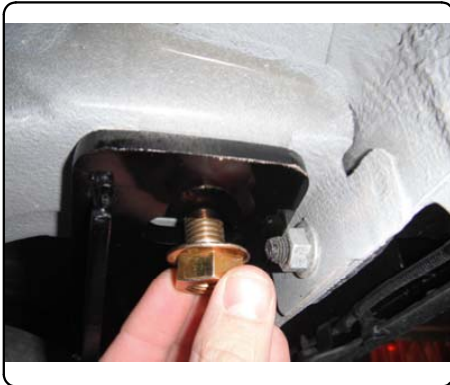

3. Slide the (2) 1/2" handle nuts into the grooved section of the frame over the forwardmost tabs and secure with 1/2" x 1 1/2" hex bolts and conical tooth washers. Slide the 1/2" x 5 1/2" hex bolts with washers through the frame and hitch brackets. Secure with 1/2" hex flange nuts.



4. Torque all 9/16" fasteners to 150 lb-ft and all 1/2" fasteners to 110 lb-ft.



TOWING SAFETY INFORMATION

Gross Trailer Weight / GTW

The Gross Trailer Weight is the weight of the trailer & cargo. Measure this by putting the fully loaded trailer on a vehicle scale.



Tongue Weight / TW

The downward force that is exerted on the hitch ball by the coupler. The tongue weight will vary depending on where the load is positioned in relationship to the trailer axle(s). To measure the tongue weight, use either a commercial scale or a bathroom scale with the coupler at towing height. When using a bathroom scale with heavier tongue weights, use the method shown and multiply the scale reading by 3.



Weight Carrying / WC

The total weight of both the trailer and the cargo inside. Never exceed the weight capacity of your trailer hitch.

Weight Distribution / WD

Used to balance the weight of the cargo between the front and rear wheels throughout the trailer, allowing for better steering, braking, and level riding.



Sway Control

A device used to reduce the lateral movements of the trailer that are caused by the wind. This works in conjunction with a weight distribution hitch. Do not use this on a class 1 or 2 hitch, or with surge brakes.

How Much Can You Safely Tow?

| TONGUE WEIGHT (lb) | 1000 | 2000 | 3000 | 4000 | 5000 | 6000 | 7000 | 8000 | 10,000 | 12,000 |
|---|------|------|------|------|------|------|------|------|--------|--------|
| Tongue weight should be about 10 to 15 percent of the gross trailer weight. | | | | | | | | | | |
| CLASS 1 | | | | | | | | | | |
| CLASS 2 | | | | | | | | | | |
| CLASS 3 | | | | | | | | | | |
| CLASS 4 | | | | | | | | | | |
| CLASS 5 | | | | | | | | | | |
| TRAILER TYPE | | | | | | | | | | |
| Camper | 11' | 12' | 13' | 14' | 15' | 16' | | | | |
| lbs. | 1100 | 1200 | 1300 | 1400 | 1500 | 1600 | | | | |
| Vacation | 18' | 19' | 20' | 21' | 22' | 24' | 26' | 28' | 30' | 32' |
| lbs. | 2100 | 2400 | 2700 | 3000 | 3300 | 3600 | 3900 | 4200 | 4500 | 4800 |
| Vacation | 18' | 19' | 20' | 21' | 22' | 24' | 26' | 28' | 30' | 32' |
| lbs. | 2800 | 3200 | 3600 | 4000 | 4400 | 4800 | 5200 | 5600 | 6000 | 6400 |
| 5th Wheel | | | | | | | | | | |

Refer to owner's manual for towing capabilities and limitations.

Ball Mount

The ball mount is placed inside the opening of the receiver hitch which is mounted to the vehicle. Make sure a hitch pin and clip is properly securing the ball mount to the receiver hitch before you begin towing.

- A: Rise. B: Drop. C: Hole Size. D: Length.



Trailer Ball

The connection from the hitch to the trailer. There are many factors that determine the correct hitch ball:

- Number one is the hitch ball's gross trailer weight rating.
- The mounting platform must be at least 3/8" thick.
- The hole diameter must not be more than 1/16" larger than the threaded shank.
- Every time you tow, check the nut and lock washer to make sure they are fastened securely.
- A: Ball Dia. B: Shank Length. C: Shank Dia. D: Shank Rise.

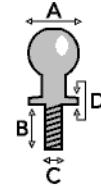

Coupler

The component that is placed over the trailer ball to connect the vehicle to the trailer. Be sure that the coupler size matches the size of the hitch ball and that the coupler handle is securely fastened. To determine what size hitch ball you need for your application you will need to know the size of coupler that is on the trailer. Be sure your coupler is properly adjusted to the ball you are using.

NOTE: For added security the use of safety devices such as Coupler Safety Pins and Locks is strongly recommended.

Safety Chains

Safety chains are a requirement and should be crossed under the tongue of the trailer so that the tongue will not drop to the road if it becomes separated from the hitch. Always leave enough slack so you can turn. Never allow the safety chains to drag on the ground and never attach the chains to the bumper.

Trailer Classification: Safety Chain Breaking Force - Minimum

Class 1: 2,000 lbs. (8.9 kN)

Class 2: 3,500 lbs. (15.6 kN)

Class 3: 5,000 lbs. (22.2 kN)

The strength rating of each length of safety chain or its equivalent and its attachments shall be equal to or exceed in minimum breaking force the GVWR (Gross Vehicle Weight Rating) of the trailer.

Electrical

Trailer lights, Electric Brakes, Break-away systems - Every time you tow, be sure to check that all components are working properly.

Wiring identification by color:

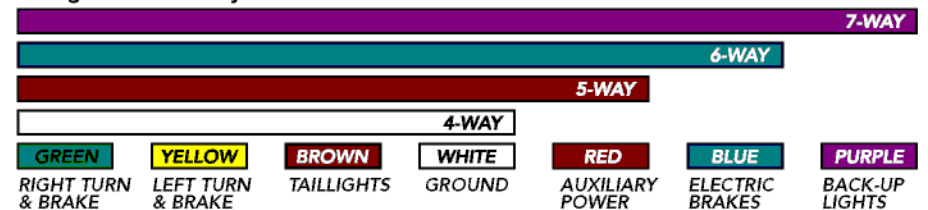

CURT DISCLAIMER: WIRING COLOR SHOWN WORK IN CONJUNCTION WITH CURT MANUFACTURING PRODUCTS.

13207**RAM Promaster****3/5/2015**

GROSS LOAD CAPACITY WHEN USED AS A WEIGHT CARRYING HITCH: 6,000 LBS. TRAILER WEIGHT & 750 LBS. TONGUE WEIGHT.
 GROSS LOAD CAPACITY WHEN USED AS A WEIGHT DISTRIBUTION HITCH: 7,500 LBS. TRAILER WEIGHT & 750 LBS. TONGUE WEIGHT

DO NOT EXCEED VEHICLE MANUFACTURER'S RECOMMENDED TOWING CAPACITY.

HAVING INSTALLATION QUESTIONS? CALL TECHNICAL SUPPORT AT 1-800-798-0813

| Parts List | | | |
|------------|-----|-----------------------------|--|
| ITEM | QTY | PART NUMBER | DESCRIPTION |
| 1 | 1 | 9_16-12 x 2.5 CARRIAGE BOLT | CARRIAGE BOLT |
| 2 | 1 | 9_16-12 x 2 CARRIAGE BOLT | CARRIAGE BOLT |
| 3 | 2 | CM-SP70 | .250 x 1.00 x 2.50" 9/16" SQUARE HOLE SPACER |
| 4 | 2 | 9_16-12 FLANGE NUT | HEX FLANGE NUT |
| 5 | 2 | 9_16 FISHWIRE | 9/16" FISHWIRE |
| 6 | 2 | 1/2-13 | HANDLE NUT |
| 7 | 2 | 1/2-13 x 5 1/2 | HEX BOLT |
| 8 | 2 | FW12 | FW, 12, ZP |
| 9 | 2 | 1_2 - 13 x 1 1_2 HEX, GR8 | HEX BOLT |
| 10 | 2 | 1/2 | CONICAL TOOTHED WASHER |
| 11 | 2 | HFN 1213, GR8 | HEX FLANGE NUT |
| 12 | 1 | 13207-SP | .625 x 2.00 SPACER |

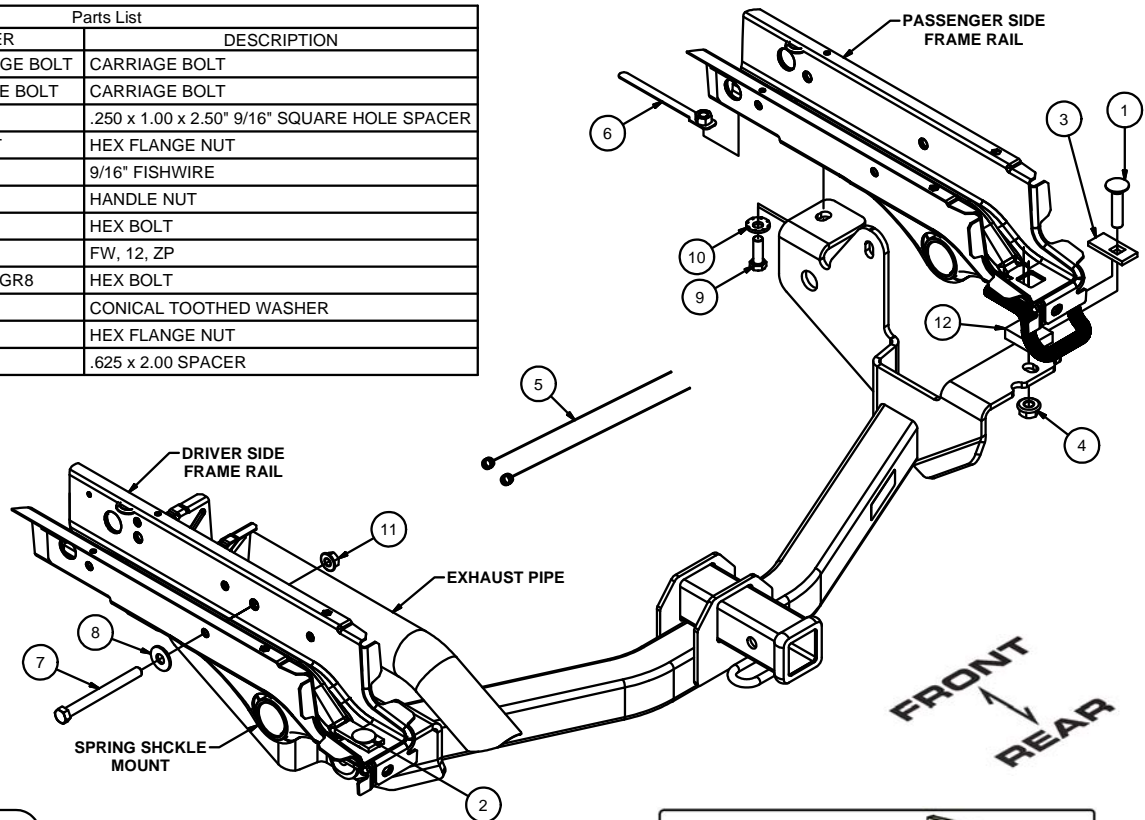

HITCH WEIGHT: 60 LBS.

INSTALL TIME

PROFESSIONAL: 20 MINUTES

NOVICE (DIY): 40 MINUTES

INSTALL NOTES:

- REMOVE RUBBER PLUGS
- REVERSE FISHWIRE
- NO DRILLING

TOOLS REQUIRED

RATCHET

TORQUE WRENCH

3/4" SOCKET

7/8" SOCKET

SMALL SCREW DRIVER

REVERSE PULL FISHWIRE TECHNIQUE

ATTACH FISHWIRE TO CARRIAGE BOLT AND SLIDE SPACER ONTO FISHWIRE. PUSH THE BOLT THRU THE HOLE FOLLOWED BY THE SPACER (AS SHOWN). PULL BOLT BACK INTO POSITION, PROTRUDING FROM THE FRAME.

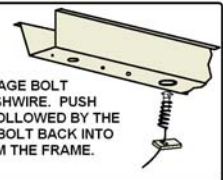

INSTALLATION STEPS

1. Remove the rearwardmost rubber plugs in the frame rails and foil (if present) covering the mounting holes. Return to owner. Fishwire the 9/16" x 2 1/2" carriage bolt and CM-SP70 spacer on the side with the recovery loop, and the 9/16" x 2" carriage bolt and CM-SP70 spacer into the holes that had the rubber plugs.
2. Raise the hitch on the driver side with the forwardmost tab over the leaf spring and angle hitch to get the forwardmost tab on the passenger side over the leaf spring. Once in position, lift the driver side bracket up to the frame rail and slide the hitch over the rear bumper stud and the inner frame stud, loosely secure with a 9/16" hex flange nut. Pushing the hitch toward the driver side, raise the passenger side bracket up to the frame. Slide the 13207-SP between the hitch and the frame with the bolt passing through and loosely secure with a 9/16" hex flange nut.
3. Slide the (2) 1/2" handle nuts into the grooved section of the frame over the forwardmost tabs and secure with 1/2" x 1 1/2" hex bolts and conical tooth washers. Slide the 1/2" x 5 1/2" hex bolts with washers through the frame and hitch brackets. Secure with 1/2" hex flange nuts.
4. Torque all 9/16" fasteners to 150 lb-ft and all 1/2" fasteners to 110 lb-ft.

PERIODICALLY CHECK THIS RECEIVER HITCH TO ENSURE THAT ALL FASTENERS ARE TIGHT AND THAT ALL STRUCTURAL COMPONENTS ARE SOUND.



Scan for more information

CURT Manufacturing LLC., warrants this product to be free of defects in material and/or workmanship at the time of retail purchase by the original purchaser. If the product is found to be defective, CURT Manufacturing LLC., may repair or replace the product, at their option, when the product is returned, prepaid, with proof of purchase. Alteration to, misuse of, or improper installation of this product voids the warranty. CURT Manufacturing LLC.'s liability is limited to repair or replacement of products found to be defective, and specifically excludes liability for incidental or consequential loss or damage.