

13352

04-05 FORD F-150

9/21/2012

GROSS LOAD CAPACITY WHEN USED AS A WEIGHT CARRYING HITCH: 6000 LBS. TRAILER WEIGHT & 600 LBS. TONGUE WEIGHT.  
 GROSS LOAD CAPACITY WHEN USED AS A WEIGHT DISTRIBUTION HITCH: 10000 LBS. TRAILER WEIGHT & 1000 LBS. TONGUE WEIGHT  
**\*\*\*DO NOT EXCEED VEHICLE MANUFACTURER'S RECOMMENDED TOWING CAPACITY.\*\*\***

Parts List			
ITEM	QTY	PART NUMBER	DESCRIPTION
1	1	1/2"	FISHWIRE TOOL
2	6	1/2-13 x 1 3/4	CARRIAGE BOLT
3	6	CM-SP6	.250 x 1.00 x 3.00" SQUARE HOLE SPACER
4	6	HFN 1213	HEX FLANGE NUT
5	2	5/8-11 x 1 1/2	HEX BOLT
6	2	5/8	WASHER
7	2	5/8-11	HEX FLANGE NUT

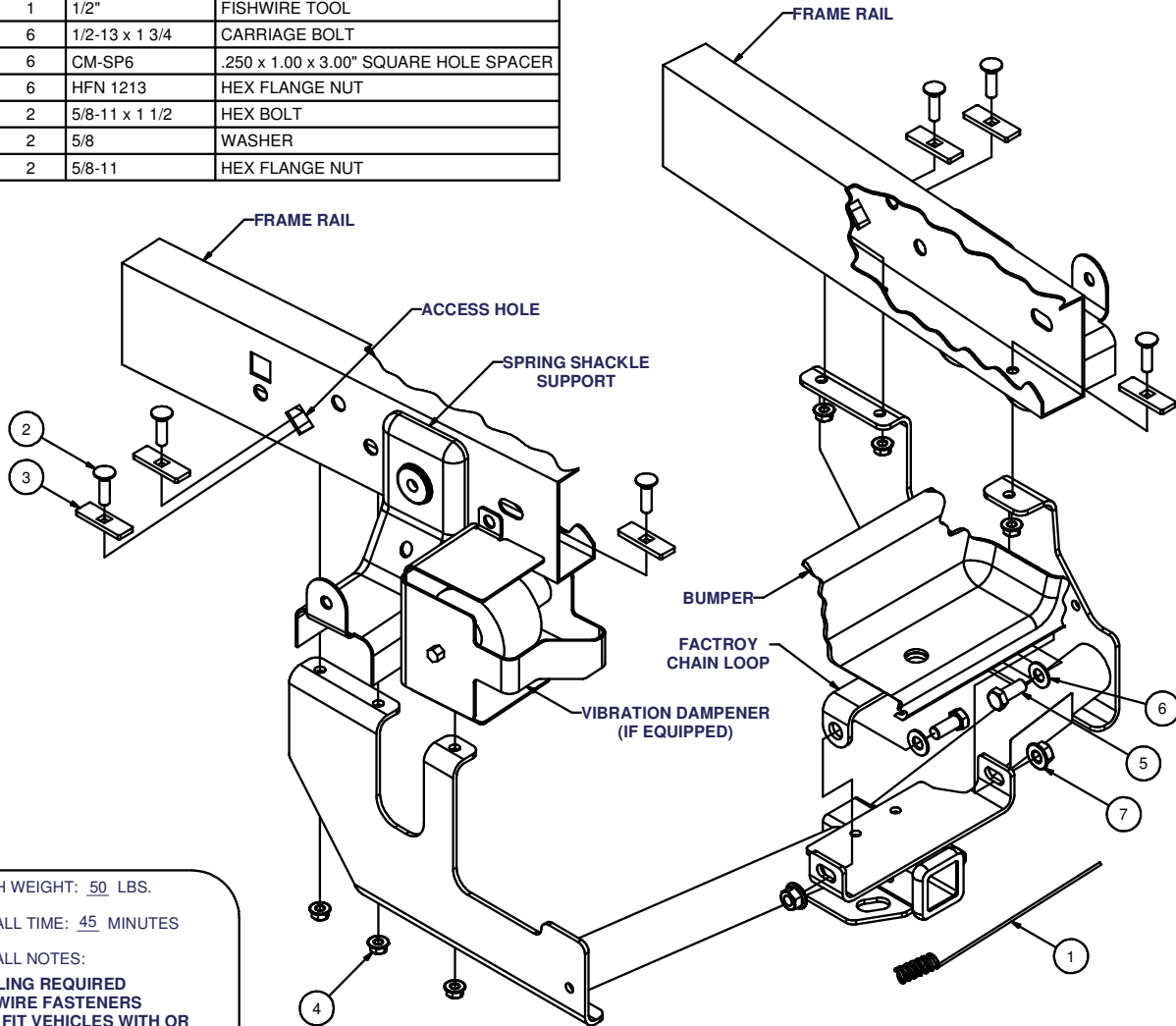

HITCH WEIGHT: 50 LBS.

INSTALL TIME: 45 MINUTES

INSTALL NOTES:

- DRILLING REQUIRED
- FISHWIRE FASTENERS
- WILL FIT VEHICLES WITH OR WITHOUT VIBRATION DAMPENER

## INSTALLATION STEPS

- 1) Raise hitch into position and insert 5/8" hex bolts and washers through factory chain loop holes and holes in top plate of hitch, secure with flange nuts.
- 2) Using the hitch as a template mark and drill (3) 1/2" mounting holes in each frame rail.
- 3) Attach the hitch to the rearmost frame holes by inserting 1/2" carriage bolts and spacer into open end of frame and out hitch mounting holes, secure with flange nuts.
- 4) Fishwire remaining 1/2" carriage bolts and spacers through access holes located on the side of each frame rail and through drilled holes as shown, secure with flange nuts.
- 5) Torque all 1/2" fasteners to 110 lb.-ft. and all 5/8" fasteners to 210 lb.-ft.

**PERIODICALLY CHECK THIS RECEIVER HITCH TO ENSURE THAT ALL FASTENERS ARE TIGHT AND THAT ALL STRUCTURAL COMPONENTS ARE SOUND.**

Curt Manufacturing Inc., warrants this product to be free of defects in material and/or workmanship at the time of retail purchase by the original purchaser. If the product is found to be defective, Curt Manufacturing Inc., may repair or replace the product, at their option, when the product is returned, prepaid, with proof of purchase. Alteration to, misuse of, or improper installation of this product voids the warranty. Curt Manufacturing Inc.'s liability is limited to repair or replacement of products found to be defective, and specifically excludes liability for incidental or consequential loss or damage.