

INSTALLATION MANUAL

13493

Level of Difficulty

Easy

Installation difficulty levels are based on time and effort involved and may vary depending on the installer level of expertise, condition of the vehicle and proper tools and equipment.

Weight Carrying Capacity

Gross trailer weight (GTW)	3,500 lbs.
Tongue weight (TW)	350 lbs.

Weight Distribution Capacity

Weight distribution (WD)	4,000 lbs.
WD tongue weight (WDTW)	400 lbs.

Parts List

Item	Qty	Description
1	4	Hex bolt, 1/2"
2	4	Conical-toothed washer, 1/2"
3	4	Serrated-flange nut, 1/2"

Tools Required

Ratchet	Wrench, 3/4"
Socket, 3/4"	Torque wrench

* For a tools reference guide visit curtmfg.com/trailer-hitch-installation

⚠ WARNING

Never exceed the vehicle manufacturer's recommended towing capacity.

Product Photo



NOTICE

Visit www.curtmfg.com for a full-color copy of this instruction manual, as well as helpful videos, guides and much more!

Before you begin installation, read all instructions thoroughly.

Proper tools will improve the quality of installation and reduce the time required.

Periodic inspection of the trailer hitch should be performed to ensure all mounting hardware remains tight and structural components are secure.

To help prevent damage to the product or vehicle, refer to the specified torque specifications when securing hardware during the installation process.

SAFETY INSTRUCTIONS

Safety glasses should be worn at all times while installing this product.

Product Registration and Warranty

CURT stands behind our products with industry-leading warranties. To get copies of the product warranties, register your purchase or provide feedback, visit: warranty.curtgroup.com/surveys

ASSEMBLY

Parts List

Item	Qty	Description
1	4	Hex bolt, 1/2"
2	4	Conical-toothed washer, 1/2"
3	4	Serrated-flange nut, 1/2"

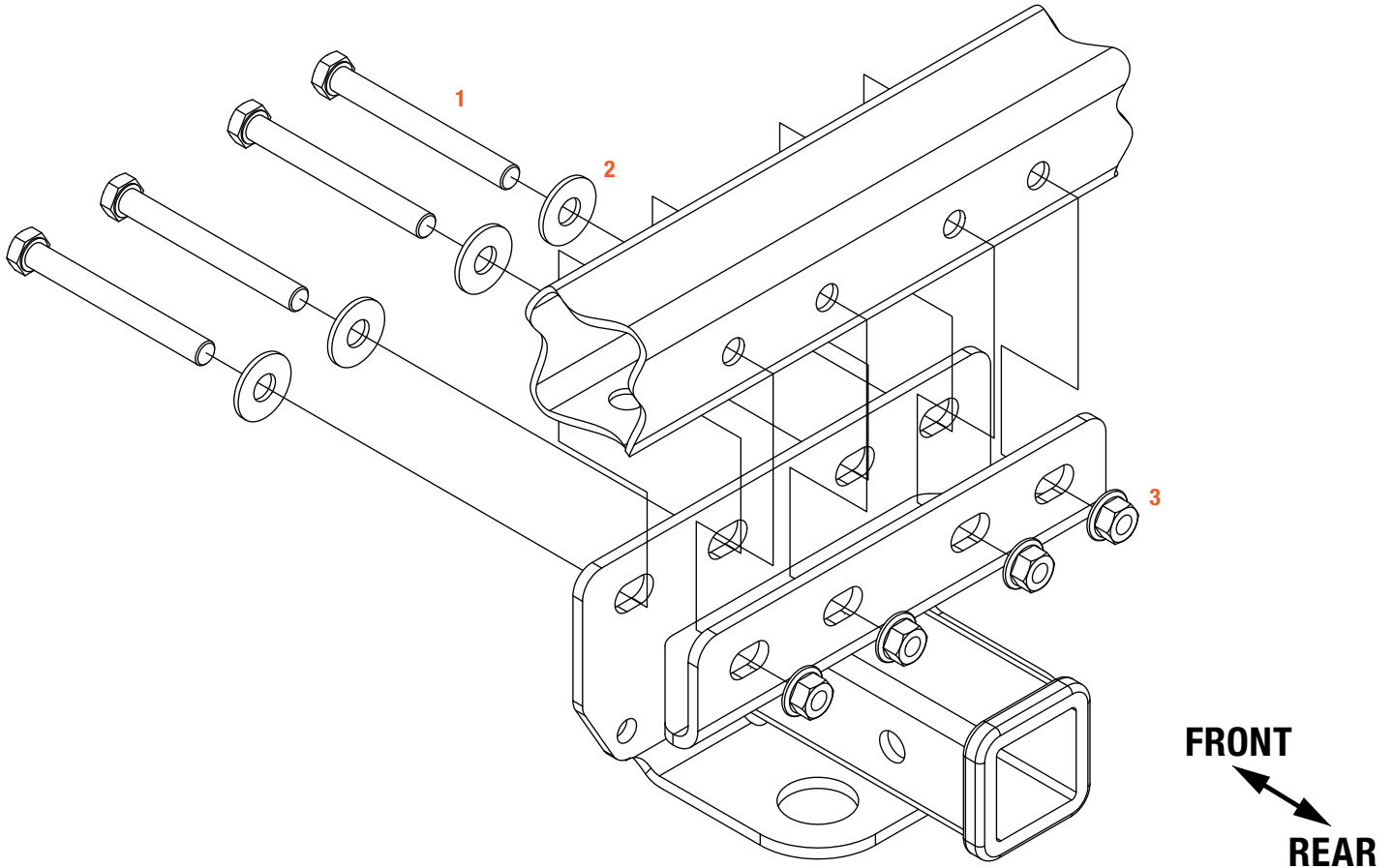

CONICAL TOOTHED WASHER ORIENTATION

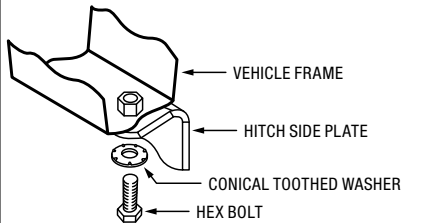

Step 1

Raise the hitch into position around the bumper beam and insert four 1/2" hex bolts (#1) and four serrated conical toothed washers (#2) through the hitch and holes in bumper beam. Loosely secure with 1/2" serrated flange nuts (#3).

Torque 1/2" hardware to 110 ft-lbs.



Final Installed Image



TOWING BASICS & SAFETY INFORMATION

For information on safely towing your trailer, visit curtmfg.com/understanding-towing.