

15320

CHEVROLET EXPRESS / GMC SAVANA

10/19/2012

GROSS LOAD CAPACITY WHEN USED AS A WEIGHT CARRYING HITCH: 16,000 LBS. TRAILER WEIGHT & 2,400 LBS. TONGUE WEIGHT.
GROSS LOAD CAPACITY WHEN USED AS A WEIGHT DISTRIBUTION HITCH: 17,000 LBS. TRAILER WEIGHT & 2,400 LBS. TONGUE WEIGHT

DO NOT EXCEED VEHICLE MANUFACTURER'S RECOMMENDED TOWING CAPACITY.

HAVING INSTALLATION QUESTIONS? CALL TECHNICAL SUPPORT AT 1-800-798-0813

Parts List			
ITEM	QTY	PART NUMBER	DESCRIPTION
1	2	9_16-12 x 1 1/2	CARRIAGE BOLT
2	2	CM-SP70	.250 x 1.00 x 2.50" 9/16" SQUARE HOLE SPACER
3	2	9_16-12 FLANGE NUT	HEX FLANGE NUT
4	1	9_16 FISHWIRE	9/16" FISHWIRE
5	4	1/2-13 x 1 1/2	CARRIAGE BOLT
6	4	CM-SP10	.250 x 1.00 x 2.50" SQUARE HOLE SPACER
7	4	HFN 1213	HEX FLANGE NUT
8	2	1_2 FISHWIRE	1/2" FISHWIRE

TOOLS REQUIRED
RATCHET
3/4" & 7/8" SOCKET
TORQUE WRENCH

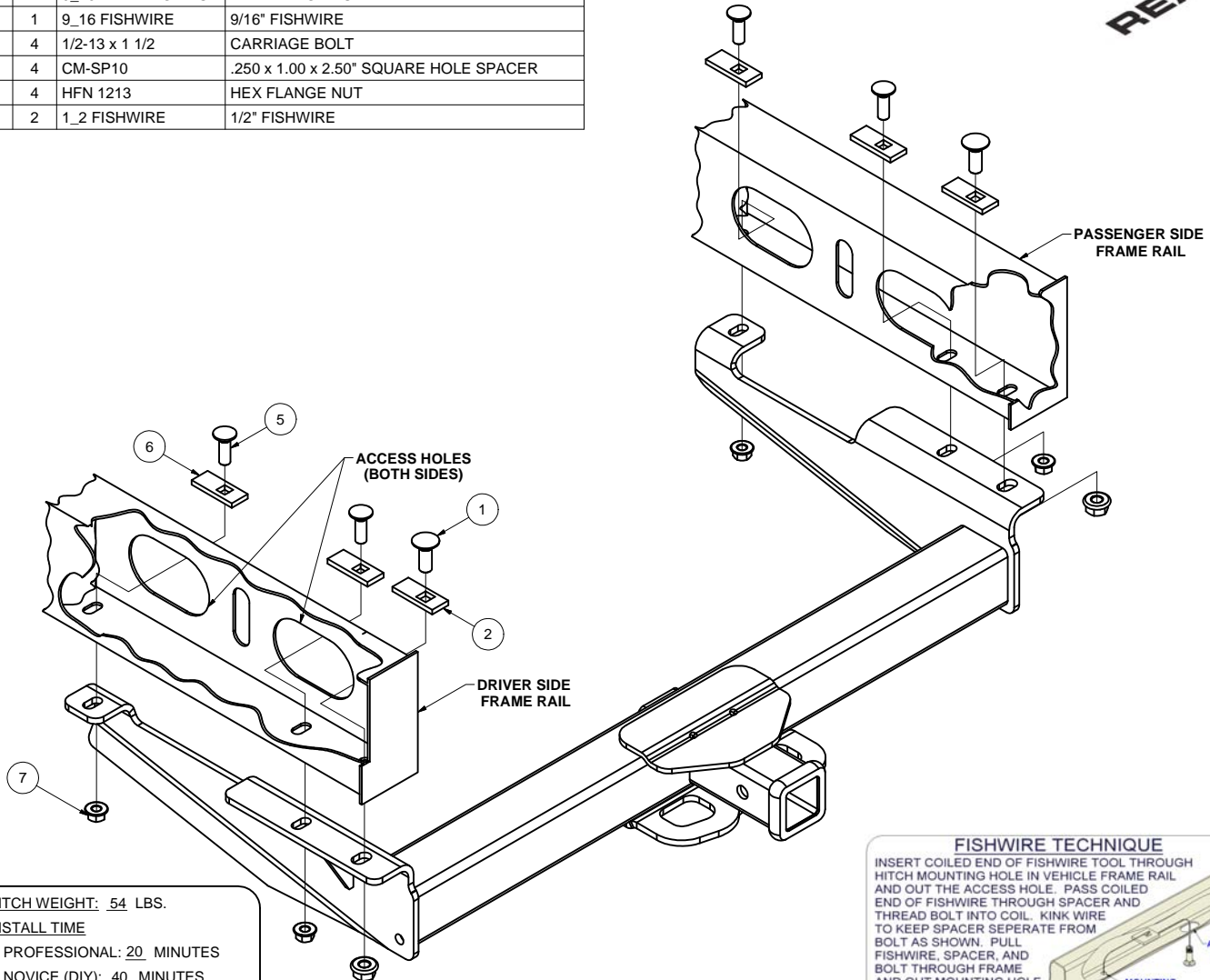

FISHWIRE TECHNIQUE

INSERT COILED END OF FISHWIRE TOOL THROUGH HITCH MOUNTING HOLE IN VEHICLE FRAME RAIL AND OUT THE ACCESS HOLE. PASS COILED END OF FISHWIRE THROUGH SPACER AND THREAD BOLT INTO COIL. KINK WIRE TO KEEP SPACER SEPARATE FROM BOLT AS SHOWN. PULL FISHWIRE, SPACER, AND BOLT THROUGH FRAME AND OUT MOUNTING HOLE. USE FISHWIRE TO GUIDE HITCH DURING MOUNTING AND PREVENT LOSS OF BOLT / SPACER INSIDE FRAME RAIL.

****NOTE: SOME VEHICLES MAY FISHWIRE THROUGH END OF FRAME****

HITCH WEIGHT: 54 LBS.

INSTALL TIME

PROFESSIONAL: 20 MINUTES

NOVICE (DIY): 40 MINUTES

INSTALL NOTES:

- NO DRILLING REQUIRED
- FISHWIRE IF NECESSARY

INSTALLATION STEPS

1. Install all hardware and spacers, as shown above. Using fishwires may help to pull hardware through holes in frame rails. **NOTE:** Be sure 9/16" hardware is used in the vehicles rearmost mounting locations.
2. Raise hitch into position and attach with hex flange nuts, as shown above.
3. Torque all 1/2" hardware to 110 ft-lbs and all 9/16" hardware to 150 ft-lbs.

PERIODICALLY CHECK THIS RECEIVER HITCH TO ENSURE THAT ALL FASTENERS ARE TIGHT AND THAT ALL STRUCTURAL COMPONENTS ARE SOUND.

Curt Manufacturing LLC., warrants this product to be free of defects in material and/or workmanship at the time of retail purchase by the original purchaser. If the product is found to be defective, Curt Manufacturing LLC., may repair or replace the product, at their option, when the product is returned, prepaid, with proof of purchase. Alteration to, misuse of, or improper installation of this product voids the warranty. Curt Manufacturing LLC.'s liability is limited to repair or replacement of products found to be defective, and specifically excludes liability for incidental or consequential loss or damage.