

**15410****FORD F-250 / F-350 SUPER DUTY****9/10/2012**

**GROSS LOAD CAPACITY WHEN USED AS A WEIGHT CARRYING HITCH: 17,000 LBS. TRAILER WEIGHT & 2,550 LBS. TONGUE WEIGHT.  
 GROSS LOAD CAPACITY WHEN USED AS A WEIGHT DISTRIBUTION HITCH: 17,000 LBS. TRAILER WEIGHT & 2,550 LBS. TONGUE WEIGHT**

**\*\*\*DO NOT EXCEED VEHICLE MANUFACTURER'S RECOMMENDED TOWING CAPACITY.\*\*\***

**HAVING INSTALLATION QUESTIONS? CALL TECHNICAL SUPPORT AT 1-800-798-0813**

Parts List			
ITEM	QTY	PART NUMBER	DESCRIPTION
1	8	9_16-12 x 1 3/4	CARRIAGE BOLT
2	8	CM-SP71	.250 x 1.50 x 2.00" 9/16" SQUARE HOLE SPACER
3	8	9_16-12 FLANGE NUT	HEX FLANGE NUT

**TOOLS REQUIRED**

13/16" WRENCH

7/8" SOCKET

12" EXTENSION

SOCKET WRENCH

TORQUE WRENCH

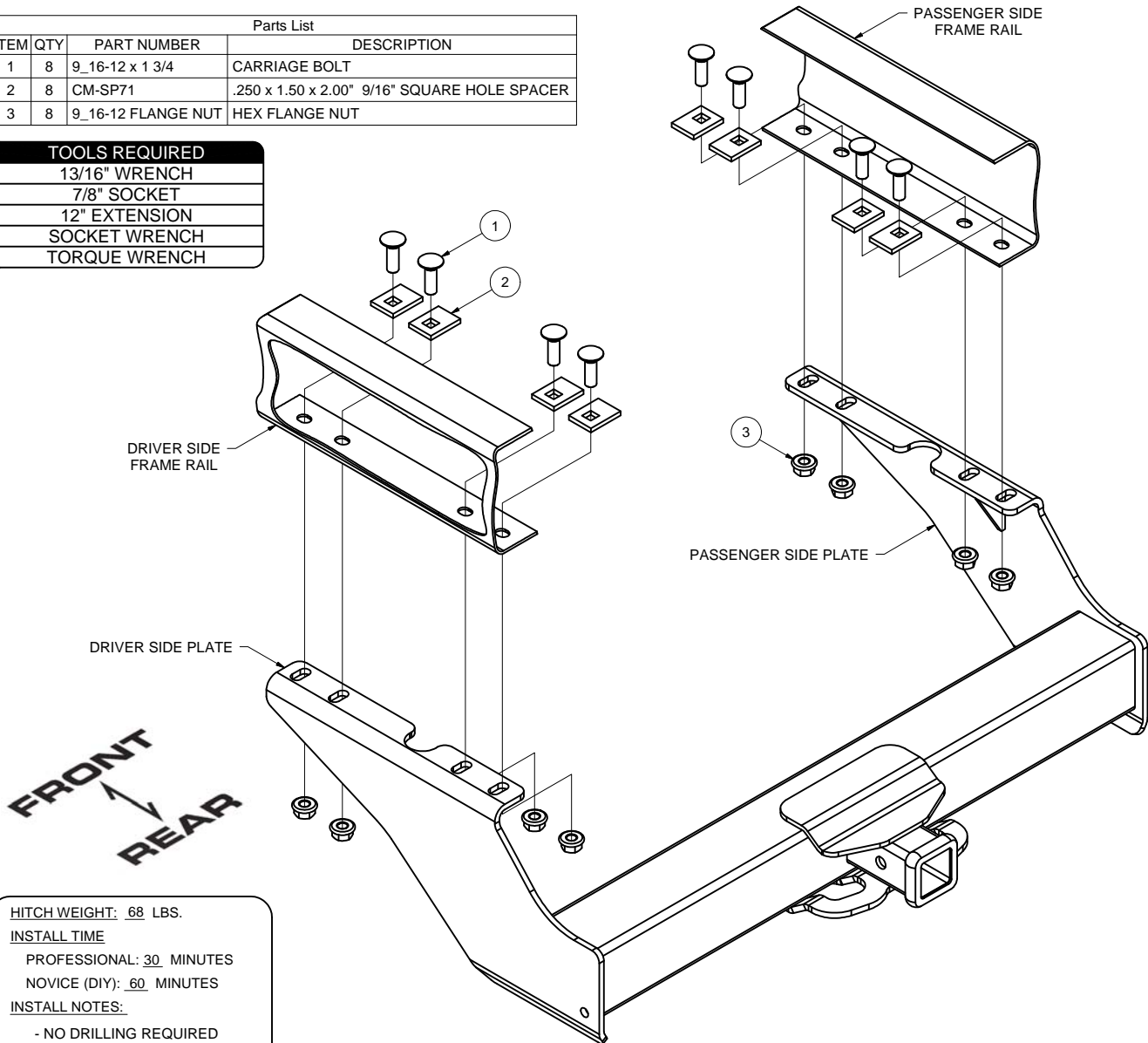
**HITCH WEIGHT:** 68 LBS.**INSTALL TIME**

PROFESSIONAL: 30 MINUTES

NOVICE (DIY): 60 MINUTES

**INSTALL NOTES:**

- NO DRILLING REQUIRED

**INSTALLATION STEPS**

**Note:** To ease installation, removal of the spare tire is recommended.

1. Position the hitch against the frame, aligning the holes in the hitch with the holes in the frame. Take note of the fastener locations and lower the hitch.
2. Place a carriage bolt and spacer into each bolt location from inside the frame rail as shown.
3. Raise the hitch into position and secure it to the frame rails using hex flange nuts, as shown.
4. Torque all hardware to 150 lb-ft.

PERIODICALLY CHECK THIS RECEIVER HITCH TO ENSURE THAT ALL FASTENERS ARE TIGHT AND THAT ALL STRUCTURAL COMPONENTS ARE SOUND.

Curt Manufacturing LLC., warrants this product to be free of defects in material and/or workmanship at the time of retail purchase by the original purchaser. If the product is found to be defective, Curt Manufacturing LLC., may repair or replace the product, at their option, when the product is returned, prepaid, with proof of purchase. Alteration to, misuse of, or improper installation of this product voids the warranty. Curt Manufacturing LLC.'s liability is limited to repair or replacement of products found to be defective, and specifically excludes liability for incidental or consequential loss or damage.