

GROSS LOAD CAPACITY WHEN USED AS A WEIGHT CARRYING HITCH: 15,000 LBS. TRAILER WEIGHT & 1,500 LBS. TONGUE WEIGHT.
 GROSS LOAD CAPACITY WHEN USED AS A WEIGHT DISTRIBUTION HITCH: 16,000 LBS. TRAILER WEIGHT & 1,600 LBS. TONGUE WEIGHT

***** DO NOT EXCEED VEHICLE MANUFACTURER'S RECOMMENDED TOWING CAPACITY.*****

Parts List			
ITEM	QTY	PART NUMBER	DESCRIPTION
1	6	1/2-13 x 1 3/4	CARRIAGE BOLT
2	6	CM-SP1	.250 x 1.50 x 2.00" SQUARE HOLE SPACER
3	7	HFN 1213	HEX FLANGE NUT
4	8	7/16-14 x 1 1/4	CARRIAGE BOLT
5	8	7/16-14	LARGE HEX FLANGE NUT

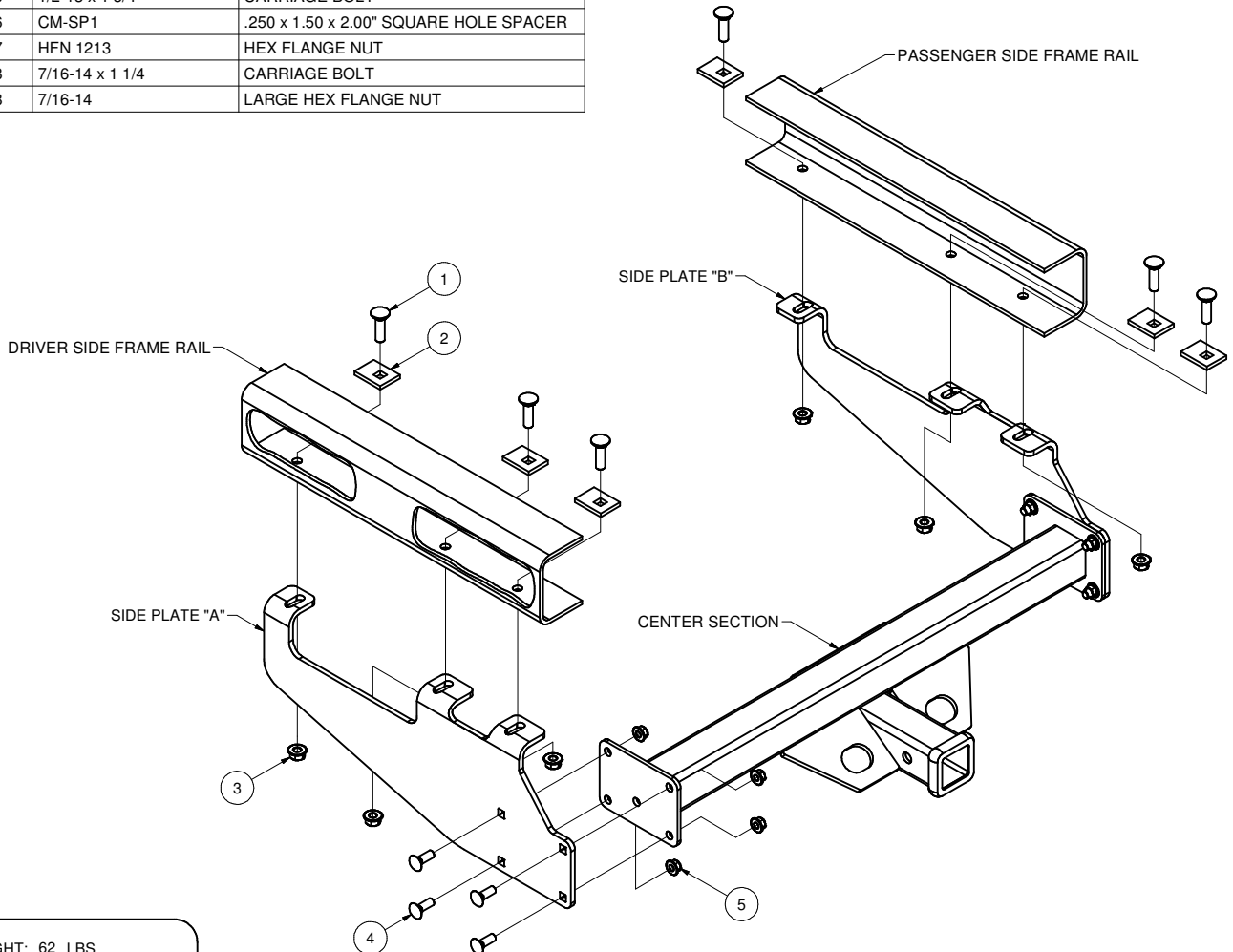

HITCH WEIGHT: 62 LBS.
 INSTALL TIME: 60 MINUTES
 INSTALL NOTES:
 - DRILLING REQUIRED

INSTALLATION STEPS

- 1) Bolt the center section to side plates "A" and "B" with the 7/16" carriage bolts and hex flange nuts as shown.
- 2) Raise the hitch into position by placing the back edge of the side plate against forward rivet. Hold the hitch in position using locking pliers or c-clamps and mark the locations of the holes to be drilled.
- 3) Remove the hitch and drill the (6) 17/32" holes.
- 4) Place a CM-SP1 spacer onto each of the 1/2" bolts and install in the holes as shown. Raise hitch into position and secure using the 1/2" hex flange nuts provided.
- 5) Torque all 1/2" hardware to 110 ft-lbs. Torque all 7/16" hardware to 70 ft-lbs.

PERIODICALLY CHECK THIS RECEIVER HITCH TO ENSURE THAT ALL FASTENERS ARE TIGHT AND THAT ALL STRUCTURAL COMPONENTS ARE SOUND.

Curt Manufacturing Inc., warrants this product to be free of defects in material and/or workmanship at the time of retail purchase by the original purchaser. If the product is found to be defective, Curt Manufacturing Inc., may repair or replace the product, at their option, when the product is returned, prepaid, with proof of purchase. Alteration to, misuse of, or improper installation of this product voids the warranty. Curt Manufacturing Inc.'s liability is limited to repair or replacement of products found to be defective, and specifically excludes liability for incidental or consequential loss or damage.

15511**1962-1987 CHEVY/GMC F/S PICKUP, EXCEPT SHORT BED (WITH 10" STEP BUMPER)
1988-CURRENT CHEVY/GMC CAB AND CHASSIS, (WITH 10" STEP BUMPER AND 34" FRAME WIDTH)**

6/14/2012

Page 2 of 4

GROSS LOAD CAPACITY WHEN USED AS A WEIGHT CARRYING HITCH: 15,000 LBS. TRAILER WEIGHT & 1,500 LBS. TONGUE WEIGHT.
GROSS LOAD CAPACITY WHEN USED AS A WEIGHT DISTRIBUTION HITCH: 16,000 LBS. TRAILER WEIGHT & 1,600 LBS. TONGUE WEIGHT

***** DO NOT EXCEED VEHICLE MANUFACTURER'S RECOMMENDED TOWING CAPACITY. *****

Parts List				
ITEM	QTY	PART NUMBER	DESCRIPTION	
1	6	1/2-13 x 1 3/4	CARRIAGE BOLT	
2	6	CM-SP1	.250 x 1.50 x 2.00" SQUARE HOLE SPACER	
3	7	HFN 1213	HEX FLANGE NUT	
4	8	7/16-14 x 1 1/4	CARRIAGE BOLT	
5	8	7/16-14	LARGE HEX FLANGE NUT	
6	2	CM-SP4	.250 x 1.50 x 3.00" SQUARE HOLE SPACER	
7	1	1/2 - 13 x 1 1/2	HEX BOLT	
8	1	CM-SP141	SPARE TIRE "L" BRACKET	

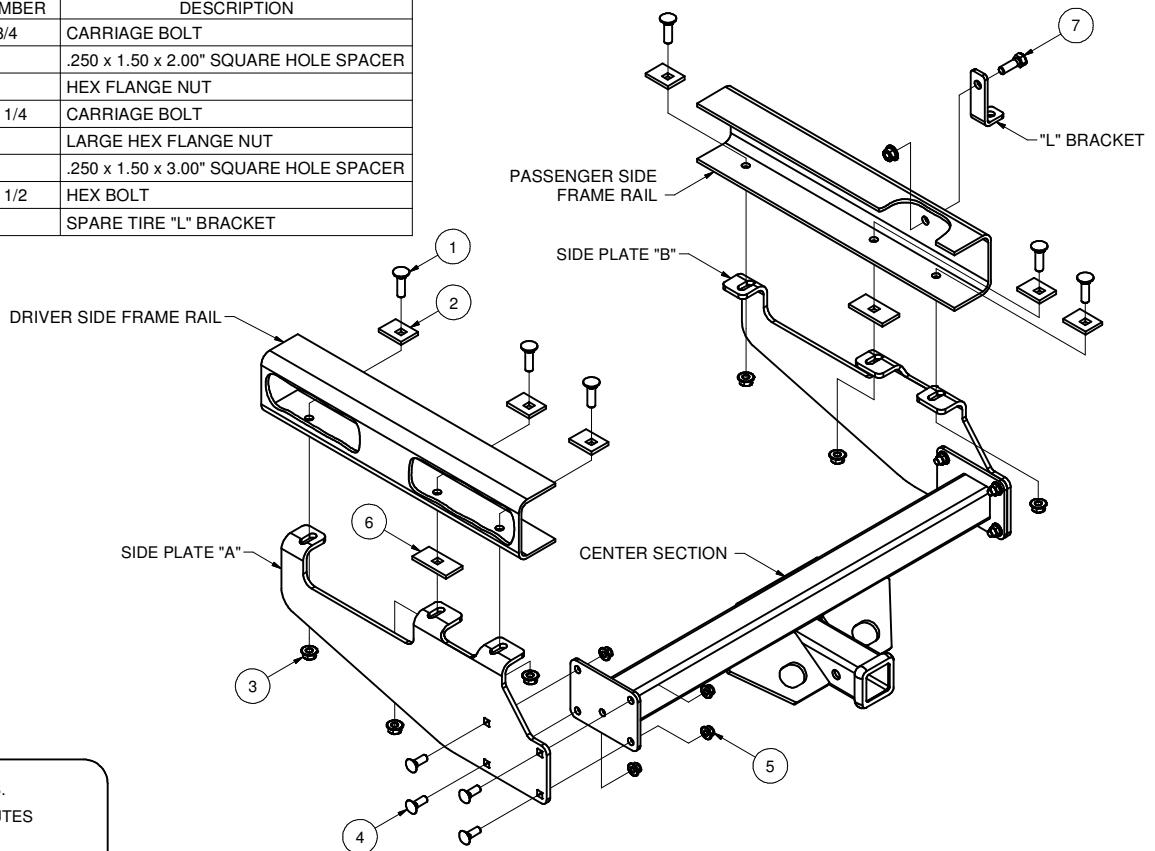

HITCH WEIGHT: 62 LBS.
INSTALL TIME: 60 MINUTES
INSTALL NOTES:
- RELOCATE SPARE TIRE

INSTALLATION STEPS

- 1) Temporarily remove the spare tire.
- 2) Remove and discard the bumper reinforcement brackets. (They are no longer required as the bumper will no longer be used for towing.)
- 3) Bolt the center section to side plates "A" and "B" with the 7/16" carriage bolts and hex flange nuts as shown.
- 4) Place a CM-SP1 spacer and 1/2" bolt and into each of the forward most holes in the frame rails.
- 5) Raise the hitch into position and secure loosely using a 1/2" hex flange nut.
- 6) Install a CM-SP1 spacer and 1/2" carriage bolt into each center bolt location and secure using a CM-SP4 spacer and 1/2" hex flange nut as shown.
- 7) Install a CM-SP1 spacer and 1/2" carriage bolt into the rearmost bolt location and secure using 1/2" hex flange nuts as shown.
- 8) Torque all 1/2" hardware to 110 ft-lbs. Torque all 7/16" hardware to 70 ft-lbs.
- 9) Position the spare tire "L" bracket approximately 6" forward from the previous location and install the spare tire carrier bolt.
- 10) Replace spare tire and tighten securely.

PERIODICALLY CHECK THIS RECEIVER HITCH TO ENSURE THAT ALL FASTENERS ARE TIGHT AND THAT ALL STRUCTURAL COMPONENTS ARE SOUND.

Curt Manufacturing Inc., warrants this product to be free of defects in material and/or workmanship at the time of retail purchase by the original purchaser. If the product is found to be defective, Curt Manufacturing Inc., may repair or replace the product, at their option, when the product is returned, prepaid, with proof of purchase. Alteration to, misuse of, or improper installation of this product voids the warranty. Curt Manufacturing Inc.'s liability is limited to repair or replacement of products found to be defective, and specifically excludes liability for incidental or consequential loss or damage.

GROSS LOAD CAPACITY WHEN USED AS A WEIGHT CARRYING HITCH: 15,000 LBS. TRAILER WEIGHT & 1,500 LBS. TONGUE WEIGHT.
GROSS LOAD CAPACITY WHEN USED AS A WEIGHT DISTRIBUTION HITCH: 16,000 LBS. TRAILER WEIGHT & 1,600 LBS. TONGUE WEIGHT

*** DO NOT EXCEED VEHICLE MANUFACTURER'S RECOMMENDED TOWING CAPACITY.***

Parts List			
ITEM	QTY	PART NUMBER	DESCRIPTION
1	6	1/2-13 x 1 3/4	CARRIAGE BOLT
2	6	CM-SP1	.250 x 1.50 x 2.00" SQUARE HOLE SPACER
3	7	HFN 1213	HEX FLANGE NUT
4	8	7/16-14 x 1 1/4	CARRIAGE BOLT
5	8	7/16-14	LARGE HEX FLANGE NUT
6	2	CM-SP4	.250 x 1.50 x 3.00" SQUARE HOLE SPACER

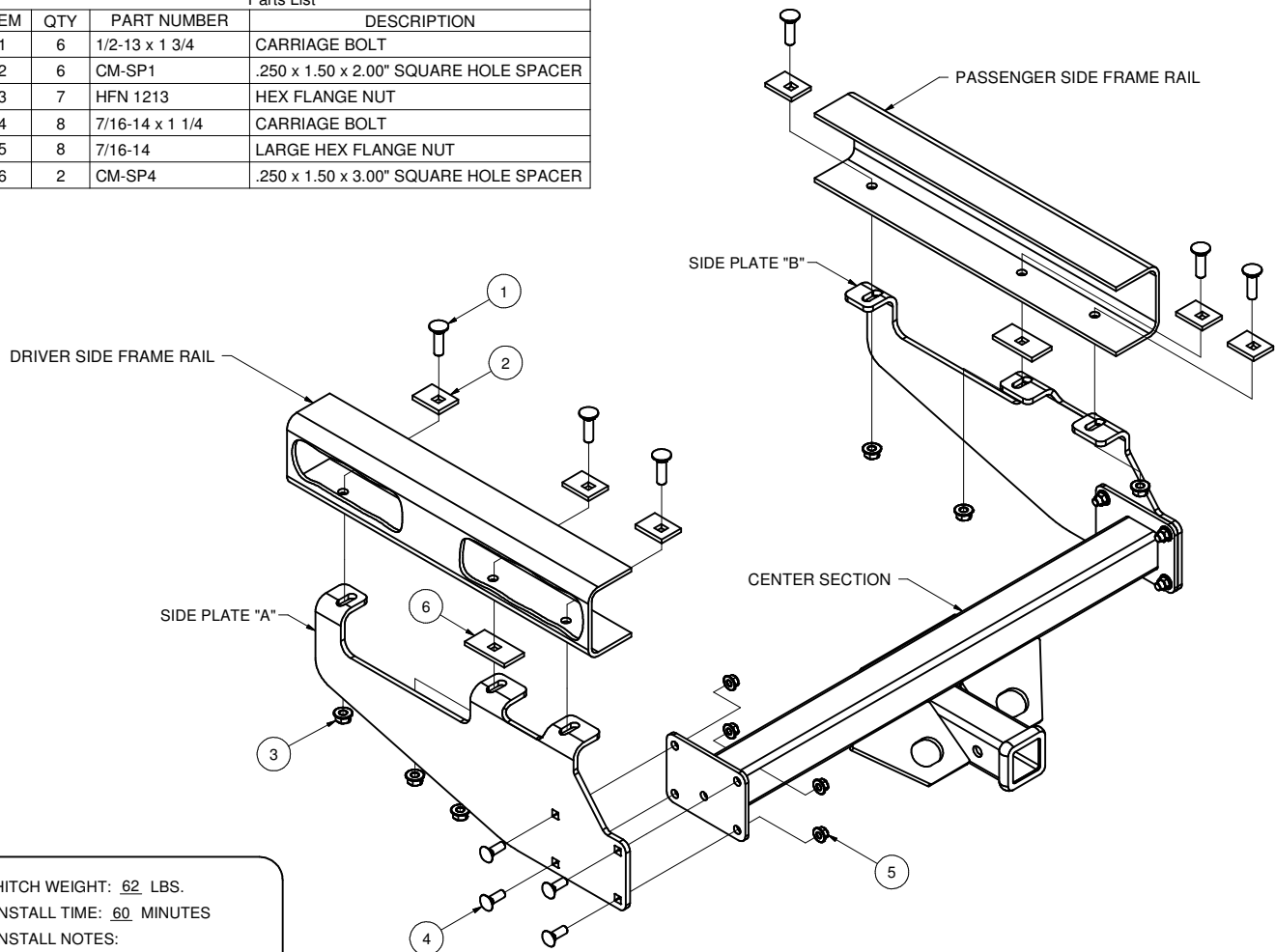

HITCH WEIGHT: 62 LBS.
INSTALL TIME: 60 MINUTES
INSTALL NOTES:
- DRILLING REQUIRED

INSTALLATION STEPS

- 1) Bolt center section to sideplates "A" and "B" with the 7/16" carriage bolts and hex flange nuts as shown. (Mount end plates as shown for 37 1/2" frames, face flange inward for 34" frames.)
- 2) Loosen the spare tire bracket to allow room to position the hitch. Align the hitch under the vehicle such that the frame rivet is just forward of the rear most flange of the plate. Use locking pliers or c-clamps to keep the hitch in position for drilling.
- 3) Using a 17/32" drill bit, drill the frame through the (6) slots in the side plates. Drill the holes as far to the outboard side of the frame rail as possible to ensure maximum strength.
- 4) Slide CM-SP4 spacers between the frame and flange as shown and secure the hitch with the (6) 1/2"-13 carriage bolts and CM-SP1 spacers as shown.
- 5) Torque all 1/2" hardware to 110 ft-lbs. Torque all 7/16" hardware to 70 ft-lbs.
- 6) Retighten spare tire bracket.

PERIODICALLY CHECK THIS RECEIVER HITCH TO ENSURE THAT ALL FASTENERS ARE TIGHT AND THAT ALL STRUCTURAL COMPONENTS ARE SOUND.

Curt Manufacturing Inc., warrants this product to be free of defects in material and/or workmanship at the time of retail purchase by the original purchaser. If the product is found to be defective, Curt Manufacturing Inc., may repair or replace the product, at their option, when the product is returned, prepaid, with proof of purchase. Alteration to, misuse of, or improper installation of this product voids the warranty. Curt Manufacturing Inc.'s liability is limited to repair or replacement of products found to be defective, and specifically excludes liability for incidental or consequential loss or damage.

15511 1972 - 1995 DODGE TRUCK (ALL FULL SIZE WITH 10" STEP BUMPER)

6/14/2012

Page 4 of 4

GROSS LOAD CAPACITY WHEN USED AS A WEIGHT CARRYING HITCH: 15,000 LBS. TRAILER WEIGHT & 1,500 LBS. TONGUE WEIGHT.
GROSS LOAD CAPACITY WHEN USED AS A WEIGHT DISTRIBUTION HITCH: 16,000 LBS. TRAILER WEIGHT & 1,600 LBS. TONGUE WEIGHT

***** DO NOT EXCEED VEHICLE MANUFACTURER'S RECOMMENDED TOWING CAPACITY.*****

Parts List				
ITEM	QTY	PART NUMBER	DESCRIPTION	
1	6	1/2-13 x 1 3/4	CARRIAGE BOLT	
2	6	CM-SP1	.250 x 1.50 x 2.00" SQUARE HOLE SPACER	
3	7	HFN 1213	HEX FLANGE NUT	
4	8	7/16-14 x 1 1/4	CARRIAGE BOLT	
5	8	7/16-14	LARGE HEX FLANGE NUT	

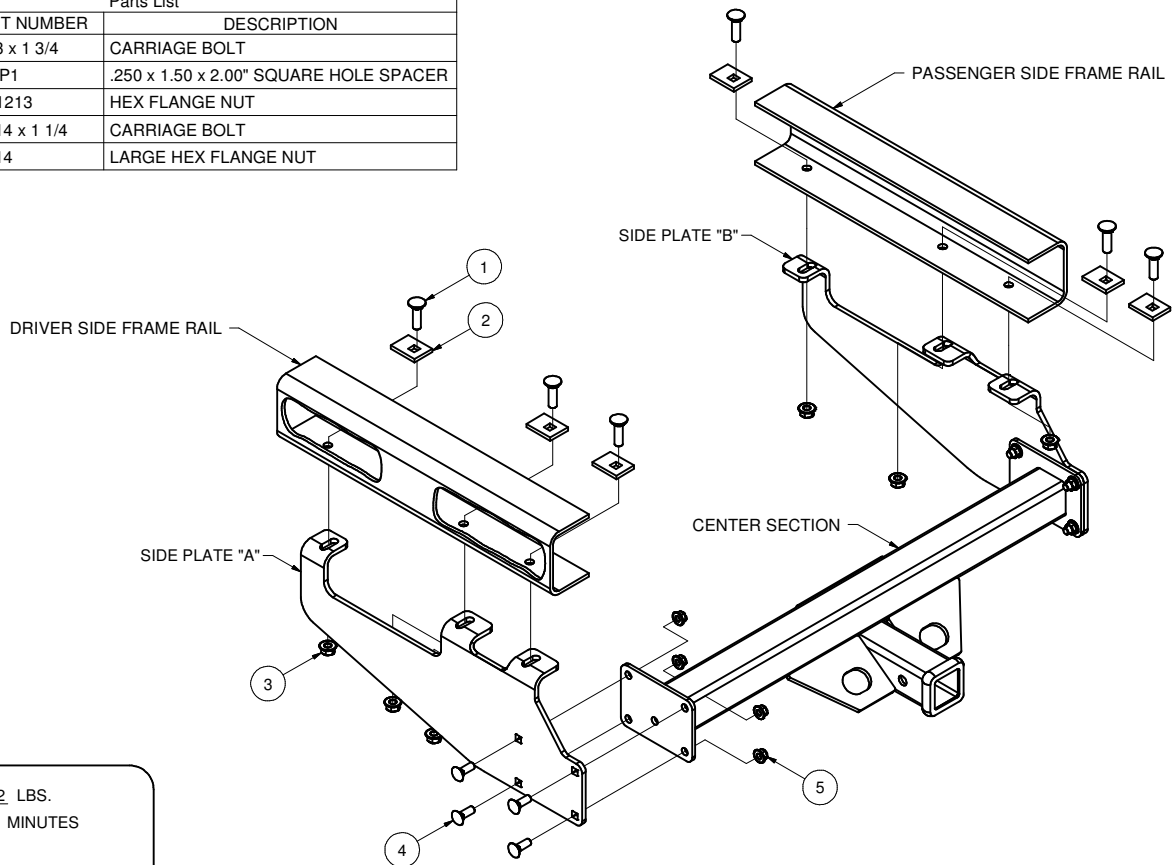

HITCH WEIGHT: 62 LBS.
INSTALL TIME: 60 MINUTES
INSTALL NOTES:
- DRILLING REQUIRED

INSTALLATION STEPS

1. (1972 - 1993) Remove spare tire and hanger bolt.
(1994 - 1995) Remove rear exhaust hanger bracket.
2. Bolt center section to side plates "A" and "B" with the 7/16" carriage bolts and hex flange nuts as shown. Be sure that the plates are mounted with the flanges out as shown.
3. Locate the hitch under the vehicle with the slot in the rear flange of the side plate aligned with the center of the large hole in the vehicle frame. Place CM-SP1 inside the frame channel and secure with a 1/2" carriage bolt and flange nut as shown.
4. (1972 - 1993) Using a 17/32" drill bit, drill the vehicle frame through slotted holes on forwardmost flanges of the side plates. Drill all (4) holes as far to the outboard side of the frame rail as possible to ensure maximum strength.
(1994 - 1995) Using a 17/32" drill bit, drill the vehicle frame through slotted holes on both sides of the vehicle. Drill all (4) holes as far to the outboard side of the frame rail as possible to ensure maximum strength. Install a 1/2"-13 carriage bolt and CM-SP1 spacer into each hole and secure with a hex flange nut as shown.
5. (1972 - 1993) Add remaining fasteners.
6. Torque all 1/2" hardware to 110 ft-lbs. Torque all 7/16" hardware to 70 ft-lbs.
7. (1994 - 1995) Reinstall exhaust hanger bracket.

PERIODICALLY CHECK THIS RECEIVER HITCH TO ENSURE THAT ALL FASTENERS ARE TIGHT AND THAT ALL STRUCTURAL COMPONENTS ARE SOUND.

Curt Manufacturing Inc., warrants this product to be free of defects in material and/or workmanship at the time of retail purchase by the original purchaser. If the product is found to be defective, Curt Manufacturing Inc., may repair or replace the product, at their option, when the product is returned, prepaid, with proof of purchase. Alteration to, misuse of, or improper installation of this product voids the warranty. Curt Manufacturing Inc.'s liability is limited to repair or replacement of products found to be defective, and specifically excludes liability for incidental or consequential loss or damage.