



# 31025 INSTALLATION INSTRUCTIONS



Safety glasses should be worn at all times while installing this product.

YEARS: 2011

MAKE: FORD, MERCURY

MODEL: ESCAPE, MARINER

STYLE: SUV

**WARNING: NEVER EXCEED YOUR VEHICLE MANUFACTURER'S RECOMMENDED TOWING CAPACITY**

**WEIGHT CARRYING:**  
TRAILER WEIGHT: 3,500 LBS.  
TONGUE WEIGHT: 350 LBS.

**GROSS LOAD CAPACITY WHEN USED AS A STRAIGHT LINE PULL:**  
9,000 LBS MAX.

**INSTALLATION TIME: 40 MIN.**

THE INSTALL TIME LISTED IS FOR PROFESSIONAL INSTALLERS. IF YOU ARE HESITANT TO UNDERTAKE THIS TASK ON YOUR OWN, CONTACT AN AUTHORIZED CURT INSTALLER FOR ADDITIONAL ASSISTANCE.



**INSTALLATION REQUIRES:**

 <b>SCREW DRIVER</b>	 <b>RATCHET</b>	 <b>SOCKET EXTENSION</b>
 <b>3/4" 11/16" 10mm</b> <b>SOCKET</b>	 <b>DIE GRINDER</b>	 <b>MARKER</b>
 <b>TORQUE WRENCH</b>	 <b>SAFETY GLASSES</b>	

**INSTALLATION TIPS:**

- BEFORE YOU BEGIN INSTALLATION, READ ALL INSTRUCTIONS THOROUGHLY.
- TO EASE INSTALLATION, 2 PEOPLE MAY BE REQUIRED.
- USING PROPER TOOLS WILL GREATLY IMPROVE THE QUALITY OF THE INSTALL AND REDUCE THE TIME REQUIRED.
- NEED HELP OR HAVE SOME QUESTIONS? CALL TECHNICAL SUPPORT AT 800.798.0813

**LEVEL OF DIFFICULTY: MODERATE**

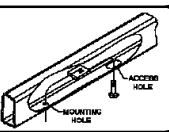
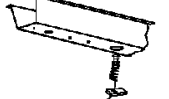
<b>EASY</b>	<b>MODERATE</b>	<b>HARD</b>
	<b>ENLARGE (2) HOLES</b>	
	<b>TRIM UNDERBODY PANELS &amp; AIR DAM</b>	
	<b>FISHWIRE HARDWARE</b>	
	<b>REVERSE FISHWIRE HARDWARE</b>	

**VEHICLE PHOTO:**



**REPRESENTATIVE PHOTO**

**HITCH ILLUSTRATION:**

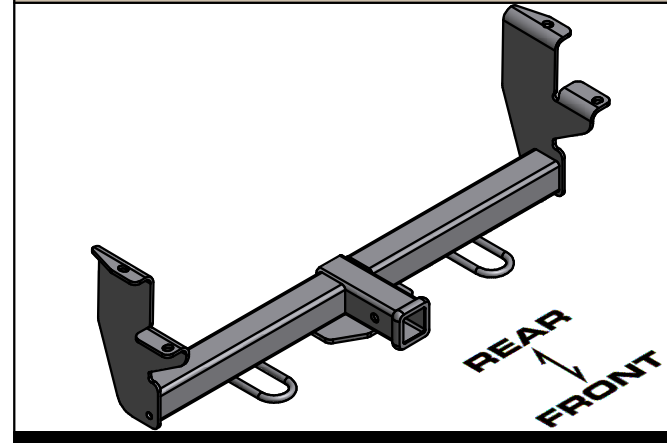

**MAKE SURE YOUR HITCH MATCHES**

**PERIODICALLY CHECK THIS RECEIVER HITCH TO ENSURE ALL FASTENERS ARE TIGHT AND ALL STRUCTURAL COMPONENTS ARE SOUND**

CURT Manufacturing Inc. warrants this product to be free of defects in material and/or workmanship at the time of retail purchase by the original purchaser. If the product is found to be defective, Curt Manufacturing Inc. may repair or replace the product at their option, when the product is returned, prepaid, with proof of purchase. Alteration to, misuse of, or improper installation of this product voids the warranty. Curt Manufacturing Inc.'s liability is limited to repair or replacement of products found to be defective, and specifically excludes liability for incidental or consequential loss or damage.

For more information log onto [www.curtmfg.com](http://www.curtmfg.com), & for helpful towing tips log onto [www.hitchinfo.com](http://www.hitchinfo.com)

# INSTALLATION WALKTHROUGH:

Parts List			
ITEM	QTY	PART NUMBER	DESCRIPTION
1	2	1/2-13 x 1 1/4	CARRIAGE BOLT
2	2	CM-SP6	.250 x 1.00 x 3.00" SQUARE HOLE SPACER
3	2	HFN 1213	HEX FLANGE NUT
4	2	7/16-14 x 1 1/4	CARRIAGE BOLT
5	2	CM-SP2	.250 x .88 x 2.25" SQUARE HOLE SPACER
6	2	7/16-14	HEX FLANGE NUT
7	2	1_2 FISHWIRE	1/2" FISHWIRE
8	2	7_16 FISHWIRE	7/16" FISHWIRE

**FISHWIRE TECHNIQUE**

INSERT COILED END OF FISHWIRE TOOL THROUGH HITCH MOUNTING HOLE IN VEHICLE FRAME RAIL AND OUT THE ACCESS HOLE. PASS COILED END OF FISHWIRE THROUGH SPACER AND THREAD BOLT INTO COIL. KINK WIRE TO KEEP SPACER SEPERATE FROM BOLT AS SHOWN. PULL FISHWIRE, SPACER, AND BOLT THROUGH FRAME AND OUT MOUNTING HOLE. USE FISHWIRE TO GUIDE HITCH DURING MOUNTING AND PREVENT LOSS OF BOLT / SPACER INSIDE FRAME RAIL.

\*\*NOTE: SOME VEHICLES MAY FISHWIRE THROUGH END OF FRAME\*\*

**ENLARGE HOLE TO REVERSE PULL 1/2" HARDWARE (BOTH SIDES)**

**REVERSE PULL FISHWIRE TECHNIQUE**

ATTACH FISHWIRE TO CARRIAGE BOLT AND SLIDE SPACER ONTO FISHWIRE. PUSH THE BOLT THRU THE HOLE FOLLOWED BY THE SPACER (AS SHOWN). PULL BOLT BACK INTO POSITION, PROTRUDING FROM THE FRAME.

1. Remove driver side under body panel by removing (6) bolts and (1) push fastener. Remove passenger side under body panel by removing (7) bolts and (1) push fastener. Remove air dam by removing (2) bolts and (5) push fasteners.



2. Enlarge access holes in frame rails to allow hardware to pass through, as shown.





## INSTALLATION WALKTHROUGH:

3. Fishwire 7/16" bolts and spacers into front support beam. Reverse fishwire 1/2" bolts and spacers into frame rails. Leave fishwires attached to bolts to prevent loosening in frame.

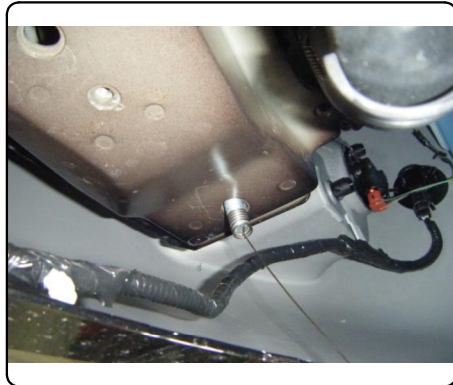

4. Test fit hitch on vehicle and trim plastic under body panels as needed to allow the hitch side plates to pass through. Trim the center of the air dam with an approximate 2.5" wide by 2.25" high notch for receiver tube clearance. Remove hitch and re-install under body panels.

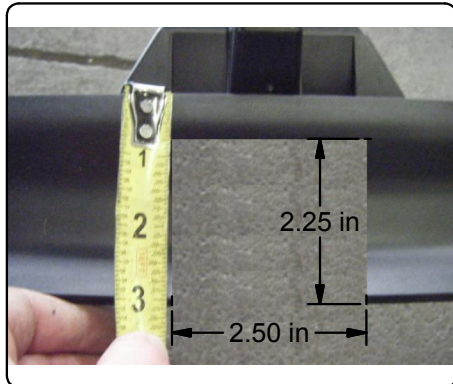

5. Raise hitch back into position and fasten with supplied nuts.



6. Torque all 7/16" fasteners to 70 ft-lbs and all 1/2" fasteners to 110 ft-lbs.

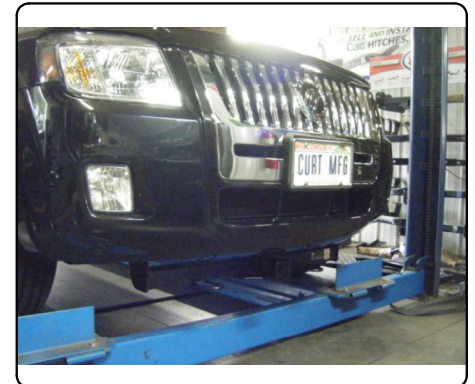

\*\*\*DO NOT EXCEED VEHICLE MANUFACTURER'S RECOMMENDED TOWING CAPACITY \*\*\*.

#### FRONT MOUNTED ACCESSORIES

- 1) Do not exceed front axle Gross Weight Rating (GAWR). Consult owners manual or specification plate located on driver's door frame. Measure gross front axle weight by placing front wheels of loaded vehicle on a scale.

**WARNING:** Exceeding GAWR may overload the front axle and/or suspension. This could result in **accident, property damage and personal injury**.

- 2) Reposition front mounted license plate if obstructed.
- 3) Do not obstruct vehicle lights.
- 4) Allow free air flow into grille opening.
- 5) Rear wheel traction may be reduced. This could effect handling. Reduce speed and drive with caution.
- 6) Accessories extend front of vehicle. This may reduce approach angle. Use caution when parking and maneuvering.
- 7) Do not obstruct driver view.

#### VEHICLE RECOVERY AND WINCHING TIPS

- 1) Use OEM tow hooks, recovery eyes or a clevis mount for attachment of a tow strap or winch cable.

**WARNING:** NEVER use a ball and/or ball mount as an anchor point for tow strap or winch cable. Severe personal injury or death could result.

- 2) Observe winch manufacturer's recommendations, cautions and warnings.
  - 3) Attach return cable to tow hook or recovery eye when using a snatch block (See figure 1).
- CAUTION:** Do not attach return cable to winch mount. This may overload winch mount and/or front mounted receiver.

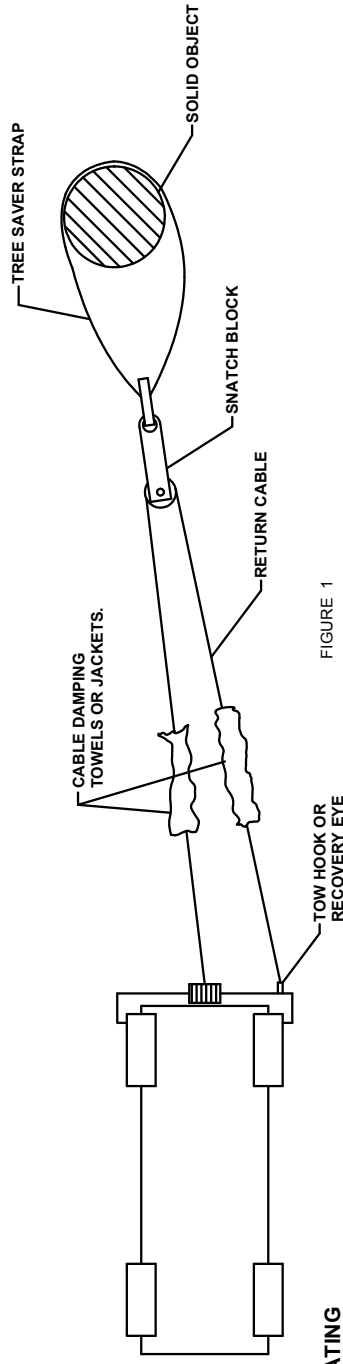

#### RATING

For **Maximum** line pull rating, winch cable must not exceed:

- 15 degree angle up or down from horizontal (See Figure 2).
- 45 degree angle left or right from straight ahead (See Figure 3).

**CAUTION:** Exceeding the maximum line pull rating may overload winch, winch mount, and/or front mounted receiver.

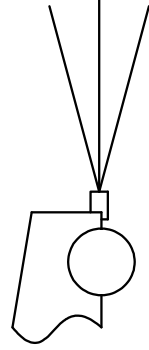

FIGURE 2

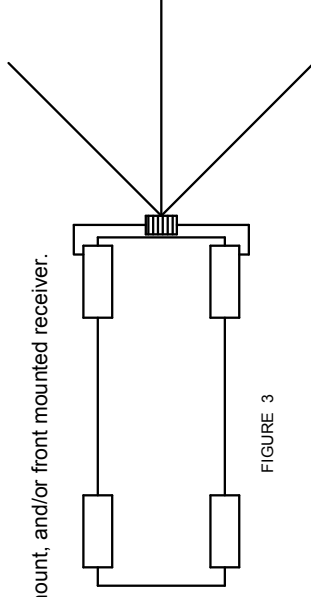

FIGURE 3

**31025****FORD ESCAPE, MERCURY MARINER**

12/7/2012

**GROSS LOAD CAPACITY WHEN USED AS A WEIGHT CARRYING HITCH: 3,500 LBS. TRAILER WEIGHT & 350 LBS. TONGUE WEIGHT.****GROSS LOAD CAPACITY WHEN USED AS A STRAIGHT LINE PULL: 9,000 LBS. MAX. LINE PULL.****\*\*\* DO NOT EXCEED VEHICLE MANUFACTURER'S RECOMMENDED TOWING CAPACITY. \*\*\*****HAVING INSTALLATION QUESTIONS? CALL TECHNICAL SUPPORT AT 1-800-798-0813**

Parts List			
ITEM	QTY	PART NUMBER	DESCRIPTION
1	2	1/2-13 x 1 1/4	CARRIAGE BOLT
2	2	CM-SP6	.250 x 1.00 x 3.00" SQUARE HOLE SPACER
3	2	HFN 1213	HEX FLANGE NUT
4	2	7/16-14 x 1 1/4	CARRIAGE BOLT
5	2	CM-SP2	.250 x .88 x 2.25" SQUARE HOLE SPACER
6	2	7/16-14	HEX FLANGE NUT
7	2	1_2 FISHWIRE	1/2" FISHWIRE
8	2	7_16 FISHWIRE	7/16" FISHWIRE

**FISHWIRE TECHNIQUE**

INSERT COILED END OF FISHWIRE TOOL THROUGH HITCH MOUNTING HOLE IN VEHICLE FRAME RAIL AND OUT THE ACCESS HOLE. PASS COILED END OF FISHWIRE THROUGH SPACER AND THREAD BOLT INTO COIL. KINK WIRE TO KEEP SPACER SEPERATE FROM BOLT AS SHOWN. PULL FISHWIRE, SPACER, AND BOLT THROUGH FRAME AND OUT MOUNTING HOLE. USE FISHWIRE TO GUIDE HITCH DURING MOUNTING AND PREVENT LOSS OF BOLT / SPACER INSIDE FRAME RAIL.

\*\*NOTE: SOME VEHICLES MAY FISHWIRE THROUGH END OF FRAME\*\*

**REVERSE PULL FISHWIRE TECHNIQUE**

ATTACH FISHWIRE TO CARRIAGE BOLT AND SLIDE SPACER ONTO FISHWIRE. PUSH THE BOLT THRU THE HOLE FOLLOWED BY THE SPACER (AS SHOWN). PULL BOLT BACK INTO POSITION, PROTRUDING FROM THE FRAME.

ENLARGE HOLE TO REVERSE PULL 1/2" HARDWARE (BOTH SIDES)

EXISTING HOLE (BOTH SIDES)

**TOOLS REQUIRED**

RATCHET  
RATCHET EXTENSION  
3/4" SOCKET  
11/16" SOCKET  
10mm SOCKET  
TORQUE WRENCH  
DREMEL TOOL / DIE GRINDER  
FLAT HEAD SCREW DRIVER

HITCH WEIGHT: 37 LBS.

**INSTALL TIME**

PROFESSIONAL: 40 MINUTES

NOVICE (DIY): 80 MINUTES

**INSTALL NOTES:**

- HOLE ENLARGEMENT REQUIRED
- TRIM UNDERBODY PANELS
- FISHWIRING REQUIRED

**INSTALLATION STEPS**

1. Remove driver side under body panel by removing (6) bolts and (1) push fastener. Remove passenger side under body panel by removing (7) bolts and (1) push fastener. Remove air dam by removing (2) bolts and (5) push fasteners.
2. Enlarge access holes in frame rails to allow hardware to pass through, as shown above.
3. Fishwire 7/16" bolts and spacers into front support beam. Reverse fishwire 1/2" bolts and spacers into frame rails, as shown above. Leave fishwires attached to bolts to prevent loosing in frame.
4. Test fit hitch on vehicle and trim plastic under body panels as needed to allow the hitch side plates to pass through. Trim the center of the air dam with an approximate 2.5" wide by 2.25" high notch for receiver tube clearance. Remove hitch and re-install under body panels.
5. Raise hitch back into position and fasten with supplied nuts.
6. Torque all 7/16" fasteners to 70 ft-lbs and all 1/2" fasteners to 110 ft-lbs.

**PERIODICALLY CHECK THIS RECEIVER HITCH TO ENSURE THAT ALL FASTENERS ARE TIGHT AND THAT ALL STRUCTURAL COMPONENTS ARE SOUND.**

Curt Manufacturing Inc., warrants this product to be free of defects in material and/or workmanship at the time of retail purchase by the original purchaser. If the product is found to be defective, Curt Manufacturing Inc., may repair or replace the product, at their option, when the product is returned, prepaid, with proof of purchase. Alteration to, misuse of, or improper installation of this product voids the warranty. Curt Manufacturing Inc.'s liability is limited to repair or replacement of products found to be defective, and specifically excludes liability for incidental or consequential loss or damage.

\*\*\***DO NOT EXCEED VEHICLE MANUFACTURER'S RECOMMENDED TOWING CAPACITY**\*\*\*.

### FRONT MOUNTED ACCESSORIES

1) Do not exceed front axle Gross Weight Rating (GAWR). Consult owners manual or specification plate located on driver's door frame. Measure gross front axle weight by placing front wheels of loaded vehicle on a scale.

**WARNING:** Exceeding GAWR may overload the front axle and/or suspension. This could result in **accident, property damage and personal injury.**

- 2) Reposition front mounted license plate if obstructed.
- 3) Do not obstruct vehicle lights.
- 4) Allow free air flow into grille opening.
- 5) Rear wheel traction may be reduced. This could effect handling. Reduce speed and drive with caution.
- 6) Accessories extend front of vehicle. This may reduce approach angle. Use caution when parking and maneuvering.
- 7) Do not obstruct driver view.

### VEHICLE RECOVERY AND WINCHING TIPS

1) Use OEM tow hooks, recovery eyes or a clevis mount for attachment of a tow strap or winch cable.

**WARNING: NEVER** use a ball and/or ball mount as an anchor point for tow strap or winch cable. Severe personal injury or death could result.

- 2) Observe winch manufacturer's recommendations, cautions and warnings.
- 3) Attach return cable to tow hook or recovery eye when using a snatch block (See figure 1).

**CAUTION:** Do not attach return cable to winch mount. This may overload winch mount and/or front mounted receiver.

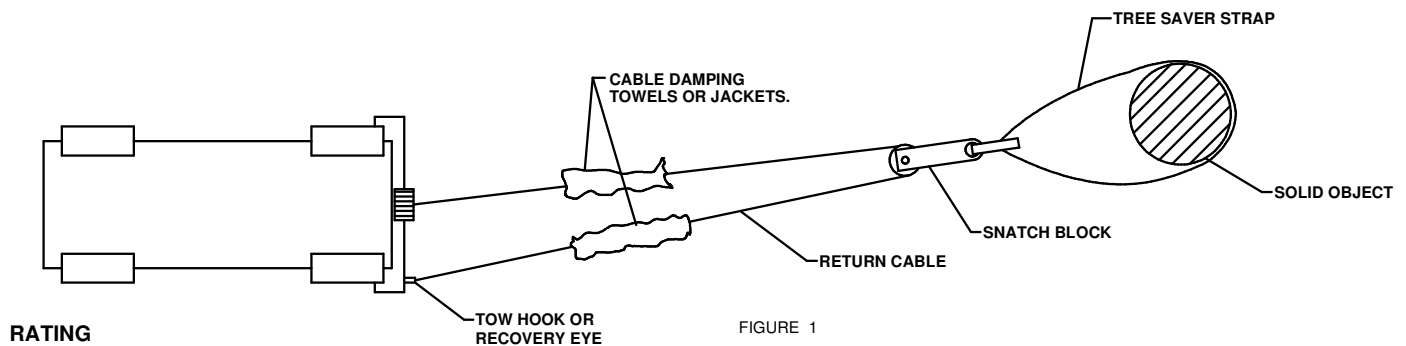

### RATING

For **Maximum** line pull rating, winch cable must not exceed:

- 15 degree angle up or down from horizontal (See Figure 2).
- 45 degree angle left or right from straight ahead (See Figure 3).

**CAUTION:** Exceeding the maximum line pull rating may over load winch, winch mount, and/or front mounted receiver.

