



Safety glasses should be worn at all times while installing this product.

YEARS: 2011-PRESENT

MAKE: FORD

MODEL: EDGE

STYLE: CROSSOVER

**WARNING: NEVER EXCEED YOUR VEHICLE MANUFACTURER'S RECOMMENDED TOWING CAPACITY**

**WEIGHT CARRYING:**  
 TRAILER WEIGHT: 3,500 LBS.  
 TONGUE WEIGHT: 350 LBS.

**GROSS LOAD CAPACITY WHEN USED AS A STRAIGHT LINE PULL:**  
 9,000 LBS MAX.

**INSTALLATION TIME: 30 MIN.**

THE INSTALL TIME LISTED IS FOR PROFESSIONAL INSTALLERS. IF YOU ARE HESITANT TO UNDERTAKE THIS TASK ON YOUR OWN, CONTACT AN AUTHORIZED CURT INSTALLER FOR ADDITIONAL ASSISTANCE.

**INSTALLATION REQUIRES:**

<b>RATCHET</b>	<b>SOCKET</b> 3/4" 5/8"	<b>BOXED END WRENCH</b> 5/8"
<b>MARKER</b>	<b>TAPE MEASURE</b>	<b>DIE GRINDER</b>
<b>TORQUE WRENCH</b>	<b>SAFETY GLASSES</b>	

**INSTALLATION TIPS:**

- BEFORE YOU BEGIN INSTALLATION, READ ALL INSTRUCTIONS THOROUGHLY.
- TO EASE INSTALLATION, 2 PEOPLE MAY BE REQUIRED.
- USING PROPER TOOLS WILL GREATLY IMPROVE THE QUALITY OF THE INSTALL AND REDUCE THE TIME REQUIRED.
- NEED HELP OR HAVE SOME QUESTIONS? CALL TECHNICAL SUPPORT AT 800.798.0813

**LEVEL OF DIFFICULTY: MODERATE**

EASY	MODERATE	HARD
	OPTIONAL AIR DAM TRIMMING	
	HOLE ENLARGMENT REQUIRED	
	FISHWIRE HARDWARE	
	REVERSE FISHWIRE HARDWARE	

**VEHICLE PHOTO:**



REPRESENTATIVE PHOTO

**HITCH ILLUSTRATION:**

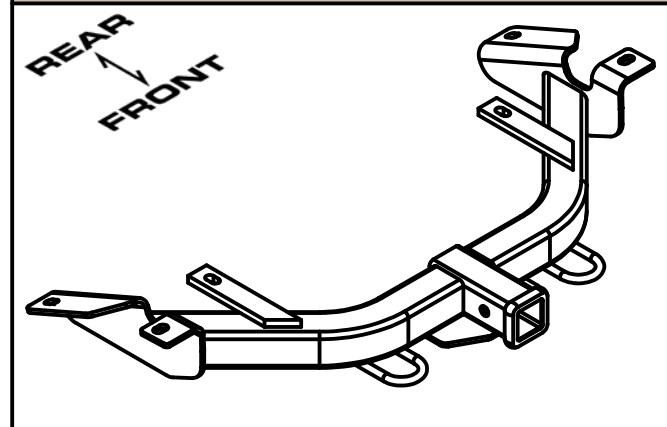

MAKE SURE YOUR HITCH MATCHES

**PERIODICALLY CHECK THIS RECEIVER HITCH TO ENSURE ALL FASTENERS ARE TIGHT AND ALL STRUCTURAL COMPONENTS ARE SOUND**

CURT Manufacturing Inc. warrants this product to be free of defects in material and/or workmanship at the time of retail purchase by the original purchaser. If the product is found to be defective, Curt Manufacturing Inc. may repair or replace the product at their option, when the product is returned, prepaid, with proof of purchase. Alteration to, misuse of, or improper installation of this product voids the warranty. Curt Manufacturing Inc.'s liability is limited to repair or replacement of products found to be defective, and specifically excludes liability for incidental or consequential loss or damage.

For more information log onto [www.curtmfg.com](http://www.curtmfg.com), & for helpful towing tips log onto [www.hitchinfo.com](http://www.hitchinfo.com)

# INSTALLATION WALKTHROUGH:

Parts List			
ITEM	QTY	PART NUMBER	DESCRIPTION
1	4	1/2-13 x 1 1/2	CARRIAGE BOLT
2	2	CM-SP6	.250 x 1.00 x 3.00" SQUARE HOLE SPACER
3	2	CM-SP12	.250 x 1.00 x 2.00" SQUARE HOLE SPACER
4	4	HFN 1213	HEX FLANGE NUT
5	2	1_2 FISHWIRE	1/2" FISHWIRE
6	2	7/16	WASHER
7	2	7/16-14	HEX FLANGE NUT
8	2	7_16 - 14 x 3 1_2	HEX BOLT

### FISHWIRE TECHNIQUE

INSERT COILED END OF FISHWIRE TOOL THROUGH HITCH MOUNTING HOLE IN VEHICLE FRAME RAIL AND OUT THE ACCESS HOLE. PASS COILED END OF FISHWIRE THROUGH SPACER AND THREAD BOLT INTO COIL. KINK WIRE TO KEEP SPACER SEPARATE FROM BOLT AS SHOWN. PULL FISHWIRE, SPACER, AND BOLT THROUGH FRAME AND OUT MOUNTING HOLE. USE FISHWIRE TO GUIDE HITCH DURING MOUNTING AND PREVENT LOSS OF BOLT / SPACER INSIDE FRAME RAIL.

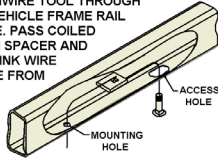

### REVERSE PULL FISHWIRE TECHNIQUE

ATTACH FISHWIRE TO CARRIAGE BOLT AND SLIDE SPACER ONTO FISHWIRE. PUSH THE BOLT THRU THE HOLE FOLLOWED BY THE SPACER (AS SHOWN). PULL BOLT BACK INTO POSITION, PROTRUDING FROM THE FRAME.

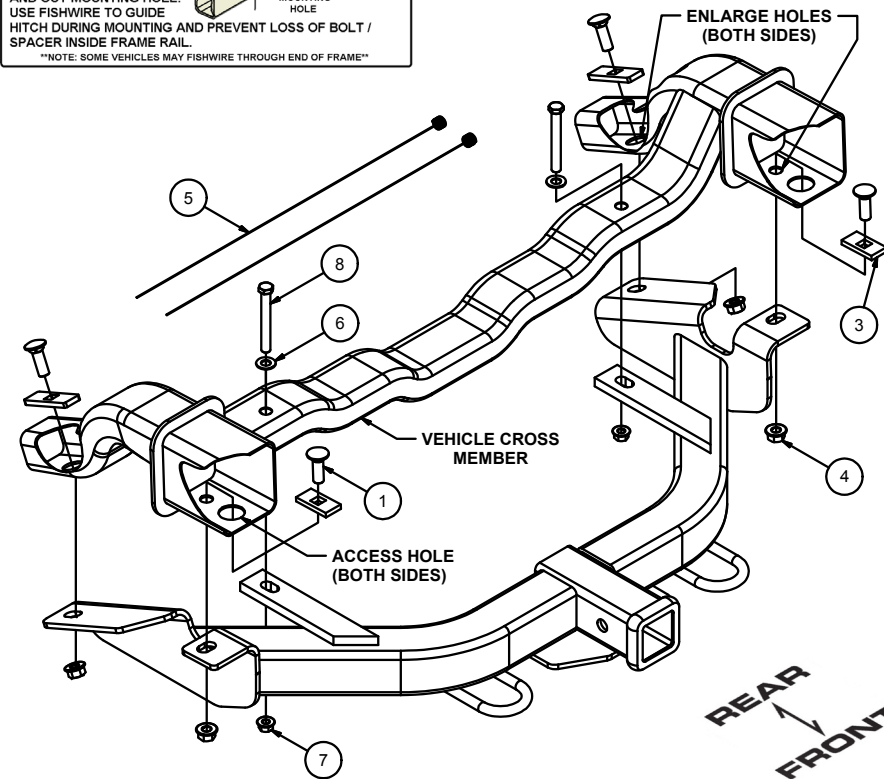
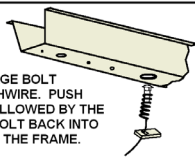

1. Trim air dam or remove and return air dam to vehicle owner. See TRIM DIAGRAM below.



### TRIM DIAGRAM

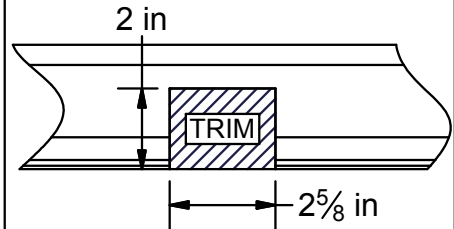

**NOTE:** TRIM DIMENSIONS ARE APPROXIMATE

2. Enlarge (2) front mounting holes on vehicle frame rails to allow 1/2" carriage bolts to pass through. Fishwire (2) 1/2" carriage bolts and (2) CM-SP12 spacers through access holes into enlarged holes. See FISHWIRE TECHNIQUE.

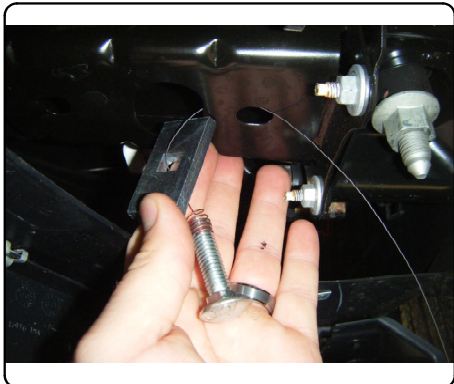
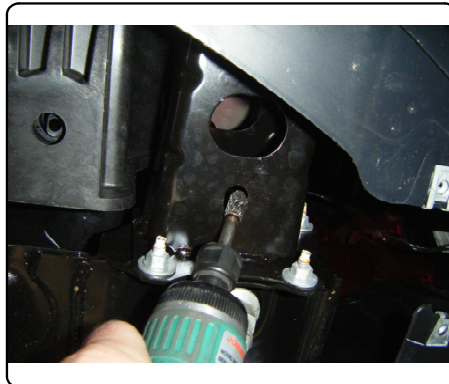

## INSTALLATION WALKTHROUGH:

3. Insert (2) 7/16" hex bolts with a 7/16" washer through the top of vehicle cross member in mounting locations.



4. Enlarge (2) rear mounting holes on vehicle frame rails to allow 1/2" carriage bolt and CM-SP6 spacer to pass through.

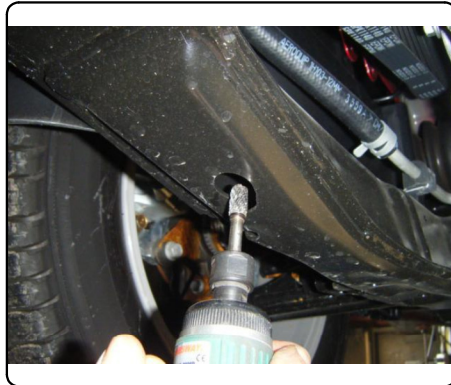
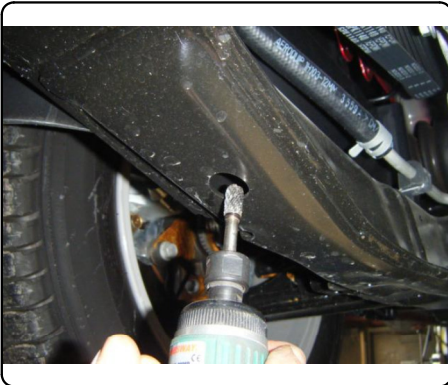

5. Reverse fishwire (2) 1/2" carriage bolts and (2) CM-SP6 spacers into position through the holes enlarged in step 4. See REVERSE PULL FISHWIRE TECHNIQUE on page 2.

**NOTE:** Leave fishwires attached to this hardware to prevent loss in frame.



6. Thread fishwires through the correct mounting holes on hitch and raise hitch into position. Secure hitch to the vehicle with (4) 1/2" flange nuts and (2) 7/16" flange nuts. First torque front 1/2" hardware to 75 ft-lbs, second torque rear 1/2" hardware to 75 ft-lbs and third torque 7/16" hardware to 50 ft-lbs.



31050

FORD EDGE

12/9/2010

GROSS LOAD CAPACITY WHEN USED AS A WEIGHT CARRYING HITCH: 3,500 LBS. TRAILER WEIGHT & 350 LBS. TONGUE WEIGHT.  
 GROSS LOAD CAPACITY WHEN USED AS A STRAIGHT LINE PULL: 9,000 LBS. MAX. LINE PULL.  
 \*\*\* DO NOT EXCEED VEHICLE MANUFACTURER'S RECOMMENDED TOWING CAPACITY. \*\*\*  
 HAVING INSTALLATION QUESTIONS? CALL TECHNICAL SUPPORT AT 1-800-798-0813

Parts List			
ITEM	QTY	PART NUMBER	DESCRIPTION
1	4	1/2-13 x 1 1/2	CARRIAGE BOLT
2	2	CM-SP6	.250 x 1.00 x 3.00" SQUARE HOLE SPACER
3	2	CM-SP12	.250 x 1.00 x 2.00" SQUARE HOLE SPACER
4	4	HFN 1213	HEX FLANGE NUT
5	2	7/16	WASHER
6	2	7_16 - 14 x 3 1_2	HEX BOLT
7	2	7/16-14	HEX FLANGE NUT
8	2	1_2 FISHWIRE	1/2" FISHWIRE

TOOLS REQUIRED
RATCHET
3/4" & 5/8" SOCKETS
5/8" BOXED END WRENCH
DIE GRINDER
TAPE MEASURE
MARKER
TORQUE WRENCH

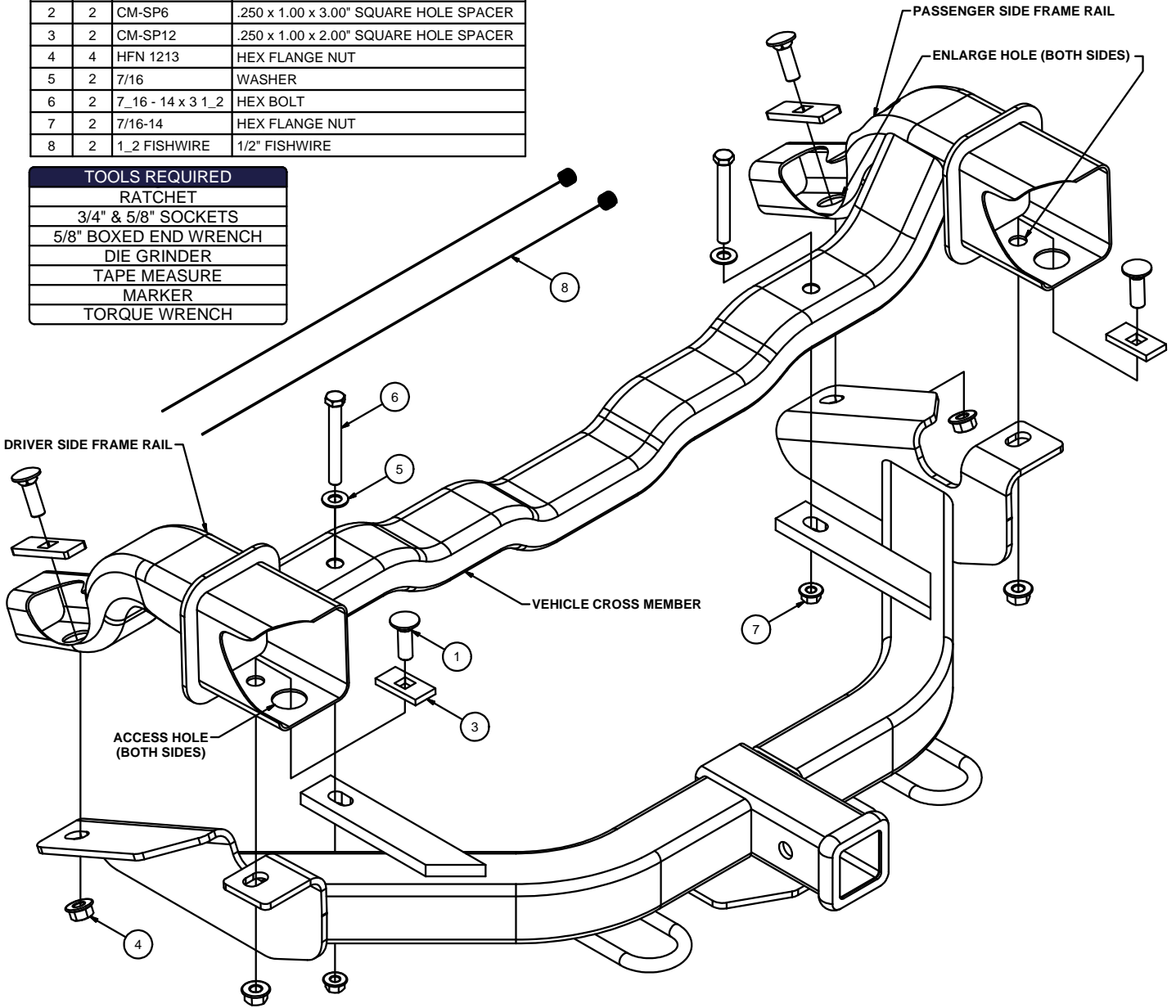

HITCH WEIGHT: .39 LBS.  
 INSTALL TIME  
 PROFESSIONAL: 30 MINUTES  
 NOVICE (DIY): 60 MINUTES  
 INSTALL NOTES:  
 - HOLE ENLARGEMENT REQUIRED  
 - OPTIONAL AIR DAM TRIMMING  
 - FISHWIRE HARDWARE

PERIODICALLY CHECK THIS RECEIVER HITCH TO ENSURE THAT ALL FASTENERS ARE TIGHT AND THAT ALL STRUCTURAL COMPONENTS ARE SOUND.

Curt Manufacturing Inc., warrants this product to be free of defects in material and/or workmanship at the time of retail purchase by the original purchaser. If the product is found to be defective, Curt Manufacturing Inc., may repair or replace the product, at their option, when the product is returned, prepaid, with proof of purchase. Alteration to, misuse of, or improper installation of this product voids the warranty. Curt Manufacturing Inc.'s liability is limited to repair or replacement of products found to be defective, and specifically excludes liability for incidental or consequential loss or damage.

**31050**

**FORD EDGE**

12/9/2010

GROSS LOAD CAPACITY WHEN USED AS A WEIGHT CARRYING HITCH: 3,500 LBS. TRAILER WEIGHT & 350 LBS. TONGUE WEIGHT.  
GROSS LOAD CAPACITY WHEN USED AS A STRAIGHT LINE PULL: 9,000 LBS. MAX. LINE PULL.  
\*\*\* DO NOT EXCEED VEHICLE MANUFACTURER'S RECOMMENDED TOWING CAPACITY. \*\*\*  
HAVING INSTALLATION QUESTIONS? CALL TECHNICAL SUPPORT AT 1-800-798-0813

**FISHWIRE TECHNIQUE**

INSERT COILED END OF FISHWIRE TOOL THROUGH HITCH MOUNTING HOLE IN VEHICLE FRAME RAIL AND OUT THE ACCESS HOLE. PASS COILED END OF FISHWIRE THROUGH SPACER AND THREAD BOLT INTO COIL. KINK WIRE TO KEEP SPACER SEPARATE FROM BOLT AS SHOWN. PULL FISHWIRE, SPACER, AND BOLT THROUGH FRAME AND OUT MOUNTING HOLE. USE FISHWIRE TO GUIDE HITCH DURING MOUNTING AND PREVENT LOSS OF BOLT / SPACER INSIDE FRAME RAIL.

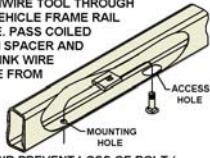

\*\*\*NOTE: SOME VEHICLES MAY FISHWIRE THROUGH END OF FRAME\*\*

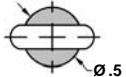

HOLE ENLARGEMENT DIAGRAM

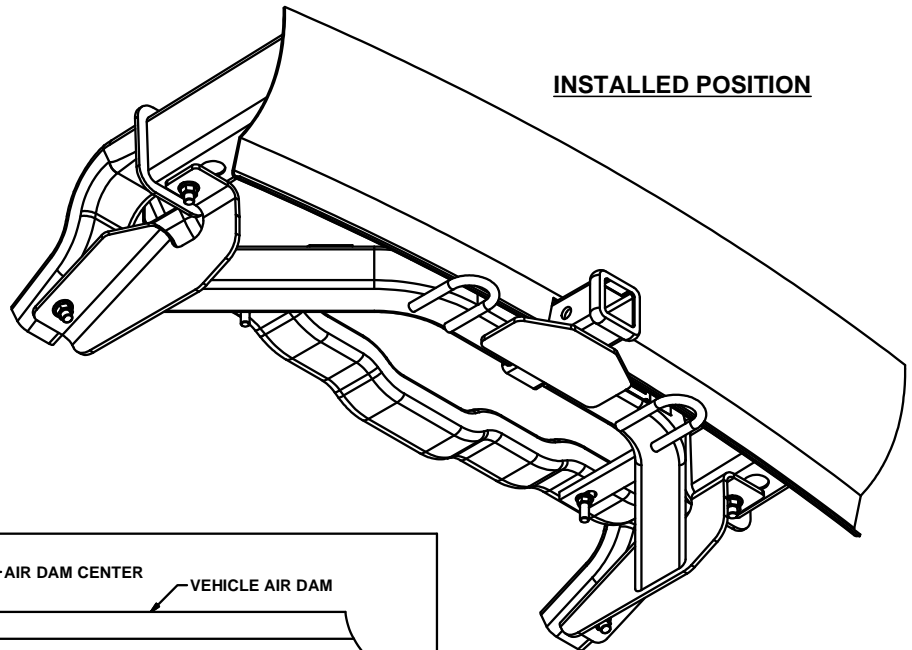

INSTALLED POSITION

**TRIM DIAGRAM**

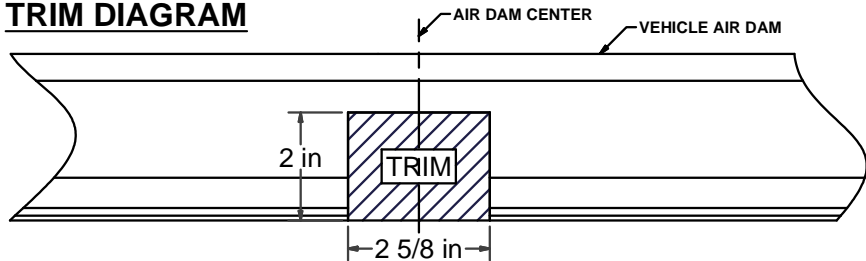

**Note:** Trim dimensions are approximate.

**REVERSE PULL FISHWIRE TECHNIQUE**

ATTACH FISHWIRE TO CARRIAGE BOLT AND SLIDE SPACER ONTO FISHWIRE. PUSH THE BOLT THRU THE HOLE FOLLOWED BY THE SPACER (AS SHOWN). PULL BOLT BACK INTO POSITION, PROTRUDING FROM THE FRAME.

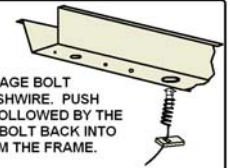

**INSTALLATION STEPS**

1. Trim air dam or remove and return air dam to vehicle owner. See TRIM DIAGRAM above.
  2. Enlarge (2) front mounting holes on vehicle frame rails to allow 1/2" carriage bolts to pass through.
  3. Fishwire (2) 1/2" carriage bolts and (2) CM-SP12 spacers through access holes into the holes enlarged in step 2. See FISHWIRE TECHNIQUE above.
  4. Insert (2) 7/16" hex bolts with a 7/16" washer through the top of vehicle cross member in mounting locations.
  5. Enlarge (2) rear mounting holes on vehicle frame rails to allow 1/2" carriage bolt and CM-SP6 spacer to pass through.
  6. Reverse fishwire (2) 1/2" carriage bolts and (2) CM-SP6 spacers into position through the holes enlarged in step 5. See REVERSE PULL FISHWIRE TECHNIQUE above.
- NOTE:** Leave fishwires attached to this hardware to prevent loss in frame.
7. Thread fishwires through the correct mounting holes on hitch and raise hitch into position. Secure hitch to the vehicle with (4) 1/2" flange nuts and (2) 7/16" flange nuts.
  8. First torque front 1/2" hardware to 75 ft-lbs, second torque rear 1/2" hardware to 75 ft-lbs and third torque 7/16" hardware to 50 ft-lbs.

**PERIODICALLY CHECK THIS RECEIVER HITCH TO ENSURE THAT ALL FASTENERS ARE TIGHT AND THAT ALL STRUCTURAL COMPONENTS ARE SOUND.**

Curt Manufacturing Inc., warrants this product to be free of defects in material and/or workmanship at the time of retail purchase by the original purchaser. If the product is found to be defective, Curt Manufacturing Inc., may repair or replace the product, at their option, when the product is returned, prepaid, with proof of purchase. Alteration to, misuse of, or improper installation of this product voids the warranty. Curt Manufacturing Inc.'s liability is limited to repair or replacement of products found to be defective, and specifically excludes liability for incidental or consequential loss or damage.

**\*\*\*DO NOT EXCEED VEHICLE MANUFACTURER'S RECOMMENDED TOWING CAPACITY \*\*\*.**

### FRONT MOUNTED ACCESSORIES

1) Do not exceed front axle Gross Weight Rating (GAWR). Consult owners manual or specification plate located on driver's door frame. Measure gross front axle weight by placing front wheels of loaded vehicle on a scale.

**WARNING:** Exceeding GAWR may overload the front axle and/or suspension. This could result in **accident, property damage and personal injury.**

- 2) Reposition front mounted license plate if obstructed.
- 3) Do not obstruct vehicle lights.
- 4) Allow free air flow into grille opening.
- 5) Rear wheel traction may be reduced. This could effect handling. Reduce speed and drive with caution.
- 6) Accessories extend front of vehicle. This may reduce approach angle. Use caution when parking and maneuvering.
- 7) Do not obstruct driver view.

### VEHICLE RECOVERY AND WINCHING TIPS

1) Use OEM tow hooks, recovery eyes or a clevis mount for attachment of a tow strap or winch cable.

**WARNING: NEVER** use a ball and/or ball mount as an anchor point for tow strap or winch cable. Severe personal injury or death could result.

- 2) Observe winch manufacturer's recommendations, cautions and warnings.
- 3) Attach return cable to tow hook or recovery eye when using a snatch block (See figure 1).

**CAUTION:** Do not attach return cable to winch mount. This may overload winch mount and/or front mounted receiver.

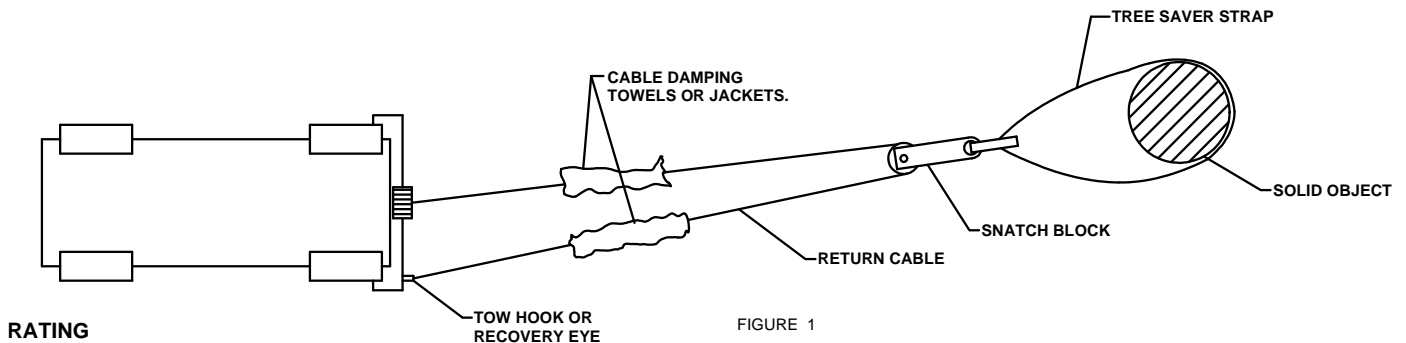

### RATING

For **Maximum** line pull rating, winch cable must not exceed:

- 15 degree angle up or down from horizontal (See Figure 2).
- 45 degree angle left or right from straight ahead (See Figure 3).

**CAUTION:** Exceeding the maximum line pull rating may over load winch, winch mount, and/or front mounted receiver.

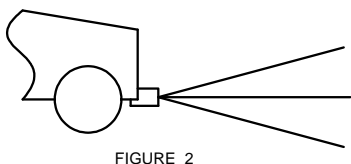

FIGURE 2

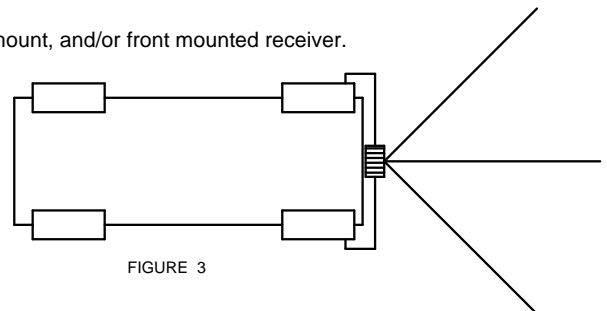

FIGURE 3