

31230

# DODGE DAKOTA / MITSUBISHI RAIDER

11/26/2012

PAGE 1 OF 3

GROSS LOAD CAPACITY WHEN USED AS A WEIGHT CARRYING HITCH: 3,500 LBS. TRAILER WEIGHT & 350 LBS. TONGUE WEIGHT.

GROSS LOAD CAPACITY WHEN USED AS A STRAIGHT LINE PULL: 9,000 LBS. MAX. LINE PULL.

**\*\*\* DO NOT EXCEED VEHICLE MANUFACTURER'S RECOMMENDED TOWING CAPACITY. \*\*\***

HAVING INSTALLATION QUESTIONS? CALL TECHNICAL SUPPORT AT 1-800-798-0813

### Parts List

ITEM	QTY	PART NUMBER	DESCRIPTION
1	4	HFN 1213	HEX FLANGE NUT
2	4	1_2 - 13 x 6	CARRIAGE BOLT (FULL THREAD)
3	4	CM-31230-SP	.706 OD x .622 ID, SPACER
4	2	CM-31230-BP	2.00" X .250" BOLT PLATE

### TOOLS REQUIRED

SOCKET WRENCH

19mm SOCKET

3/4" SOCKET

6" SOCKET EXTENSION

TORQUE WRENCH

ROTARY TOOL

CUTOFF WHEEL

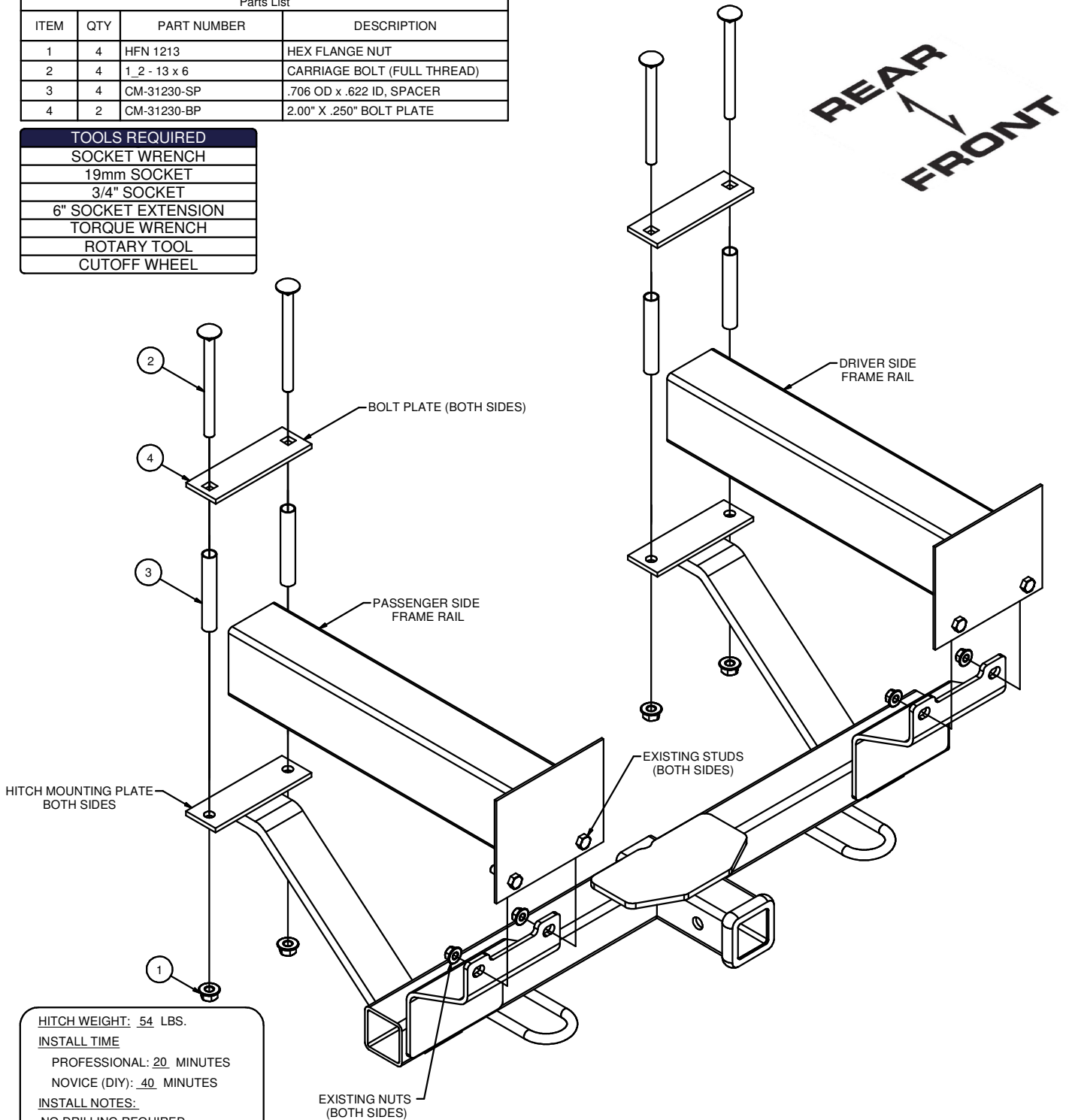

HITCH WEIGHT: 54 LBS.

### INSTALL TIME

PROFESSIONAL: 20 MINUTES

NOVICE (DIY): 40 MINUTES

### INSTALL NOTES:

-NO DRILLING REQUIRED

-REMOVE EXISTING HARDWARE

-FASCIA TRIMMING

**PERIODICALLY CHECK THIS RECEIVER HITCH TO ENSURE THAT ALL FASTENERS ARE TIGHT AND THAT ALL STRUCTURAL COMPONENTS ARE SOUND.**

Curt Manufacturing Inc., warrants this product to be free of defects in material and/or workmanship at the time of retail purchase by the original purchaser. If the product is found to be defective, Curt Manufacturing Inc., may repair or replace the product, at their option, when the product is returned, prepaid, with proof of purchase. Alteration to, misuse of, or improper installation of this product voids the warranty. Curt Manufacturing Inc.'s liability is limited to repair or replacement of products found to be defective, and specifically excludes liability for incidental or consequential loss or damage.

31230

## DODGE DAKOTA / MITSUBISHI RAIDER

11/26/2012

GROSS LOAD CAPACITY WHEN USED AS A WEIGHT CARRYING HITCH: 3,500 LBS. TRAILER WEIGHT & 350 LBS. TONGUE WEIGHT.

GROSS LOAD CAPACITY WHEN USED AS A STRAIGHT LINE PULL: 9,000 LBS. MAX. LINE PULL.

**\*\*\* DO NOT EXCEED VEHICLE MANUFACTURER'S RECOMMENDED TOWING CAPACITY. \*\*\***

HAVING INSTALLATION QUESTIONS? CALL TECHNICAL SUPPORT AT 1-800-798-0813

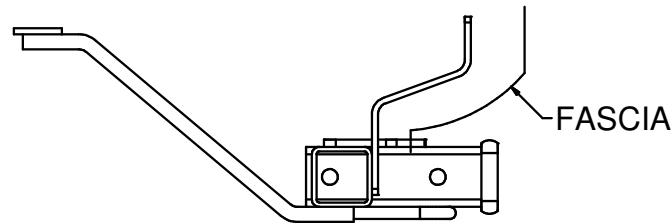

INSTALLED HITCH POSITION

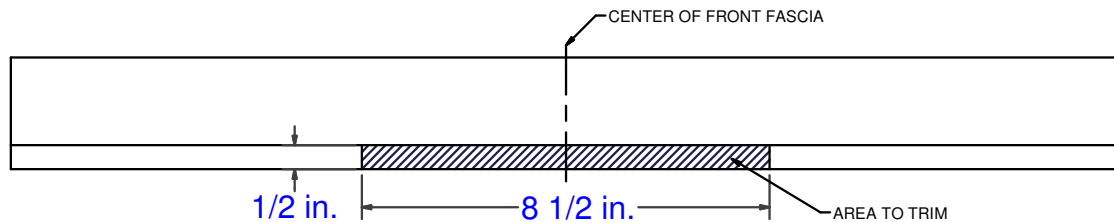

FASCIA TRIM DIAGRAM

### INSTALLATION STEPS

1. Mark and trim fascia according to FASCIA TRIM DIAGRAM, **if desired**. Installed hitch will push up on fascia slightly if trimming is not performed.
2. Remove four (4) existing bumper nuts (two per side) from the bottom bumper attachment studs. Save nuts for use in Step 5.
3. If present, remove factory tow hooks and return to owner.
4. Raise hitch into position over existing studs from Step 2.
5. Secure hitch with nuts removed in Step 2.
6. Insert two (2) 1/2-13 carriage bolts through each bolt plate and place bolt plates with carriage bolts over frame rails.
7. Place tube spacers between bolt plates and hitch, as shown.
8. Insert carriage bolts through hitch mounting plates.
9. Secure carriage bolts with 1/2-13 hex flange nuts.
10. Torque 1/2 in. hardware to 110 lb-ft and factory hardware to 45 lb-ft.

**PERIODICALLY CHECK THIS RECEIVER HITCH TO ENSURE THAT ALL FASTENERS ARE TIGHT AND THAT ALL STRUCTURAL COMPONENTS ARE SOUND.**

Curt Manufacturing Inc., warrants this product to be free of defects in material and/or workmanship at the time of retail purchase by the original purchaser. If the product is found to be defective, Curt Manufacturing Inc., may repair or replace the product, at their option, when the product is returned, prepaid, with proof of purchase. Alteration to, misuse of, or improper installation of this product voids the warranty. Curt Manufacturing Inc.'s liability is limited to repair or replacement of products found to be defective, and specifically excludes liability for incidental or consequential loss or damage.

# 31230

**\*\*\*DO NOT EXCEED VEHICLE MANUFACTURER'S RECOMMENDED TOWING CAPACITY \*\*\*.**

## FRONT MOUNTED ACCESSORIES

1) Do not exceed front axle Gross Weight Rating (GAWR). Consult owners manual or specification plate located on driver's door frame. Measure gross front axle weight by placing front wheels of loaded vehicle on a scale.

**WARNING:** Exceeding GAWR may overload the front axle and/or suspension. This could result in **accident, property damage and personal injury.**

- 2) Reposition front mounted license plate if obstructed.
- 3) Do not obstruct vehicle lights.
- 4) Allow free air flow into grille opening.
- 5) Rear wheel traction may be reduced. This could effect handling. Reduce speed and drive with caution.
- 6) Accessories extend front of vehicle. This may reduce approach angle. Use caution when parking and maneuvering.
- 7) Do not obstruct driver view.

## VEHICLE RECOVERY AND WINCHING TIPS

1) Use OEM tow hooks, recovery eyes or a clevis mount for attachment of a tow strap or winch cable.

**WARNING: NEVER** use a ball and/or ball mount as an anchor point for tow strap or winch cable. Severe personal injury or death could result.

- 2) Observe winch manufacturer's recommendations, cautions and warnings.
- 3) Attach return cable to tow hook or recovery eye when using a snatch block (See figure 1).

**CAUTION:** Do not attach return cable to winch mount. This may overload winch mount and/or front mounted receiver.

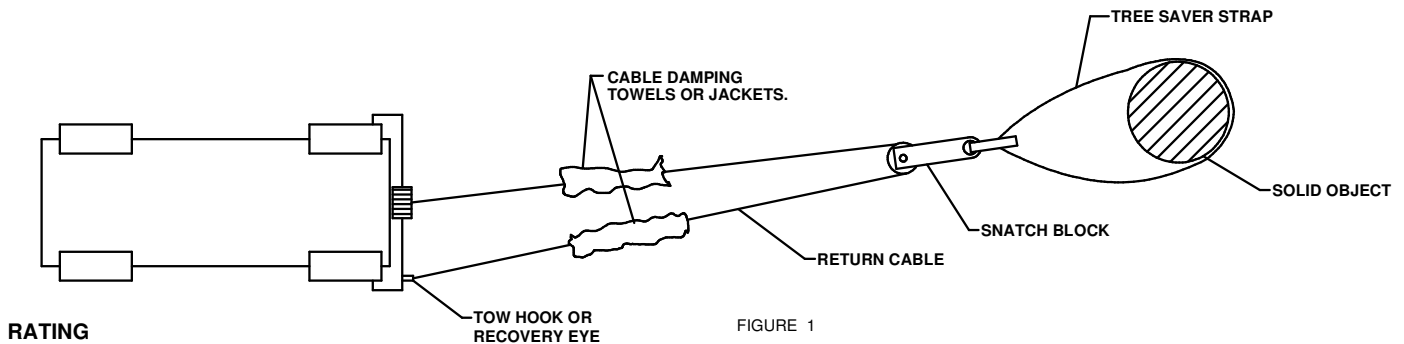

For **Maximum** line pull rating, winch cable must not exceed:  
- 15 degree angle up or down from horizontal (See Figure 2).  
- 45 degree angle left or right from straight ahead (See Figure 3).

**CAUTION:** Exceeding the maximum line pull rating may over load winch, winch mount, and/or front mounted receiver.

