

INSTALLATION MANUAL

70106

Level of Difficulty

Moderate

Installed Attachment Tabs

Height	17-1/2"
Width	35"

Parts List

Item	Qty	Description
1	1	Tow bar base plate, driver
2	1	Tow bar base plate, passenger
3	2	Tow bar mounting tab
4	2	Safety cable, 7,500 lbs.
5	8	Square hole spacer, 1/4" x 1" x 2-1/2"
6	8	Carriage bolt, 1/2"-13 x 2", grade 8
7	8	Flange nut, 1/2"-13, grade 8
8	4	Quick link, 1/4"
9	2	Socket plug

Tools Required

Torque wrench	Drill
Socket, 3/4"	Drill bit, 17/32"
Socket, 7/16"	T30 Torx bit
Socket, 8mm	Wrench, 7/16"
Socket, 10mm	Wrench, 3/4"
Socket, 15mm	Tape measure
Socket, 21mm	Fishwire, 1/2" (includes four)

⚠ WARNING

Never exceed the vehicle manufacturer's recommended gross vehicle weight rating (GVWR).

Product Photo



Not pictured: Safety cables, quick links and socket plugs

⚠ CAUTION

Take care when cutting any plastic or metal as injury may occur if done improperly.

NOTICE

Before you begin installation, read all instructions thoroughly.

Proper tools will improve the quality of installation and reduce the time required.

This installation requires the front bumper to be removed and reinstalled. Some drilling and trimming are required.

To help prevent damage to the product or vehicle, refer to the specified torque specifications when securing hardware during the installation process.

If equipped, we recommend removing the base plate attachment tabs when not in use.

Torque Specifications

	Bolt Size	CL8.8	CL10.9		Bolt Size	Grade 5	Grade 8
	Metric	M6 bolt	6.6 ft-lbs.		9.4 ft-lbs.	SAE	1/4" bolt
M8 bolt		16.0 ft-lbs.	22.9 ft-lbs.	5/16" bolt	178 in-lbs.		251 in-lbs.
M10 bolt		31.6 ft-lbs.	45.2 ft-lbs.	3/8" bolt	26 ft-lbs.		37 ft-lbs.
M12 bolt		55.1 ft-lbs.	78.9 ft-lbs.	7/16" bolt	42 ft-lbs.		59 ft-lbs.
M14 bolt		88.1 ft-lbs.	126.1 ft-lbs.	1/2" bolt	75 ft-lbs.		110 ft-lbs.
M16 bolt		136.7 ft-lbs.	195.6 ft-lbs.	5/8" bolt	128 ft-lbs.		180 ft-lbs.
M18 bolt		195.4 ft-lbs.	270.3 ft-lbs.	3/4" bolt	227 ft-lbs.		320 ft-lbs.

Use above torque setting unless otherwise noted

ASSEMBLY

Parts List

Item	Qty	Description
1	1	Tow bar base plate, driver
2	1	Tow bar base plate, passenger
3	2	Tow bar mounting tab
4	2	Safety cable, 7,500 lbs.
5	8	Square hole spacer, 1/4" x 1" x 2-1/2"
6	8	Carriage bolt, 1/2"-13 x 2", grade 8
7	8	Flange nut, 1/2"-13, grade 8
8	4	Quick link, 1/4"
9	2	Socket plug

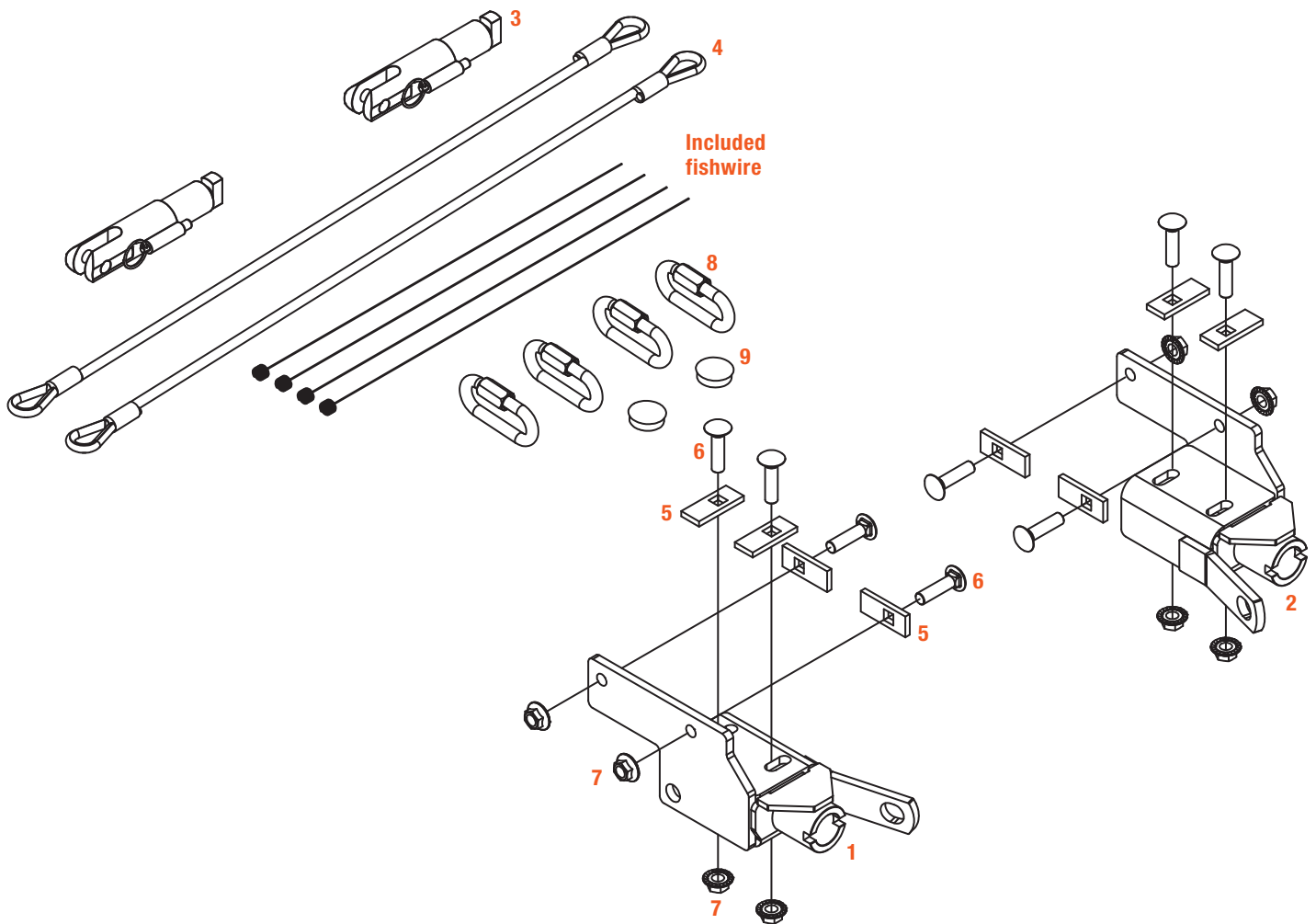

BUMPER REMOVAL

2009-2014 F-150

Step 1

Use a 15mm socket to remove the nut in front of the lower valance under the tow hooks.

Repeat on the other side of the vehicle.

Step 2

Use a 21mm socket to remove the two nuts on the backside of the bumper on either side of the tow hook.

Repeat on the other side of the vehicle.

Step 3

Open the hood and unclip the hood release cable on the passenger side. Then, use an 8mm socket to remove the two bolts near the center of the bumper.

Use a 10mm socket to remove the bolt at the very center of the bumper. Carefully remove the bumper, unplugging any wiring harnesses as needed. Carefully remove the bumper and set it aside so it will not be damaged during the rest of the installation.

Skip to Step 12.

2015-2018 F-150

Step 4

Using a non-marring pry tool, remove the plastic cover insert and license plate holder from the bumper and set it aside.



2015-2018 F-150 (CONTINUED)

Step 5

For vehicles with Adaptive Cruise Control (ACC), use an 11mm socket to remove the three nuts from the ACC sensor on the driver side. Remove the sensor, unplug the wiring harness and set the sensor aside.

For 2016-2017 Raptor models: Use a 15mm socket to remove the side bolts from the front underbody skid plate. Then, remove the bolt in each of the two skid plate brackets – one on each side of the vehicle.

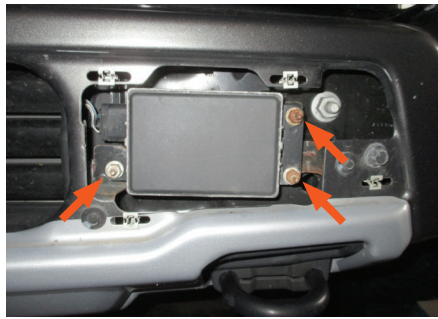

Step 6

Use a 21mm socket to remove the two nuts behind the bumper on the outside of the frame – one on either side of the vehicle.

Then, remove the three push pins along the upper edge of the bumper where the bumper meets the grille. This may be done while removing the bumper. These attach the bumper to the flexible rubber dirt guard.



2015-2018 F-150 (CONTINUED)

Step 7

Use a 21mm socket to remove the four nuts from the face of the bumper – two on either side of the vehicle. Carefully remove the bumper, unplugging any wiring harness from the bumper as necessary.

Set the bumper aside. Remove the plastic trim around the tow hook on each side of the vehicle.

Skip to Step 12.

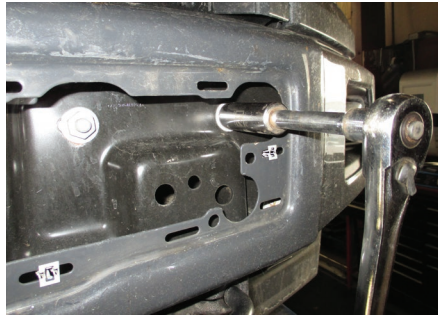

FASCIA REMOVAL EXPEDITION AND NAVIGATOR

Step 8

Open the hood and use a Phillips head screwdriver to remove the 12 push pins in the top radiator cover panel – six on each side.

Once removed, set the panel aside.

Step 9

Use a T30 Torx bit to remove the four screws in the top portion of the grille – two on each side.

For Navigator models: Use a 10mm socket to remove the two screws in the outer fascia piece – one on each side as shown. Also, remove the two hood latch screws on the driver side.

Step 10

Use a 7mm (10mm on Navigator) socket to remove the three screws from the front inner edge of the wheel well. Then, pull back the wheel well liner and use a 10mm socket to remove the two bolts behind the liner, where the bumper cover meets the fender.

Repeat on the other side of the vehicle.

For Navigator models: Remove the two push pins from the center, underside of the bumper cover.

Step 11

Starting on the outer edges, pull the bumper cover out, releasing the clips. Work your way toward the center of the vehicle, unclipping the bumper cover. Carefully remove the bumper cover and set it aside so it will not be damaged during the rest of the installation.

TOW BAR BASE PLATE INSTALLATION

Step 12

Use a 15mm socket to remove the two bolts holding the tow hook in place.

Repeat on the other side of the vehicle.

Return the tow hooks and plastic trim to the vehicle owner.

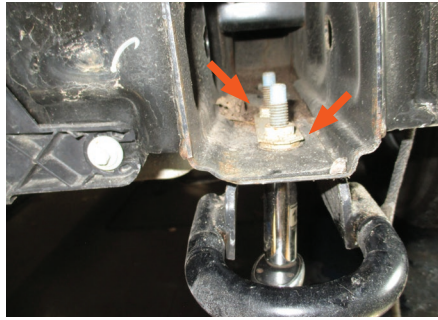

Step 13

Starting on the passenger side, position the tow bar base plate (#2) on the vehicle, ensuring the side plates are flush against the outside of the frame.

Reinstall the previously removed tow hook bolts into the holes in the bottom of the base plate.

Torque the bolts to 75 lb-ft.

Note: For vehicles without tow hooks, use the supplied 1/2" carriage bolts (#6), square hole spacers (#5) and 1/2" flange nuts (#7). Torque the bolts to 110 lb-ft.



Step 14

Using the side plate as a guide, drill two 17/32" holes. Then, fishwire the 1/2" carriage bolts (#6) with square hole spacers (#5) into the holes from the end of the frame. Loosely install the 1/2" flange nuts (#7).

Repeat on the other side of the vehicle and torque all 1/2" fasteners to 110 lb-ft.

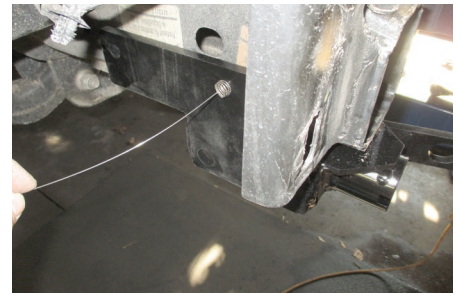

Step 15

Install the permanent safety cables (#4) and quick links (#8), looping them around the vehicle frame and linking them to the tow bar base plates (#1, #2). There must be one cable on each side of the vehicle.

Make sure the cables do not pinch or interfere with any hoses, wiring or other components.

See 'Installing the Permanent Base Plate Safety Cables' for additional information.



Step 16

Reinstall the ACC sensor if applicable. Reinstall the bumper / cover, plugging in any previously disconnected wiring harnesses.

Reinstall any fascia and other components that were removed during the install.

Return any unused factory fasteners to vehicle owner.

When ready to tow, install the tow bar mounting tabs (#3). When not towing, insert the socket plugs (#9) into the ends of the tow bar base plates (#1, #2).



Final Installed Image



SAFETY CABLE INSTALLATION

Installing the Permanent Base Plate Safety Cables

When dinghy towing a vehicle with a tow bar, base plate safety cables should be used at all times. In the event of a disconnect, the safety cables are designed to help prevent complete vehicle separation. When installing the safety cables, use the illustrations below as a guide.

Installation guidelines

1. The cables must be connected to the base plate and the vehicle frame.
2. Two cables must be installed.
3. Each cable must meet or exceed the gross weight of the towed vehicle.
4. Make sure cables do not pinch or interfere with hoses, wiring or other components.

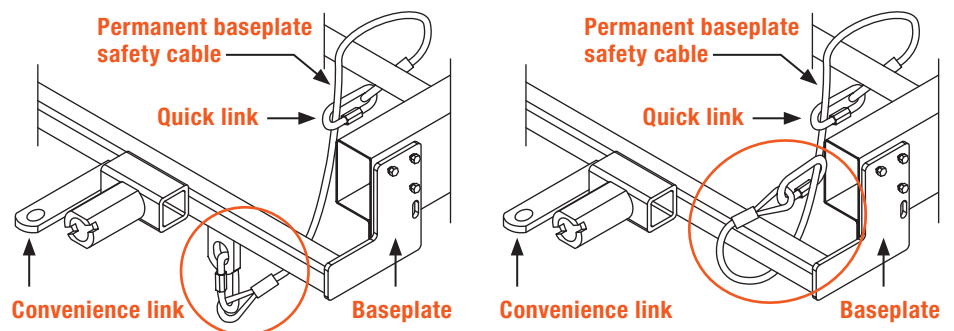

Note: Base plate safety cables are not a replacement for safety chains connecting the tow vehicle to the towed vehicle.

ADDITIONAL INFORMATION

Towing Tips

Check your equipment

Periodically check the condition of all towing equipment. Ensure all fasteners are tight and that all structural components are sound. Do not tow with worn or damaged parts.

Towing vehicle and trailer manufacturer's recommendations

Review the owner's manual for your towing vehicle and trailer for specific recommendations, capacities and requirements.

Product Registration and Warranty

CURT Group stands behind our products with industry-leading warranties.

Provide feedback and help us to improve our products by registering your purchase at: warranty.curtgroup.com/surveys