

REVISION HISTORY

REV	DESCRIPTION	DATE	NAME
A00	Initial Design	11/12/08	RJT

STEP #1

INSTALL 16" OF HEATSHRINK. MAKE SURE TO SLIDE IT INSIDE THE DISTRIBUTOR'S STRAIN RELIEF.

HEATSHRINK: 170049

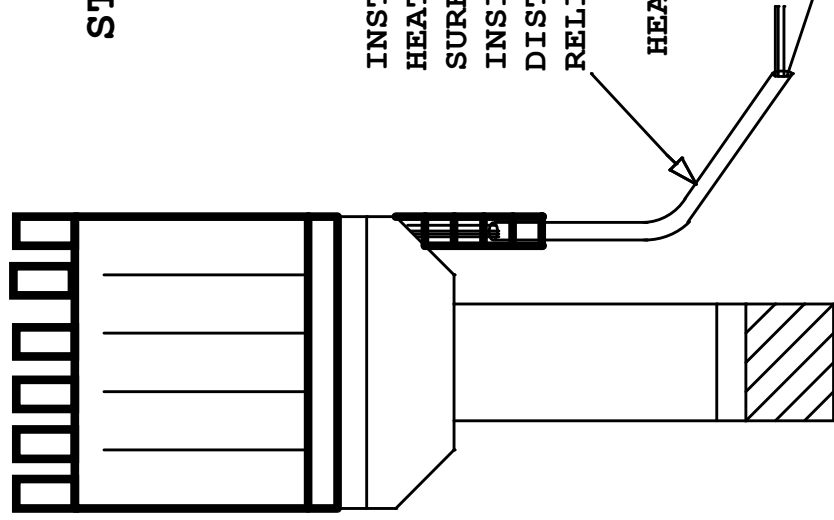

STEP #2

USE BLUE HANDLE WIRE CRIMPERS TO CRIMP PINS

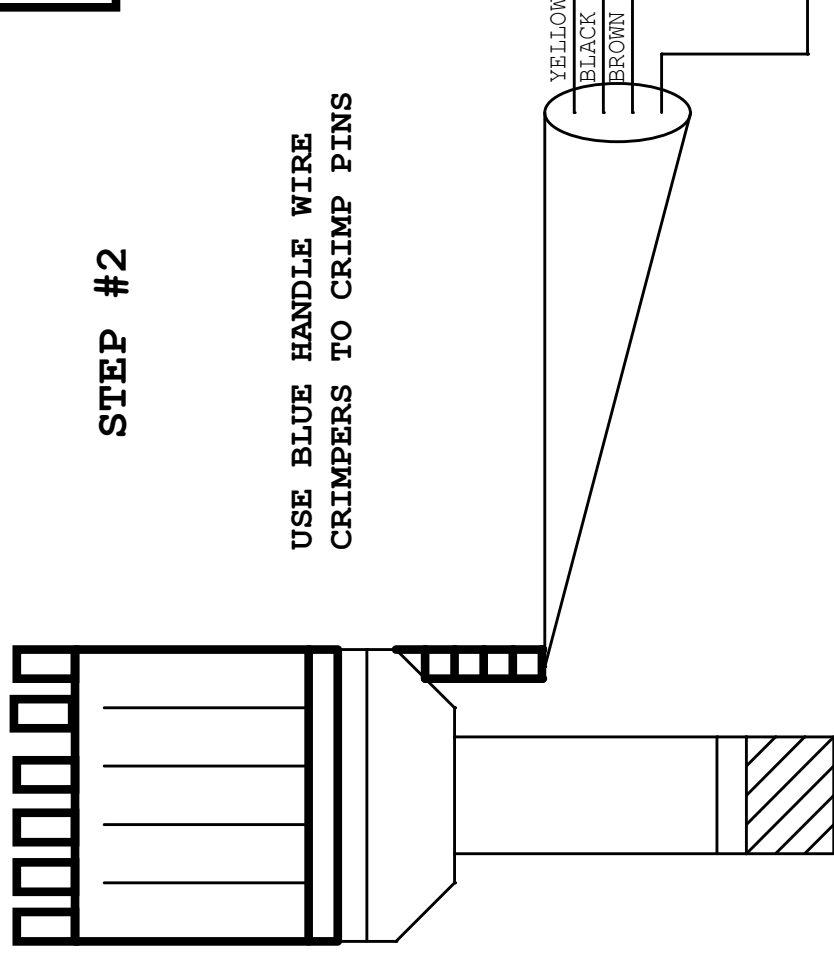

INSTALL A 1/4" PIECE OF HEATSHRINK AROUND THE NUMBER 1 POST ON THE CAP

HEATSHRINK: 170055

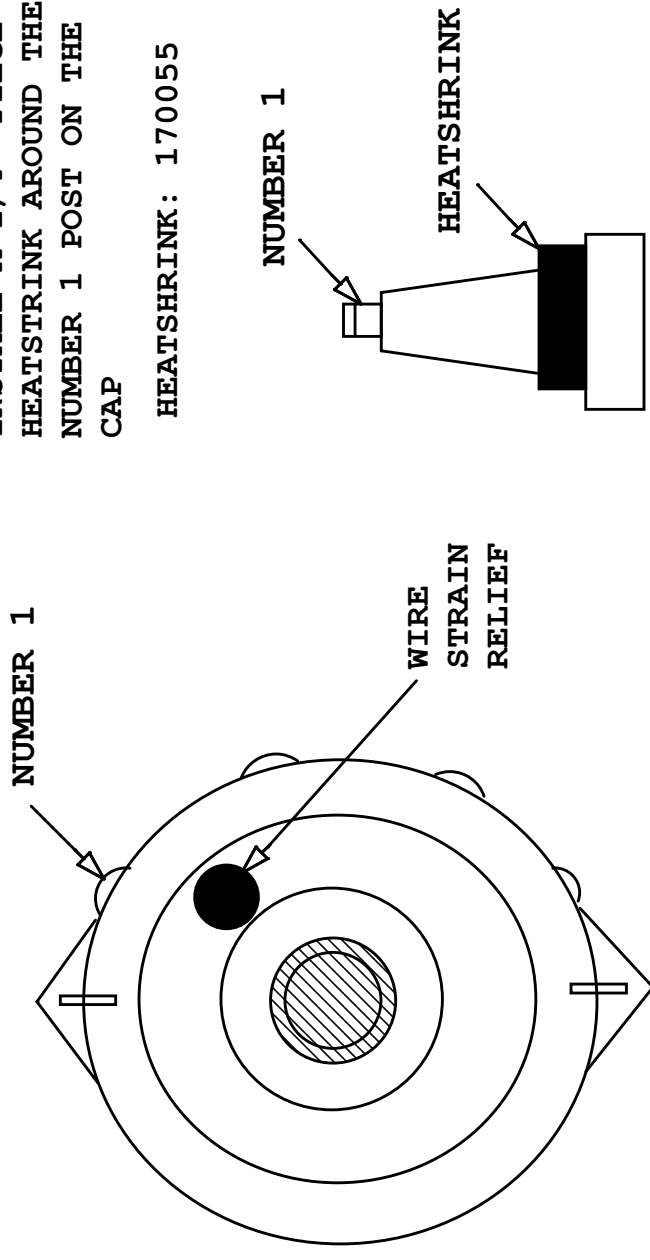

VIEW FROM BOTTON OF DISTRIBUTOR

- (1) CONNECTOR: 170264
- (5) RUST SEALS: 170087
- (1) LOCK: 170213
- (3) TERMINAL: 170557
- (3) BLUE SEALS: 170558

FAST

FUEL AIR SPARK TECHNOLOGY

3753 Old US23, Suite 300, Brighton, MI 48114

Mopar HEMI Distributor Connector Installation

Title	
Size	Document Number
A	305013
Date: Monday, November 12, 2007	
Sheet	1 of 1
Rev	A00