



IMPORTANT WARRANTY & INSTALLATION
INSTRUCTIONS ATTACHED

*Please Forward All Attached Information to Consumer
Warranty Not Valid Unless Returned to CORSA Exhaust*

We ask that you take a few moments to complete our warranty registration form:

TO ACTIVATE YOUR LIMITED LIFETIME WARRANTY GO TO:
CORSAPERFORMANCE.COM/WARRANTY



**For Full-Color Installation Instructions, Please Visit:
CORSAPERFORMANCE.COM and Search by Part Number**

Please be sure to review the enclosed instructions prior to beginning the installation process. If you have any questions about the enclosed parts, instructions or encounter a problem during installation:
CALL CORSA PERFORMANCE TECHNICAL ASSISTANCE AT 800.486.0999

Please take time to read and understand these installation instructions.

CORSA recommends that the installation of this system be performed by a qualified service center or professional muffler installer who has the necessary equipment, tools and experienced personnel. However, if you decide to perform this install, the use of a hoist and an additional person will be required.

CAUTION: Never work on a hot exhaust system. Allow time for the vehicle to cool. Always wear eye protection when working under a vehicle.

Recommended Tools:

- 3/8" drive ratchet
- 3/8" drive 15mm deep socket
- Grommet pullers
- Soap and water solution
- Torque Wrench
- Penetrating lubricant spray
- Safety glasses

Please confirm that all parts are present before beginning the factory exhaust system removal and CORSA exhaust system installation.

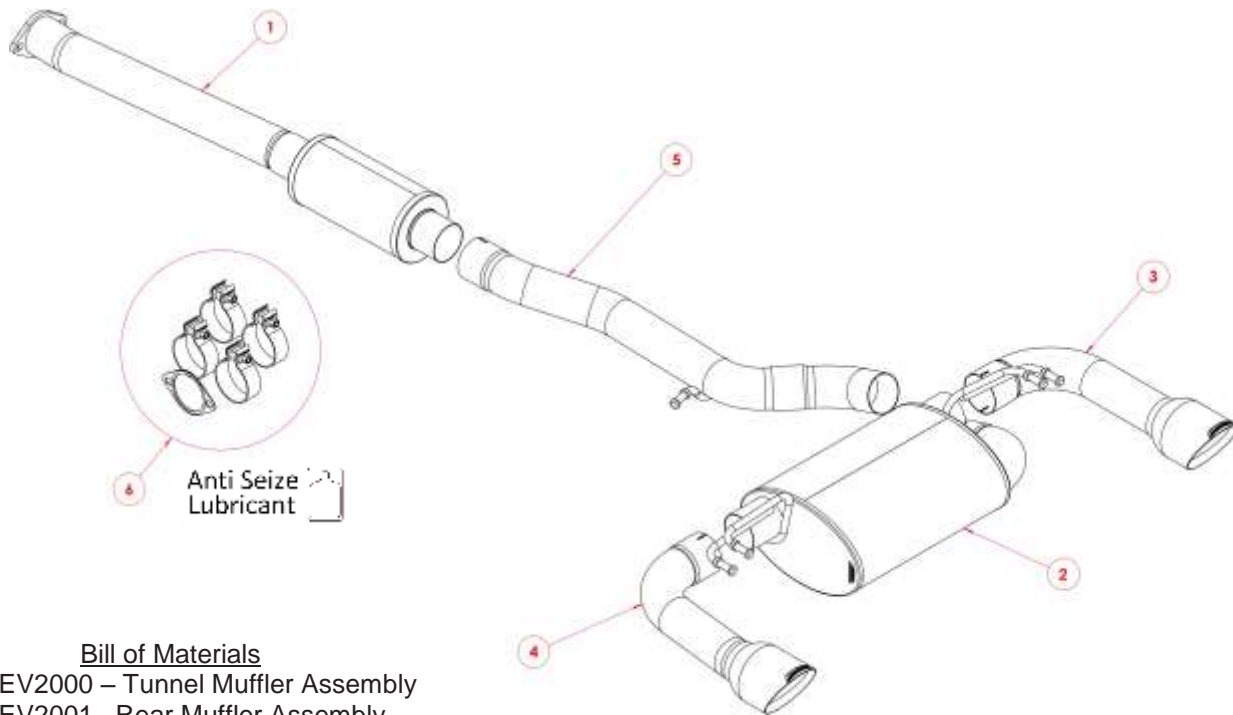

Bill of Materials

1. 44EV2000 – Tunnel Muffler Assembly
2. 44EV2001 – Rear Muffler Assembly
3. 44EV3000(BLK) – Passenger Tip Assembly
4. 44EV3001(BLK) – Driver Tip Assembly
5. 44EV4002 – Axle Pipe
6. 44EV7005 – Hardware Kit

Factory Exhaust System Removal:

1. Remove the hardware that secures the cat back to downpipe flange connection of the factory center pipe using a 15mm socket. Place a support under the front of the system to ensure it doesn't fall during removal. Set the two M12 bolts to be reused during the installation process. **(Fig A)**
2. Remove the bolt securing the front hanger grommet located in front of the rear muffler using a 12mm socket. **(Fig B)**
3. Remove both driver and passenger side hanger grommets located on either side of the rear muffler using grommet pullers or a similar device. Remove the grommets from the vehicle mounted hangers keeping the grommets attached to the exhaust. **(Fig C & D)**

Note: The use of a soap and water solution may aid in the removal of hanger grommets.

4. The stock exhaust system will be removed as a single unit. Carefully remove the factory exhaust by moving it slightly forward to bypass the heat shield at the downpipe flange. Then lower the exhaust down towards the rear of the vehicle. **(Fig E & F)**
5. Once the system is removed from the vehicle, remove the driver and passenger side hanger grommets from the system as they will be reused during the installation process of the Corsa system. Note the position of the grommets relative to the muffler as they will be installed in the same orientation on the Corsa system. **(Fig G)**

Note: The use of a soap and water solution may aid in the removal of hanger grommets.

6. Using grommet pullers or a similar device, remove the metal insert located in the front grommet. This shaft will not be reused. **(Fig H & I)**
7. Remove the original gasket at the downpipe flange connection. This gasket will not be reused. This completes the removal process. **(Fig J)**

REMOVAL PICTURES ON NEXT PAGE 

Factory Exhaust Removal Pictures



Fig. A



Fig. B



Fig. C



Fig. D



Fig. E



Fig. F

REMOVAL PICTURES CONTINUED ON NEXT PAGE 

Factory Exhaust Removal Pictures



Fig. G



Fig. H



Fig. I

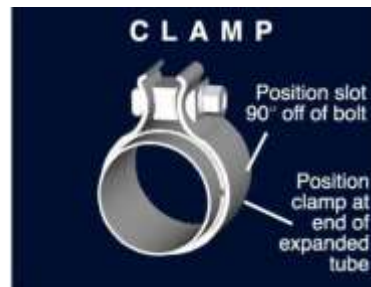

Fig. J

Installation of CORSA Exhaust System:

NOTE: Apply the anti-seize lubricant (supplied) to the threads **ONLY** of all the clamps and flange bolts. Failure to follow this procedure can cause nuts to seize on clamps and potentially destroy threads. After applying anti-seize lubricant, be sure to thoroughly clean your hands, as lubricant will tarnish stainless steel. All clamps should be tightened using a properly calibrated Torque Wrench. Using an air impact gun will damage the clamp and reduce its ability to effectively seal the joint. It may also cause the joint to separate, thereby causing damage to your exhaust system and to your vehicle.

NOTE: Align all clamps so that the center of the clamp bolt is 90 degrees from the notch in the pipe. (See Fig. CLAMP)



1. Remove all exhaust system components from the shipping boxes, including the clamps, gasket, and hardware.
2. Locate the provided flange gasket, the two M12 x 1.25 bolts removed from step 1 of the stock exhaust removal process, and the tunnel muffler assembly. Place the flange gasket on the downpipe flange (**Fig A**), followed by the tunnel muffler assembly (**Fig B**), and bolt it down using the M12 bolts and a 15mm socket. Do not fully tighten the bolts at this time. (**Fig C**)
3. Locate a 3" Torca clamp and slide it over the expanded end of the axle pipe assembly. Install the clamp on the axle pipe assembly so that the bolt is vertical, with the nut towards the ground and the bolt is towards the inside of the car when the expanded end of the axle pipe is installed over the rear of the tunnel muffler. (**Fig D**) Insert the axle pipe hanger into the factory grommet. (**Fig E**) Adjust the position and rotation of the axle pipe until the hanger grommet is perpendicular to the mounting rod for the grommet and the tunnel muffler has adequate clearance to the drive shaft. (**Fig F & G**) Tighten the clamp using the ratchet and 15mm deep socket until the axle pipe is snug on the tunnel muffler. (**Fig H**) Center the gasket on the flange, and then tighten the flange bolts using a 15mm socket. Torque flange bolts to spec.

Note: The use of a soap and water solution may aid in the installation of the hanger grommets.

4. Locate a 3" Torca clamp and slide it over the expanded inlet of the rear muffler assembly. Insert the rear muffler hanger grommets removed during step 5 of the stock exhaust removal process onto the corresponding hangers of the rear muffler assembly. (**Fig I**) Next, insert the hanger grommets onto the vehicle muffler hangers. (**Fig J & K**) Slide the muffler inlet onto the axle pipe. Tighten the clamp using the 15mm deep socket until the rear muffler inlet is snug on the axle pipe. (**Fig L**)

Note: The use of a soap and water solution may aid in the installation of the hanger grommets.

INSTALLATION INSTRUCTIONS CONTINUED ON NEXT PAGE 

5. Locate a 3" Torca clamp and slide it over the expanded end of the passenger's side tip assembly. Slide the tip assembly over the passenger outlet of the rear muffler assembly. **(Fig M)** Adjust the depth and rotation to the center of the tips in the cutout in the rear valence. Make sure to leave about a ¼" gap between the hanger grommet and the tip pipe. **(Fig N)** Tighten the clamp using the ratchet and the 15mm deep socket until the tip assembly is snug on the rear muffler assembly. **(Fig O)**
6. Repeat step 6 for the driver's side tip assembly. **(Fig P & Q)**
7. Visually inspect and adjust the exhaust system position, tip alignment, clamp orientation, and exhaust pipe clearance. **(Fig R)**
8. When the exhaust system is in the desired location, tighten the nuts on the clamps. Starting at the front of the vehicle, torque the clamp nuts to 45 ft-lbs (61 N-m)
9. It is **STRONGLY SUGGESTED** that all clamps be checked and re-tightened (if necessary) to the recommended torque after initial road testing of the vehicle, as thermal cycling has occurred on the system. Please wait until system has fully cooled to perform this step.

NOTE: During cold weather start-ups, you may experience an exhaust sound that is deeper and louder in tone than usual. This is temporary and will diminish to normal levels once your engine has reached its normal operating temperature.

NOTE: Immediately following the installation of your exhaust system, you may experience a trace of smoke after initial start-up. **DO NOT** be alarmed. The smoke is caused by the burning of a small amount of forming oil residue used in the manufacturing process.

INSTALLATION PICTURES ON NEXT PAGE 

CORSA Exhaust Installation Pictures



Fig. A



Fig. B



Fig. C



Fig. D



Fig. E



Fig. F

INSTALLATION PICTURES CONTINUED ON NEXT PAGE 

CORSA Exhaust Installation Pictures:



Fig. G



Fig. H



Fig. I



Fig. J



Fig. K



Fig. L

INSTALLATION PICTURES CONTINUED ON NEXT PAGE 

CORSA Exhaust Installation Pictures:



Fig. M



Fig. N



Fig. O



Fig. P



Fig. Q



Fig. R