



dB Performance Exhaust System Installation
Cat-Back Exhaust System
2009-10 Ford F-150
Single Side Exit w/ 4" Slash Cut Tip
PART NUMBER 24310

Please take time to read and understand these installation instructions.

We recommend that the installation of this system be performed by a qualified service center or professional muffler installer who has the necessary equipment, tools and experienced personnel. However, if you decide to perform this install, the use of a hoist and an additional person will be required.

CAUTION: Never work on a hot exhaust system. Allow time for the vehicle to cool. Always wear eye protection when working under a vehicle.

Please confirm that all parts are present before beginning the factory exhaust system removal and dB Performance Exhaust system installation.

Recommended Tools:

- Safety Glasses
- 13mm Socket
- 10mm Socket
- 15mm Socket
- 3/8" Ratchet
- Grommet Pullers
- 12" Ratchet Extension
- Torque Wrench
- Soap & Water Solution
- 9/16" Socket

Bill of Materials:

- 1 20FF2000 (dB Muffler Assembly)
- 2 16SE3023 (dB Slash Cut Tip)
- 3 20FF4034 (Intermediate Pipe Assembly)
- 4 20FF4037 (Tailpipe Assembly)
- 5 20FF7030 (Hardware Kit)

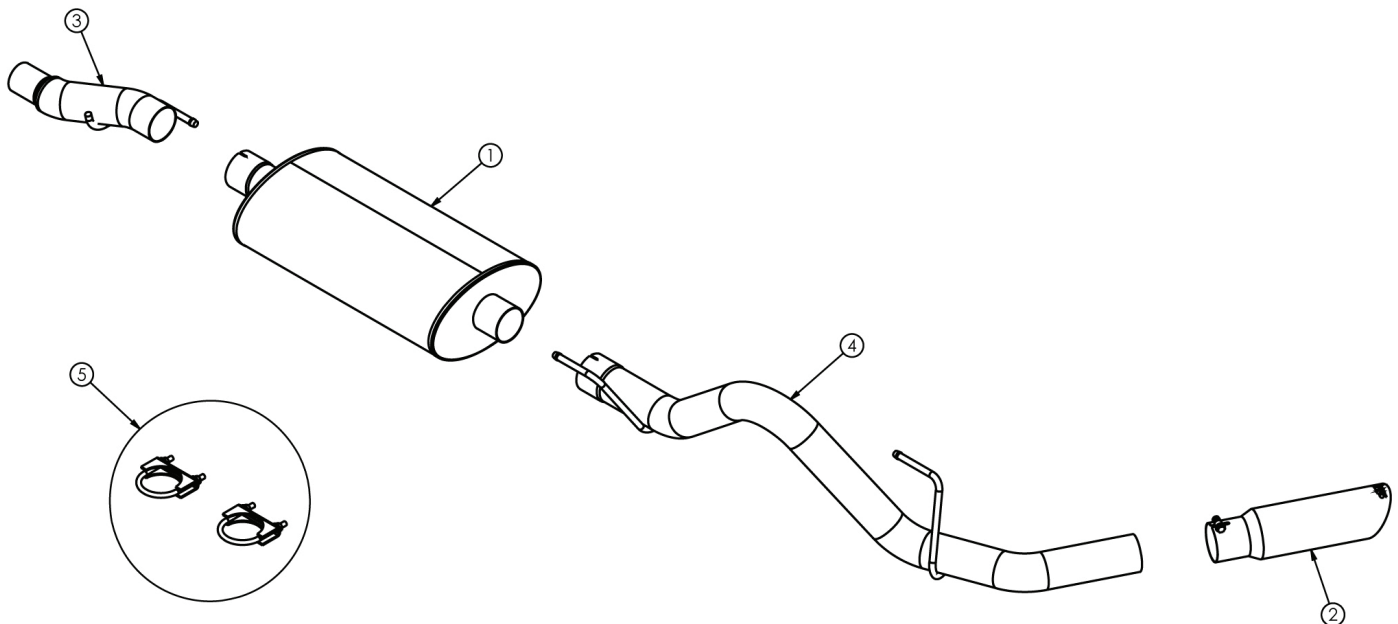

Removal of Stock Exhaust System:

1. Remove both bolts that secure the flange connection on the factory center pipe using a 13mm socket and ratchet. **(See Fig. A)**
2. Unbolt the muffler hanger mount from the chassis using a 10mm socket and ratchet. **(See Fig. B)**
3. Unbolt the front tailpipe hanger mount from the chassis using a long extension, and a 10mm socket and ratchet. **(See Fig. C)**
4. Unbolt the rear tailpipe hanger mount from the chassis using a long extension, and a 10mm socket and ratchet. **(See Fig. D & E)** Carefully remove the entire stock exhaust system from the vehicle by moving it forward and down past the rear axle. **(See Fig. F)** The stock exhaust is removed as one piece and is fully intact.
5. With the stock exhaust on the ground, loosen the clamp on the factory center pipe using a 15mm socket and ratchet. **(See Fig G)** Rotate the center pipe until the retaining boss on the stock exhaust is aligned with the slot and then remove the center pipe from the rest of the factory system. **(See Fig. H & I)**

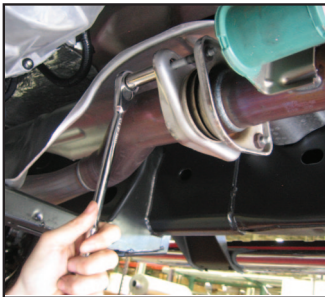

FIG. A



FIG. B

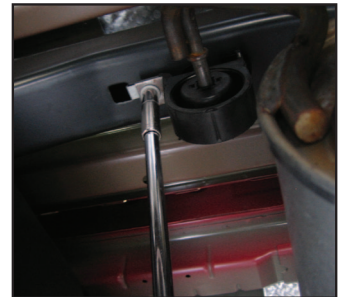

FIG. C



FIG. D

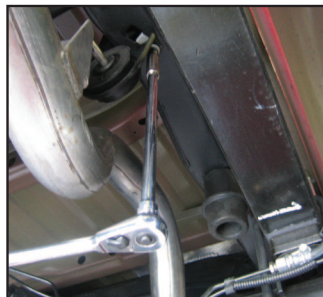

FIG. E

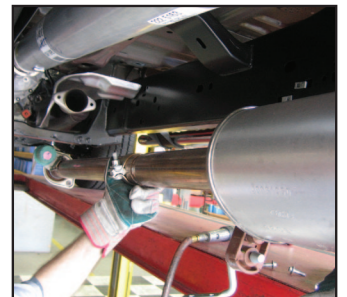

FIG. F



FIG. G



FIG. H



FIG. I

- Remove the factory muffler and tailpipe hangers from the rubber isolators on the hanger mounts using a grommet puller or a similar device. (See Fig. J, K, & L) Note the position and orientation of each hanger mount. Set aside the muffler and tailpipe hanger mounts and the retaining bolts to be reused during the installation process.

NOTE: The use of a soapy water solution may aid in the removal and later installation of the hangers in the rubber isolators.

- Removal is now complete. Installation of your dB Performance exhaust system can now begin.



FIG. J



FIG. K



FIG. L

Installation of dB Performance Exhaust System:

NOTE: The supplied double edge clamps in this system will crush and permanently deform the exhaust piping as they are tightened. **DO NOT** tighten these clamps any more than is necessary to lightly hold the exhaust components in place, until the very end of this installation process. It will be difficult or impossible to make any positional or rotational adjustments to the exhaust system after these clamps have been tightened down.

VERY IMPORTANT: Align all clamps so that the open edge of the clamp bracket is parallel and aligned with the notch in the pipe, and the outside edge of the clamp bracket is approximately 1/8" from the end of the pipe expansion. (See Fig. M) Failure to properly position or orient the clamps could result in a weak clamping load, or even a potential leak at the clamp joints.

- Remove all exhaust system components from the shipping carton, including the two supplied clamps.
- Locate the factory center pipe that was disconnected during the removal process, along with the two 13mm mounting bolts. Align the flanges, and snug tighten both of the bolts using a 13mm socket and ratchet. Make sure that the center pipe is oriented so that the notch at the rear of the pipe faces upwards. (See Fig. N)

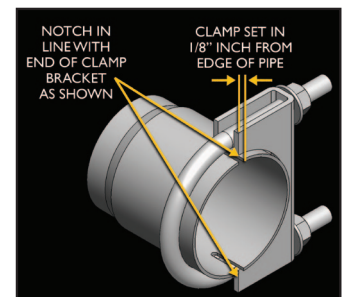

FIG. M



FIG. N

3. Locate the intermediate pipe assembly, and the muffler hanger mount, along with the two 10mm mounting bolts. Align the hanger mount with the mounting holes in the chassis, and secure with a 10mm socket and ratchet. Note the proper orientation of the muffler hanger mount as shown in the figure. Torque the 10mm bolts to factory specs. **(See Fig. O)**

NOTE: Using a soapy water solution on the muffler hanger grommet at this time will make the following step much easier to accomplish.

4. Insert the intermediate pipe hanger into the factory muffler hanger grommet, and then move the front end of the intermediate pipe forward into the factory center pipe. Seat the front end of the intermediate pipe assembly into the center pipe expansion, past the end of the factory clamp. Use a rubber mallet if necessary to make sure the pipe is properly seated. The end of the hanger will be flush with the end of the hanger mount rod when the depth of the pipe is correct. **(See Fig. P)**
5. Rotate the intermediate pipe assembly until the grommet is straight up and down, and the hanger is directly underneath the hanger mount rod. Snugly tighten the factory clamp on the center pipe using a 15mm socket and ratchet. **(See Fig. Q)**
6. Locate the dB Performance muffler, and one of the supplied clamps. Slide the expanded end of the muffler inlet pipe onto the intermediate pipe. **(See Fig. R)**

IMPORTANT: Make sure that the small drain hole in the rear of the muffler is facing straight downwards when the muffler is installed. **(See Fig. S)**

7. Secure the muffler in place with the supplied clamp as shown, using a 9/16" socket and ratchet, making sure to only tighten the clamp nuts just enough to hold the muffler onto the intermediate pipe. Note the position and orientation of the clamp. **(See above clamp notes & See Fig. T)**



FIG. O



FIG. P



FIG. Q

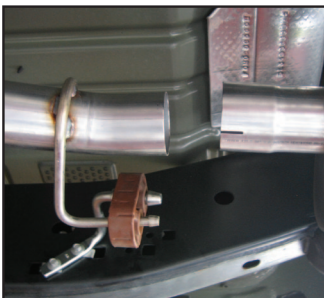

FIG. R



FIG. S



FIG. T

NOTE: The unbolted tailpipe hanger assemblies from the removal process should now be installed onto the corresponding hangers on the tailpipe by pushing the rubber grommets onto the hangers. Once again, a soapy water solution will aid in this installation process. **(See Fig. U & V)**

8. Locate the rear tailpipe assembly, along with the 10mm hardware to secure the hanger mounts, and the last of the supplied clamps. Slide the expanded end of the tailpipe onto the outlet of the rear muffler. **(See Fig. W)** Align the hanger mounts with the mounting holes in the chassis, and secure with a 10mm socket and ratchet, and a long extension. Note the proper orientation of the muffler hanger mounts as shown. Torque the 10mm bolts to factory specs. **(See Fig. X,Y, & Z)**
9. Rotate the rear tailpipe assembly until the rearmost section of the pipe is horizontal, and then secure it with the supplied clamp as shown, using a 9/16" socket and ratchet, making sure to only tighten the clamp nuts just enough to hold the tailpipe onto the muffler. **(See Fig. AA)**



FIG. U



FIG. V

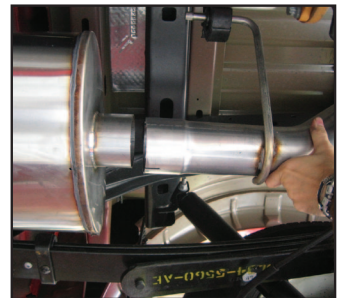

FIG. W



FIG. X

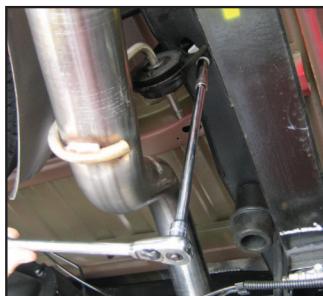

FIG. Y



FIG. Z



FIG. AA

Continue to Page 6.

10. Locate the dB Performance slash cut tip assembly, which has a clamp built into it. Slide the clamp end of the tip onto the end of the tailpipe. **(See Fig. BB)** Rotate the tip until the dB Performance logo is centered on the top side of the tip. **(See Fig. CC)** Snugly tighten the clamp as shown using a 15mm socket and ratchet, making sure to only tighten the clamp enough to hold the tip in place on the tailpipe. **(See Fig. DD)**
11. Visually inspect the exhaust system position, tip alignment, clamp orientation and position, and exhaust pipe clearance. Make any necessary adjustments at the slip joints.
12. Fully tighten the 13mm bolts on the center pipe flange. Torque to the factory specs. Next, tighten the clamp on the factory center pipe to 45 ft-lbs.
13. Start at the front of the vehicle, and tighten the nuts on the two supplied clamps on each side of the muffler. Torque the nuts on the clamps to 35 ft-lbs. Finally, tighten the clamp that is built into the tip to 45 ft-lbs.
14. It is **STRONGLY SUGGESTED** that all clamps be checked and re-tightened (if necessary) to the recommended torque after initial road testing of the vehicle, as thermal cycling has occurred on the system. Please wait until system has fully cooled to conduct this process.

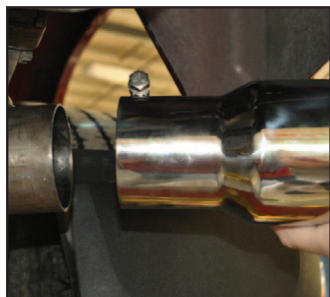

FIG. BB



FIG. CC



FIG. DD

NOTE: During cold weather start-ups, you may experience an exhaust sound that is deeper and louder in tone than usual. This is temporary and will diminish to normal levels once your engine has reached its normal operating temperature. **NOTE:** Immediately following the installation of your exhaust system, you may experience a trace of smoke after initial start-up. **DO NOT** be alarmed. The smoke is caused by the burning of a small amount of forming oil residue used in the manufacturing process.