



INSTALLATION INSTRUCTIONS REMOTE COOLER INSTALL KIT PART # 15450, 15500 & 15660

Please read these instructions completely before starting the installation.

KIT CONTENTS

QTY.	DESCRIPTION	QTY.	DESCRIPTION
1	Oil Cooler Assembly	1	3/4-16 Sleeve Nut (Yellow)
1	Sandwich Adapter	1	18mm Sleeve Nut (White)
1	2 3/4" O-ring	1	20mm Sleeve Nut (Black)
1	Adapter Plate	1	22mm Sleeve Nut (Green)
1	3 1/2" O-ring	1	13/16-16 Sleeve Nut (Blue)
2	3/8" NPT x 1/2" Barb Fittings	1	13/16-16 Sleeve Nut (Red)
1	-8AN Male x 1/2" Barb Fitting	4	1/4-20 x 1" Hex Bolts
3	-8AN Female x 1/2" Barb Fitting	4	1/4-20 Lock Nuts
10ft	1/2" OEM Spec Hose	4	6" Zip Ties
1	In-line Thermostat Fitting	1	#10 Blue Ring Terminal
1	Thermostat Switch	2	Blue Female Connector
4	Hose Clamps	1	Blue Wire Tap Connector
8	1/4" Washers		

IMPORTANT

This kit is designed to fit all vehicles with engine block oil filter landings ranging from 2 3/4" to 3 1/2", which represents 75% of all vehicles. For vehicles with 2 1/2" oil filter landings, please visit www.dera.com for alternative Sandwich Adapter Kits.

In most cases the Factory Oil Filter will work with the supplied sandwich adapter. In some applications where the frame or exhaust system interferes with the new filter depth we recommend using a shorter filter length. **See chart below for possible filter options.**

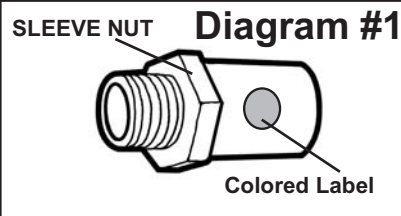

THREAD SIZE	LABEL COLOR	FRAM FILTER HEIGHT	FRAM P/N	WIX FILTER HEIGHT	WIX P/N	FRAM FILTER HEIGHT	FRAM P/N	WIX FILTER HEIGHT	WIX P/N
3/4-16	YELLOW	4.92	PH3600	4.83	51516	3.34	PH3614	3.4	51348
13/16-16	BLUE/RED	4.94	PH3429	4.83	51045	3.36	PH3506	3.4	51042
18mm x 1.5	WHITE	4.94	PH3980	4.83	51036	3.36	PH3387A	3.4	51040
20mm x 1.5	BLACK	3.47	PH7317	N/A	N/A	3.39	PH3593A	3.14	51381
22mm x 1.5	GREEN	4.94	PH3750	4.57	57026	3.98	PH2	3.43	57060

COOLER LOCATION

Cooler can be mounted anywhere space permits. When selecting the best location for your vehicle, look for a location that will deliver the maximum airflow.

COOLER MOUNTING

1. Holding the cooler in place use a marker to identify the four mounting hole locations.
2. Using a drill and 9/32" drill bit, drill the four mounting holes in the desired location.
3. Using the 1/4-20 Bolts, Washers & Lock Nuts Included, install cooler.

PRE-INSTALLATION

Important: The Adapter Plate & O-ring are designed to fit vehicles with a 3 1/2" filter landing. Primarily 1963-2007 GM SB & BB V-8 engines. There are 6 supplied Sleeve Nuts in this kit. Only 1 Sleeve Nut will be used for your application.

SELECTING COMPONENTS

To easily select the correct components for your application, follow the steps below. Then proceed to the SANDWICH ADAPTER INSTALLATION section.

Selecting the Sandwich Adapter and/or Adapter Plate

1. Remove the factory oil filter from the vehicle.
2. Using a rag, clean the oil filter landing on the engine.
3. Take the supplied Sandwich Adapter and Adapter Plate.
4. To determine if your application uses the supplied Adapter Plate, first hold the Adapter Plate up to the oil filter landing on the engine block. The casting needs to seat directly onto the landing without obstruction. If the Adapter Plate is too large, then disregard the Adapter Plate and O-ring. (See Diagram #3)
5. Take the supplied Sandwich Adapter and hold it up to the oil filter landing on the engine block. The casting needs to seat directly onto the landing without obstruction. (See Diagram #2)

Selecting the Sleeve Nut

1. The Red Sleeve Nut is ONLY used when the Adapter Plate is being used. If you have previously determined that your application will use the Adapter Plate then disregard the 5 remaining Sleeve Nuts. If you are not using the Adapter Plate, please disregard the Red Sleeve Nut.
2. Using the remaining 5 supplied Sleeve Nuts, try and screw each Sleeve Nut onto the filter nipple on the engine block until the correct size will completely thread onto the nipple. Once you have located the correct Sleeve Nut, disregard the remaining 4 Sleeve Nuts.

(Page 1)

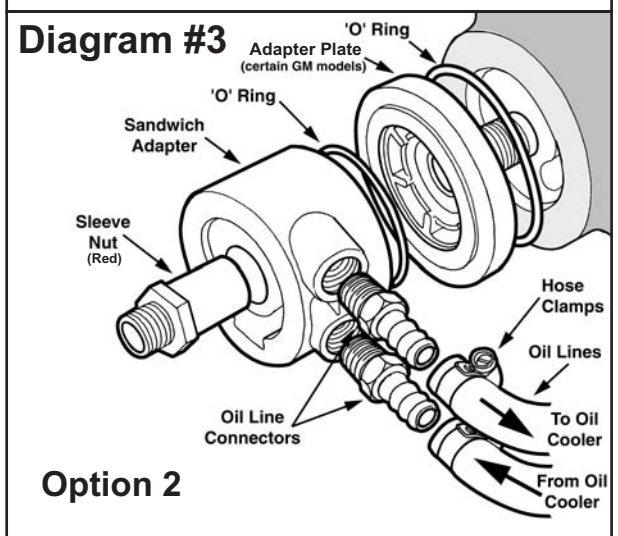
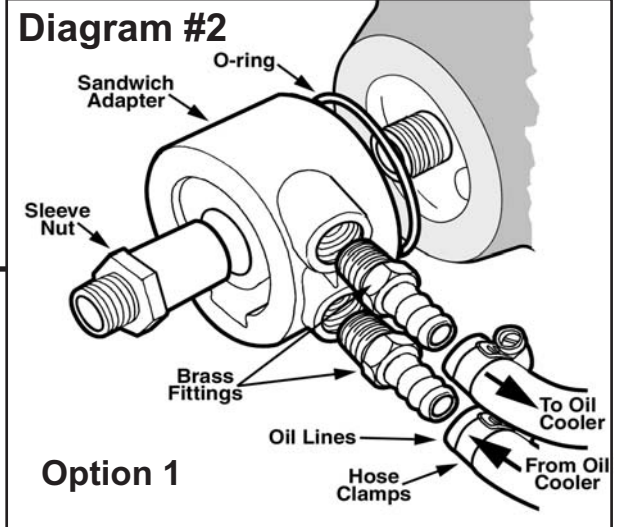

SANDWICH ADAPTER INSTALLATION

1. Take the Sandwich Adapter and two 3/8" NPT x 1/2" Hose Barbs provided, Using Teflon Tape or suitable sealant, install the hose barb fittings onto the Sandwich Adapter.
2. Take the pre-determined Sleeve Nut. Make a note of the Colored Label on the Sleeve Nut. This will allow you to reference oil filter options if necessary.
3. Remove the Colored Label from the Sleeve Nut.
4. Apply a light coat of oil onto the O-ring(s).
5. Take the O-ring(s) and install onto the Sandwich Adapter and Adapter Plate (if used)
6. Making sure the filter landing is clean from oil and dirt, take the Sleeve Nut, Sandwich Adapter, O-ring(s) and Adapter Plate (if used) and install onto the engine sliding the Sleeve Nut thru the Sandwich Adapter. Turn the Sleeve Nut clockwise onto the engines filter nipple. (See Diagram #2 & 3)
7. Using a Torque Wrench, torque the Sleeve Nut to 20 ft. Lbs.

IN-LINE THERMOSTAT INSTALLATION

Mounting Location

The recommended location for the In-line Thermostat Fitting is on the INLET side of the oil cooler, so the oil line that provides the cooler fluid from the engine.

Note: AN fittings do not require any thread sealant.

Warning: Always use two wrenches when tightening the In-line Thermostat Fitting to the oil cooler; failure to use a back up wrench could cause damage to the cooler core.

There are two options for installing the In-Line Thermostat.

1. Cooler inlet installation (See Diagram #4)

The In-line Thermostat Fitting is provided with a -8AN male and female threads.

- a) Attach the In-line Thermostat Fitting onto the INLET fitting on the oil cooler.
- b) Using Loctite or suitable sealant, carefully HAND TIGHTEN the Thermostat Switch clockwise onto the In-line Thermostat Fitting. Do not use a wrench or damage to the Thermostat Switch could occur.

2. Hose installation (See Diagram #5)

The kit provides two brass fittings designed to screw into the In-line Thermostat Fitting which converts the AN fittings to hose barbs. One is the -8AN Male x 1/2" Hose Barb and the other is the -8AN Female x 1/2" Hose Barb.

- a) Using the -8AN Male x 1/2" Hose Barb Fitting provided, attach the fitting to the female side of the In-line Thermostat Fitting.
- b) Using the -8AN Female x 1/2" Hose Barb Fitting provided, attach the fitting to the male side of the In-line Thermostat Fitting.
- c) Using the 1/2" OEM Spec Hose and Hose Clamps provided, cut a short piece of hose approximately 5 inches and attach one end of the hose to the oil cooler inlet and the other to EITHER of the Hose Barb Fittings.
- d) Using Loctite or suitable sealant, carefully HAND TIGHTEN the Thermostat Switch clockwise onto the In-line Thermostat Fitting. Do not use a wrench or damage to the Thermostat Switch could occur.

ROUTING HOSES

1. Using the 1/2" Hose and Hose Clamps provided, attach both ends of the hose onto the oil cooler/In-line Thermostat housing forming a loop.
2. Route the looped hose carefully along the frame to the Sandwich Adapter already installed on the engine making sure to stay away from moving parts, exhaust systems and any sharp objects. Cut hose at desired length.
3. Connect the outlet port on the Sandwich Adapter to the inlet port on the oil cooler.
4. Connect the inlet port on the Sandwich Adapter to the outlet port on the oil cooler.
5. Using the Hose Clamps and 6" Zip Ties provided, secure hoses in place.

THERMOSTAT SWITCH WIRING (See Diagram #6)

Important: Thermostat Switch is designed for a **maximum capacity of 15 continuous amps.**

The Thermostat Switch has two terminals coming off the main housing.

1. Attach EITHER terminal on the Thermostat Switch to the Positive (+) wire coming from the electric fan on the oil cooler.
2. Attach the remaining terminal on the Thermostat Switch to a 12V (+) Switched Ignition Source.
3. Attach the Negative (-) electric fan lead to a good chassis Ground (-).

VEHICLE TESTING

1. Start the engine and quickly check all connections for leaks.
2. Turn-off the engine and check oil level.
3. Add oil as needed.

Warning: Installation of accessories should only be undertaken by those with mechanical knowledge and are familiar with working on vehicles. Always use eye protection (goggles, safety glasses or shield). Park the vehicle in a well lit area, on level ground and apply the parking brake. Only work on a cold vehicle that has been sitting overnight, failure to do so will result in severe burns and injury. Before starting the vehicle, make sure no tools or any other items are left under hood that could interfere with or be drawn into moving parts of the engine. Failure to follow instructions can lead to severe damage and personal injury.

Diagram #4

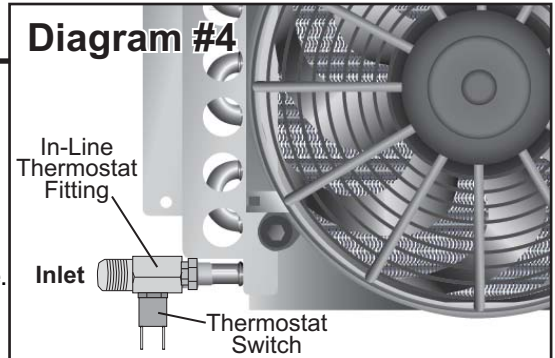
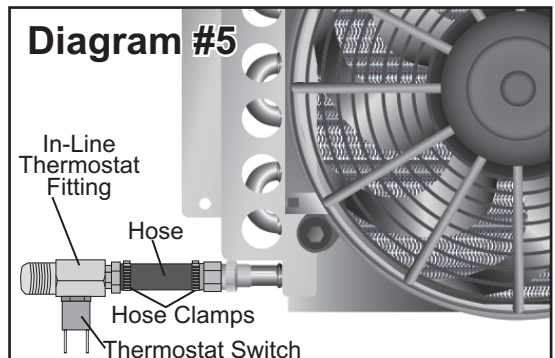

Diagram #5



WARNING

All bends in hose need to have a minimum radius of 5" or the diameter of a small coffee can.

Diagram #6

