



INSTALLATION INSTRUCTIONS DUAL ELECTRIC FAN RELAY HARNESS PART # 16765

Please read these instructions completely before beginning installation

KIT CONTENTS

QTY.	DESCRIPTION
2	Relay Wire Harness
2	40/60 Amp Relay

TOOLS NEEDED

Wire Stripper
Crimping Tool

IMPORTANT

Each Relay will control up to two different fans with a **COMBINED MAXIMUM DRAW OF 25 CONTINUOUS AMPS.**

Diagram #1

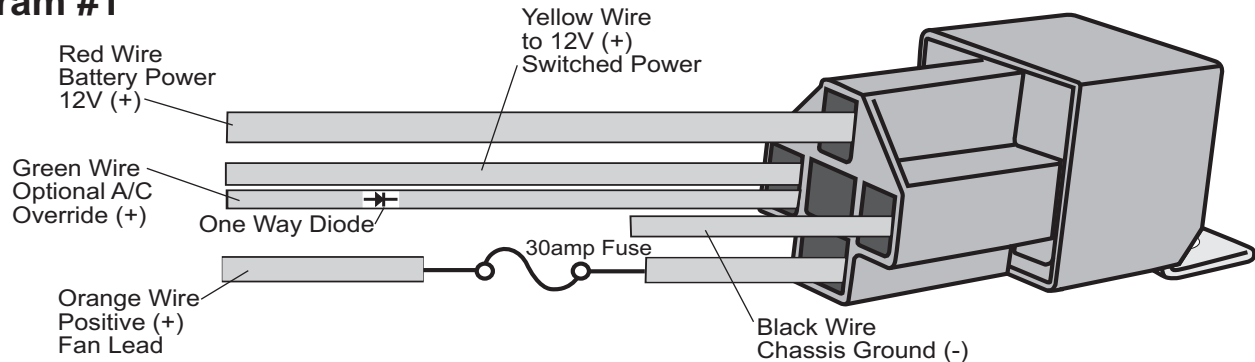

RED Wire - Attach to the Positive (+) Terminal of Battery

BLACK Wire - Attach to a good Chassis ground (-)

ORANGE Wire - Attach to the Positive Electric Fan Lead (Fan +)

YELLOW Wire - Attach to 12V (+) Switched Power (Thermostat or Manual Switch)

GREEN Wire* - (OPTIONAL) Attach to the Positive feed from the A/C Clutch

*This wire will allow you to turn on the Electric Fan every time the vehicles air conditioning is turned on. If you do not wish to use this option, please disregard the Green wire.

Diagram #2

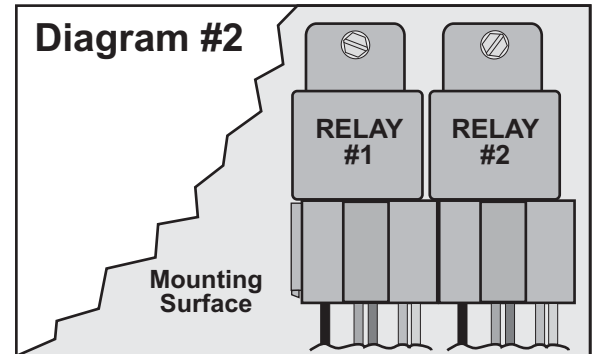
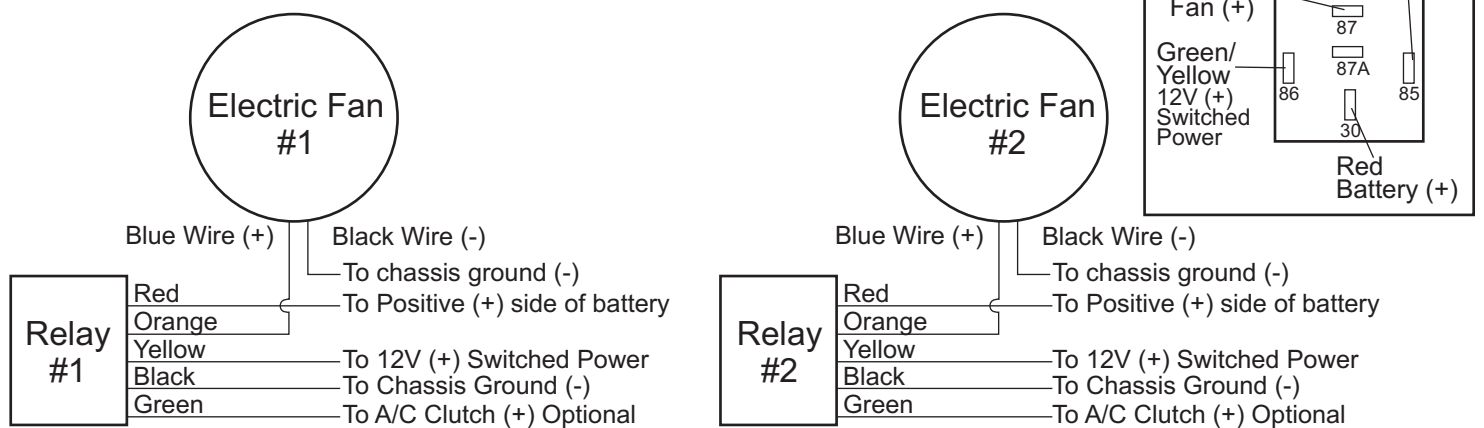

Diagram #3



Warning: Installation of accessories should only be undertaken by those with mechanical knowledge and are familiar with working on vehicles. Always use eye protection (goggles, safety glasses or shield). Park the vehicle in a well lit area, on level ground and apply the parking brake. Only work on a cold vehicle that has been sitting overnight, failure to do so will result in severe burns and injury. Before starting the vehicle, make sure no tools or any other items are left under hood that could interfere with or be drawn into moving parts of the engine. Failure to follow instructions can lead to severe damage and personal injury.