

IMPORTANT: Unless certified or exempted by The California ARB, Headers are not legal for sale in California on 1975 or later model vehicles, except for racing vehicles which are not legal for use or operation on any highway. Pre-Catalyst vehicles must utilize original air injection system if so equipped. It is the responsibility of the customer to reinstall the air injection device to his vehicle.



2701 N. Dettman Rd.
Jackson, MI 49201

INSTALLATION INSTRUCTIONS
NUMBER: 89017

1975-80 Chevelle, Monte Carlo
1978-80 Buick Century, Oldsmobile Cutlass,
Pontiac LeMans & Grand Prix
1975-81 Chevrolet Camaro & Z28
305-350 CID Eng.

NOTE: HEADER DUALS. THIS KIT WAS DESIGNED FOR DYNOMAX HEADER #85121. IF THE KIT IS BEING INSTALLED WITH HEADERS OTHER THAN LISTED ABOVE, MODIFICATION WILL BE REQUIRED. DYNOMAX WILL NOT ASSUME RESPONSIBILITY FOR FIT OR PERFORMANCE.

NOTE: MUFFLERS AND MUFFLER U-CLAMPS ARE NOT SUPPLIED WITH THIS PERFORMANCE EXHAUST SYSTEM. DYNOMAX HAS DESIGNED THIS KIT FOR USE WITH SUPER TURBO MUFFLER PART #17731, OR AN EQUIVALENT 2 1/4" I.D. INLET x 2 1/4" I.D. OUTLET, SINGLE OFF SET OEM MUFFLER. GLASSPACK MUFFLERS MAY BE USED WITH SLIGHT MODIFICATIONS.

DANGER WARNING: SHOULD THE PURCHASER DECIDE TO INSTALL ANY EXHAUST PRODUCT AT HOME, BE WARNED THAT PASSENGER CAR OR LIGHT DUTY TRUCK/VAN "BUMPER" JACKS ARE INTENDED FOR EMERGENCY USE ONLY. THE USE OF FRAME CONTACT JACK STANDS IN CONJUNCTION WITH A FLOOR JACK AS MAIN SUPPORT IS HIGHLY RECOMMENDED TO MINIMIZE ACCIDENTAL DROPPING OF A VEHICLE DURING THE INSTALLATION PROCESS.

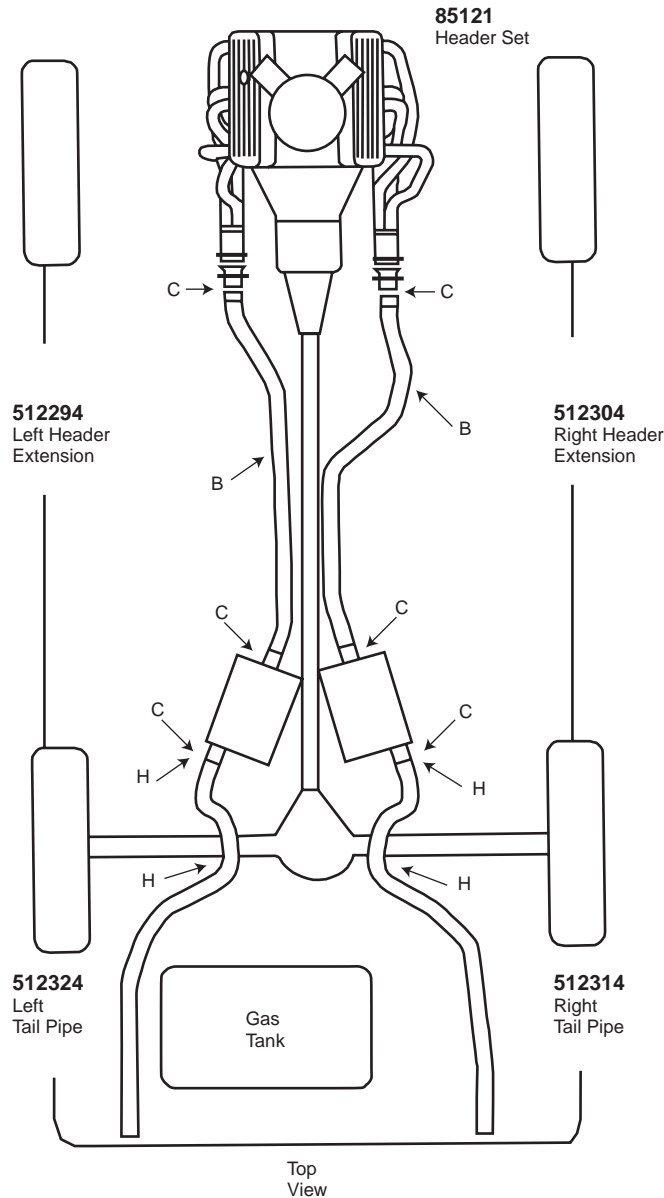

1. Install Header Extensions, Part **#512294** & **#512304** using 2½" U-Clamps. **Do not tighten.**
2. Install mufflers on end of the Header Extensions. Put clamp in place but **do not tighten.** Rotate extensions and mufflers to clear drive shaft and frame. Over the rear of the muffler, you will find a cross member or some type of body mount and a hole that can accept a 5/16" bolt and rubber hanger.
3. Install tail pipes, Part **#512314** & **#512324** and center bump over rear axle housing for maximum clearance.
4. As the tail pipe goes under the frame on its way out to the rear of the vehicle, find a hole in the area, or drill a new hole, to bolt the 90° metal bracket and rubber hangers.
5. Make sure that all parts of the system are clear of frame members, all hoses, suspension elements and brake & fuel lines. Starting at the exhaust Headers, tighten all connections making sure all parts are clear and will not leak or rattle.
6. Periodically check tightness of all Header Bolts.

Parts List

HEADER DUALS 89017

1	512294 Left Header Pipe	6	5/16" x 1¼" Bolts
1	512324 Left Tail Pipe	2	5/16" x 1½" Bolts
1	512304 Right Header Pipe	8	5/16" Nuts
1	512314 Right Tail Pipe	8	5/16" Lock washers
2	107097 Brackets	2	143161 Male Grommets
4	160701 Hangers	2	143171 Female Grommets
4	138928 2¼" Clamps	10	145061 Fender Washers
2	138938 2½" Clamps	4	5208620 Hangers