

Universal Fan Hardware Kit 12V & 24V Installation Instructions

– Parts #1000 / #1001

BEFORE BEGINNING INSTALLATION, PLEASE READ THESE INSTRUCTIONS IN THEIR ENTIRETY VERY CAREFULLY. FAILURE TO COMPLY WITH ALL THE INSTRUCTIONS MAY INVALIDATE THE MANUFACTURER'S WARRANTY.

A. PREAMBLE

Congratulations on purchasing a Davies, Craig Universal Thermatic Fan Hardware Kit 12V / 24V.

B. KIT REQUIREMENTS:

The Davies Craig Fan Mounting Kit includes all parts necessary for universal fan mounting & wiring for both 12V and 24V units. If you wish to control the electric fan(s) you should purchase a Davies, Craig "Thermatic Switch Kit" Part: #0401, #0400 or #0444 from your retailer. If you wish to cool both the radiator and AC condenser you should purchase a "Thermatic Switch & Relay Kit" Part #0404 which contains the Thermatic Switch with an extra relay and wiring loom.

C. FAN ORIENTATION

All Davies Craig Thermatic Fans have reverse polarity and the fan blade can be easily installed for either **upstream** (in front of radiator) or **downstream** (on the engine side of the radiator) operation. When they leave the factory, they are set for upstream.

D. INSTALLATION OF FANS

- (i) MOUNTING OF FAN ASSEMBLY.
- (ii) FAN WIRING.

(i) MOUNTING OF FAN ASSEMBLY

Please pay particular attention to the markings on the fan hub regarding the direction the fan should face. The Thermatic Fan fitting instructions must be closely followed, regardless of whether the unit is mounted upstream or downstream.

Please note the direction of the arrow on the hub/blade as once the fan is installed the arrow may not be visible.

Position the unit directly on the face of the radiator/condenser. Take care that the fan and shroud does not foul any struts, engine pulleys, bonnet latches etc., including when the bonnet is closed.

Depending on the space available and the presence of an AC condenser, you may prefer to remove the radiator from the vehicle to ease the fitting procedure.

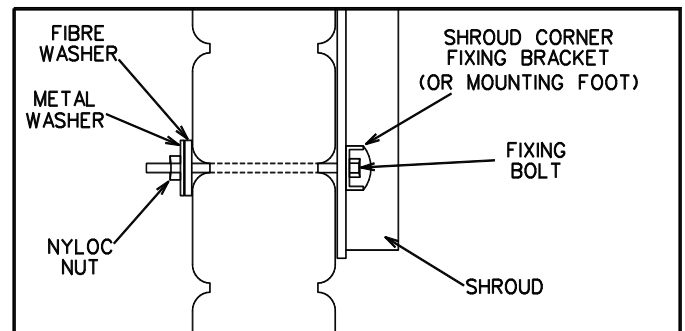

Separate the radiator fins at the four points where the mounting bolts are to be passed through the radiator between the tubes. Use a "Phillips head" screw-driver or very blunt instrument to separate the fins, being careful not to damage the tubes. Secure each fan to the radiator using the hardware provided. Ensure the long bolts, fibre, metal washers and nuts provided are placed in the correct position, as per above diagram.

Please use the appropriate fuse according to the below chart.

Fan Size	Voltage	Recommended Fuse (A)
8 " 9" 10" 12" 14"	12V	15A
14"HP & 16"	12V	30A
8 " 9" 10" 12" 14"	24V	7.5A
14"HP & 16"	24V	15A

If in any doubt or have any further queries please contact Davies, Craig direct on (03) 9369-1234 or info@daviescraig.com.au.

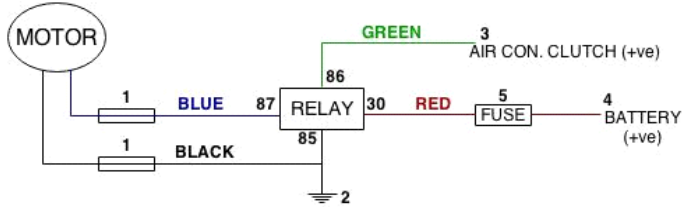

- 1 ONE FAN, CONDENSER ONLY**
- 1 BLUE CONNECTOR (FROM FAN KIT)
 - 2 SELF TAPPER (FROM FAN KIT)
 - 3 SCOTCHLOCK (FROM FAN KIT)
 - 4 RING TERMINAL (FROM FAN KIT)
 - 5 FUSE HOLDER & FUSE (FROM FAN KIT LOOM)
- PURCHASE: 1 FAN KIT**

WARNING: ENSURE IGNITION SOURCE IS NOT CONNECTED TO THE ENGINE MANAGEMENT SYSTEM

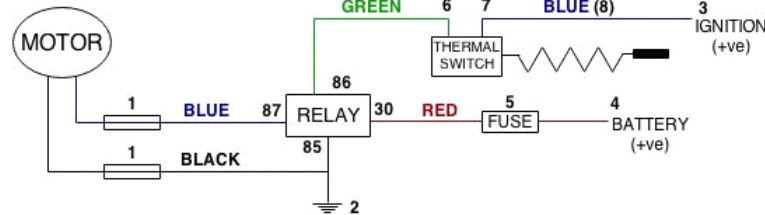

- 2 ONE FAN, THERMATIC ONLY**
- 1 BLUE CONNECTOR (FROM FAN KIT)
 - 2 SELF TAPPER (FROM FAN KIT)
 - 3 SCOTCHLOCK (FROM FAN KIT)
 - 4 RING TERMINAL (FROM FAN KIT)
 - 5 FUSE HOLDER & FUSE (FROM FAN KIT LOOM)
 - 6 FEMALE SPADE BLUE (FROM THERMAL SWITCHKIT)
 - 7 FEMALE SPADE BLUE (FROM THERMAL SWITCHKIT)
 - 8 COILED BLUE WIRE (FROM THERMAL SWITCHKIT)
- PURCHASE: 1 FAN KIT, 1 THERMAL SWITCH KIT P/NO: 0401**

WARNING: ENSURE IGNITION SOURCE IS NOT CONNECTED TO THE ENGINE MANAGEMENT SYSTEM

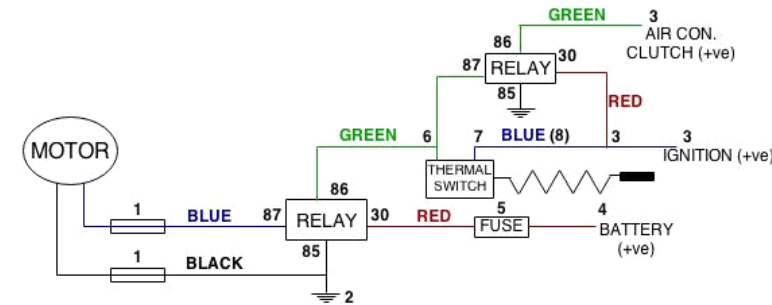

- 3 ONE FAN, CONDENSER AND / OR THERMATIC**
- 1 BLUE CONNECTOR (FROM FAN KIT)
 - 2 SELF TAPPER (FROM FAN & THERMAL SWITCHKIT)
 - 3 SCOTCHLOCK (FROM FAN & THERMAL SWITCHKIT)
 - 4 RING TERMINAL (FROM FAN KIT)
 - 5 FUSE HOLDER & FUSE (FROM FAN KIT LOOM)
 - 6 FEMALE SPADE BLUE (FROM THERMAL SWITCHKIT)
 - 7 FEMALE SPADE BLUE (FROM THERMAL SWITCHKIT)
 - 8 COILED BLUE WIRE (FROM THERMAL SWITCHKIT)
- PURCHASE: 1 FAN KIT, 1 THERMAL SWITCH & RELAY KIT P/NO: 0404**

WARNING: ENSURE IGNITION SOURCE IS NOT CONNECTED TO THE ENGINE MANAGEMENT SYSTEM

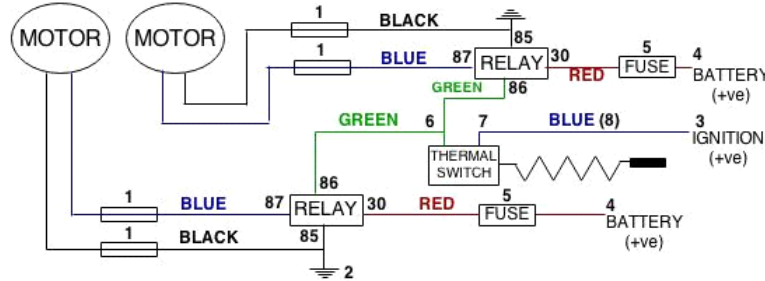

- 4 TWIN FANS, THERMATIC ONLY**
- 1 BLUE CONNECTOR (FROM FAN KITS)
 - 2 SELF TAPPER (FROM FAN KITS)
 - 3 SCOTCHLOCK (FROM FAN KITS)
 - 4 RING TERMINAL (FROM FAN KITS)
 - 5 FUSE HOLDER & FUSE (FROM FAN KITS)
 - 6 FEMALE SPADE BLUE (FROM THERMAL SWITCHKIT)
 - 7 FEMALE SPADE BLUE (FROM THERMAL SWITCHKIT)
 - 8 COILED BLUE WIRE (FROM THERMAL SWITCHKIT)
- PURCHASE: 1 FAN KIT, 1 THERMAL SWITCH KIT P/NO: 0401**

WARNING: ENSURE IGNITION SOURCE IS NOT CONNECTED TO THE ENGINE MANAGEMENT SYSTEM

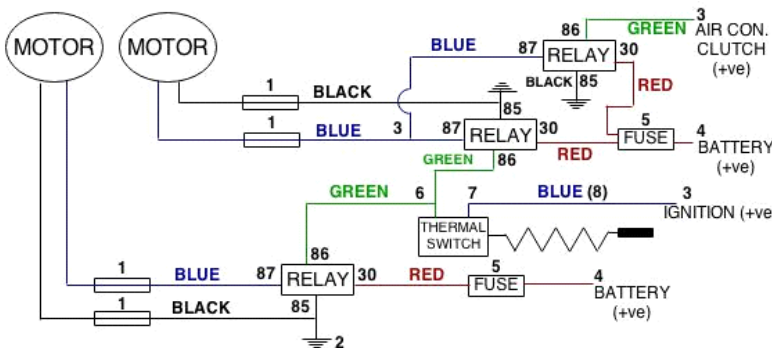

- 5 TWIN FAN, THERMATIC SINGLE FAN CONDENSER**
- 1 BLUE CONNECTOR (FROM FAN KITS)
 - 2 SELF TAPPER (FROM FAN & THERMAL SWITCHKIT)
 - 3 SCOTCHLOCK (FROM FAN KITS)
 - 4 RING TERMINAL (FROM FAN KITS)
 - 5 FUSE HOLDER & FUSE (FROM FAN KITS)
 - 6 FEMALE SPADE BLUE (FROM THERMAL SWITCHKIT)
 - 7 FEMALE SPADE BLUE (FROM THERMAL SWITCHKIT)
 - 8 COILED BLUE WIRE (FROM THERMAL SWITCHKIT)
- PURCHASE: 2 FAN KITS, 1 THERMAL SWITCH & RELAY KIT P/NO: 0404**

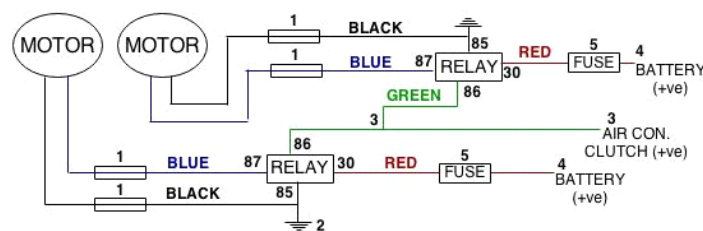

- 6 TWIN FANS, CONDENSER ONLY**
- 1 BLUE CONNECTOR (FROM FAN KIT)
 - 2 SELF TAPPER (FROM FAN KITS)
 - 3 SCOTCHLOCK (FROM FAN KITS)
 - 4 RING TERMINAL (FROM FAN KITS)
 - 5 FUSE HOLDER & FUSE (FROM FAN KITS)
- PURCHASE: 2 FAN KITS**

Note: Colour of motor leads depends on fan location (upstream/downstream)
If in doubt, refer to the rotation and polarity chart.

The two terminals on the thermal switch are equivalent. It does not matter which goes to the ignition and which goes to the relay. When the switch closes it connects the two terminals.