



Detroit Speed, Inc.
QUADRA Link Rear Suspension
1968-1974 Nova
P/N: 041704

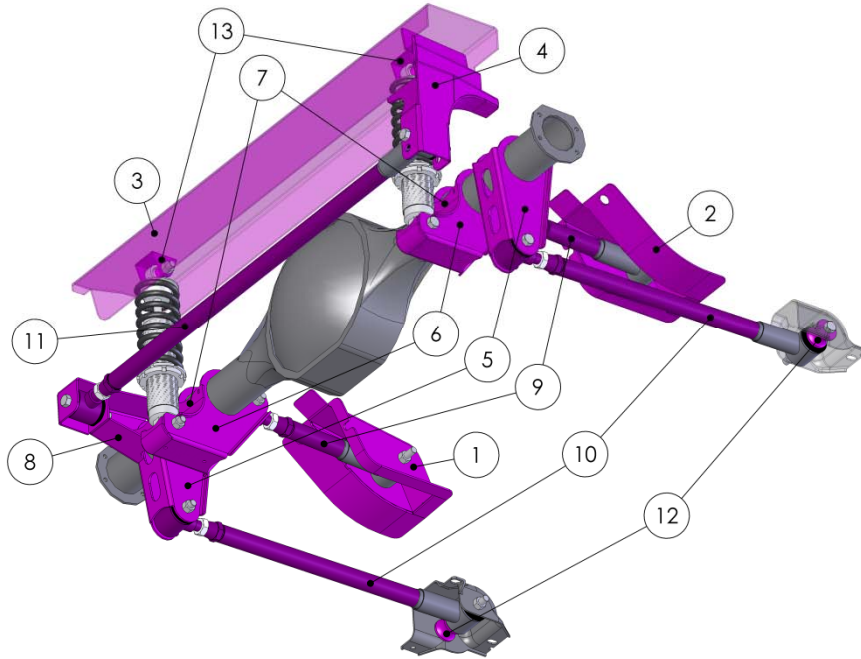

Figure 1

Item	Component	Quantity
1	Upper Link Front Pocket-Left	1
2	Upper Link Front Pocket-Right	1
3	Upper Shock Crossmember	1
4	Track Bar Body Mount Bracket	1
5	Lower Link Axle Mount Bracket	2
6	Upper Link/Coilover Axle Mount Bracket	2
7	Upper Link/Coilover Axle Bracket Reinforcement	2
8	Track Bar Axle Mount Bracket	1
9	Upper Link-Adjustable with Swivel-Link	2
10	Lower Link-Adjustable with Swivel-Link	2
11	Track Bar-Adjustable with Swivel-Link	1
12	Lower Link Front Spacer	2
13	Coilover Upper Shock Mount with 1/2"-13 x 3.0" Bolt & Nut Assembly	2
14	9/16"-18 x 3.75" Grade 8 Hex Head Bolt & Nylock Nut Assembly with 2 SAE Washers	8
15	9/16"-18 x 5.0" Grade 8 Hex Head Bolt & Nylock Nut Assembly with 2 SAE Washers	2
16	1/2"-20 x 3.5" Grade 8 Hex Head Bolt & Nylock Nut Assembly with 2 AN Washers	2
17	Spacer, 2.42" Long - For Fabrication Use Only	2
18	Upper Link Front Pocket Template	1

Introduction

Congratulations on your purchase of a QUADRA Link rear suspension from Detroit Speed and Engineering, Inc. This is a great way to upgrade from an original leaf spring rear suspension. DSE's exclusive new 4-link geometry design is uncompromised and designed to achieve the best possible handling during all conditions. The new DSE "Swivel-Link" (Patent pending) and tuned high-durometer rubber bushings allow the suspension to fully articulate with smooth silent motion and no binding. This is done without the use of heim-joints, which are noisy and prone to wear. The jam nuts on a typical adjustable bushed link have a tendency to come loose due to suspension bind when going over uneven surfaces (like pulling into a driveway). The Swivel-Links on the QUADRA Link suspension permit the links to pivot, thus eliminating bind and unwanted torsional loading of the jam nuts. The long suspension links provide excellent pinion and u-joint angle control. This system utilizes a long, horizontal panhard rod that provides precise and effective rear axle lateral location during hard cornering. The panhard rod is adjustable for roll center control at various ride heights, and the rear upper shock crossmember adds strength and rigidity to the rear body and frame section.

Installation Instructions

1. Before beginning the installation, read and comprehend the entire set of instructions.
2. Prepare the vehicle
 - a. Raise the vehicle a few feet off the ground so the interior, trunk and underside may be accessed. Insure that the vehicle is level and well supported.
 - b. Disconnect the negative battery cable.
 - c. Remove the rear suspension and axle.
 - d. Remove the fuel tank and lines.
 - e. Remove the seats, carpet and padding, rear interior quarter trim panels, and package tray. Any other interior panels, such as the headliner, door panels, etc., should be removed or masked well to protect them from grinding and welding sparks.
3. Install the upper link, front mounting pockets
 - a. Mark the location of the lower seat-back brackets and then remove them by carefully drilling out the spot welds. Set the brackets aside so they can be reinstalled after the upper link pockets have been installed. (Figure 2)

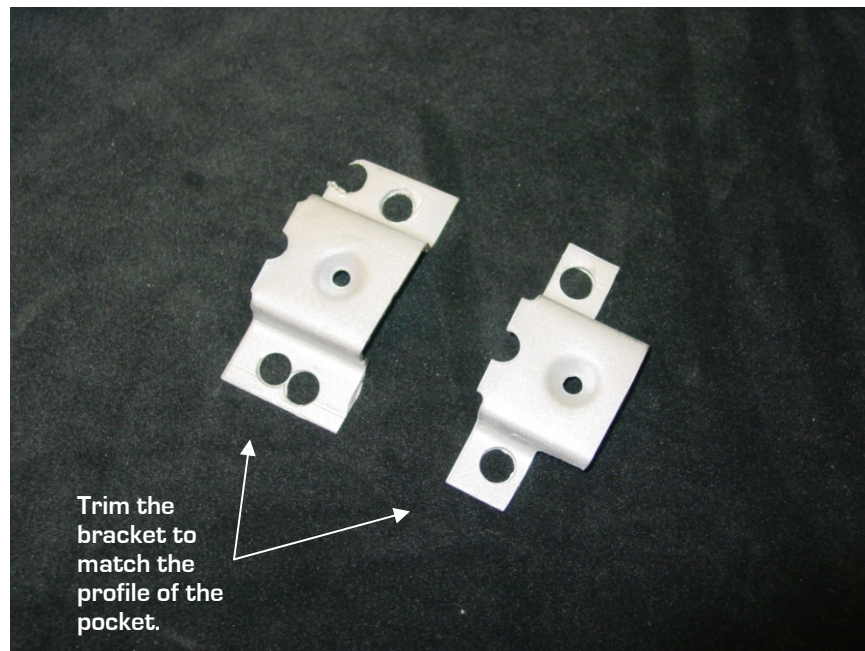

Figure 2

- b. Find the centerline of the vehicle. Measure from the inner rocker panel flanges across the vehicle at the front and rear of the floorpan as shown in Figure 3. Divide these measurements by two and mark the centerline line on the transmission tunnel. **Note:** The vehicle's centerline will not coincide with the transmission tunnel centerline. The transmission tunnel is offset to the passenger side slightly. The measurement between the inner rocker and vehicle centerline should be between 23-13/16" and 23-7/8".



Figure 3

- c. Place the upper link pockets in the rear seat area where they will be installed. Fit them to the floor pan and place them so that there is 13 3/8" inches between the inside of the pocket and the vehicle centerline. The centerline of the pocket (not flange) to vehicle centerline distance should be 14 3/4" as shown in Figure 4.



Figure 4

- d. Once the pockets are in their location, take a marker and trace along the outer edge of the pockets. (Figure 5)



Figure 5

- e. Remove the link pockets from the vehicle. Now, cut out the upper link mounting pocket template, align the arrows, and position it in the outline traced in the previous step. The hole in the template lines up with the rear seat belt mounting hole (on early Nova's only). The template should run parallel to the rear framerail as shown in Figure 6. Outline the area to be cut, remove the template, turn it over, and then repeat the procedure on the left side of the vehicle.

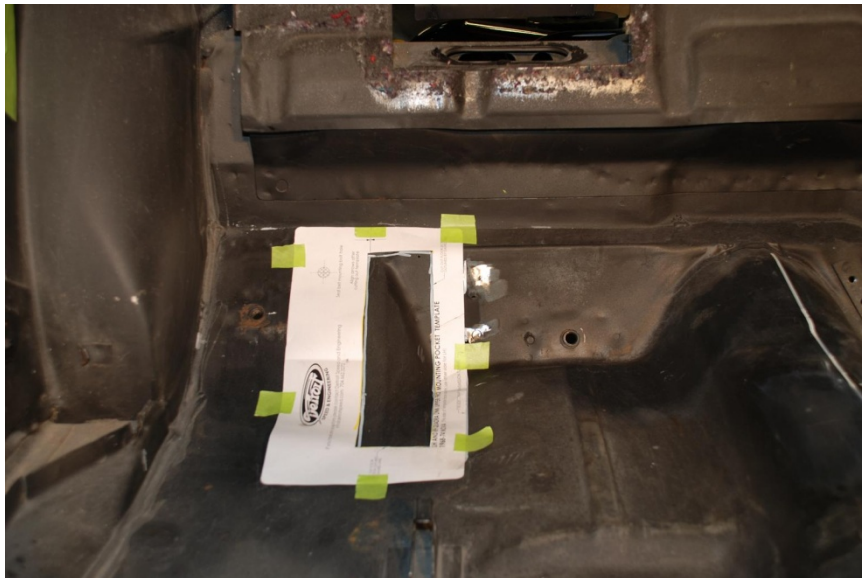

Figure 6

- f. Once you have the area to be removed marked, drill a 1/8" hole into each corner before you cut. This is to double check that the link pocket will be positioned just inside the framerail. Check the holes from the bottom of the vehicle to insure you do not cut into the framerail. However, a small portion of the frame rail flange may need to be removed.

- g. If the cutout area is correctly marked, remove the material using a cut-off wheel. (Figure 7)



Figure 7

- h. The inboard edge of the cut out floorpan on the passenger side will need to be flattened out about one inch, so that it has a similar contour to the driver's side floorpan. (Figure 8)

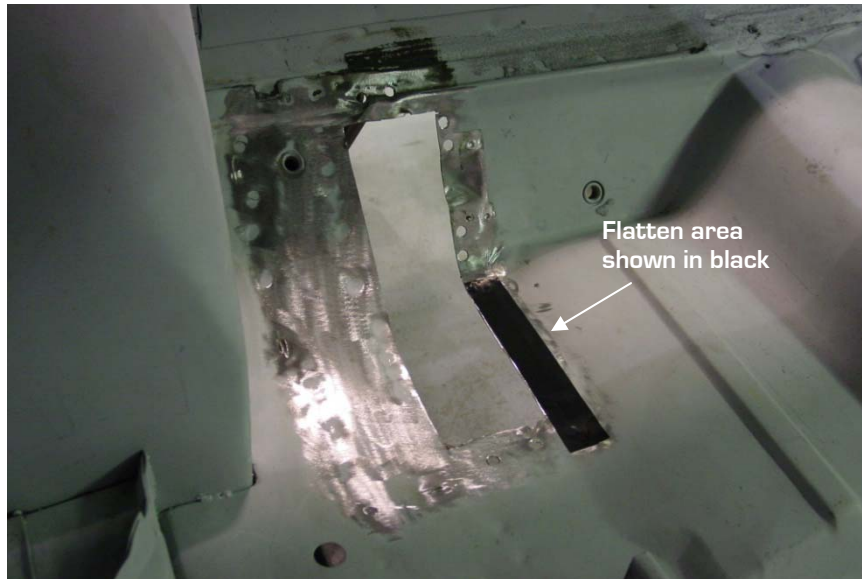

Figure 8

- i. Fit the upper link mounting pockets. Insert the rear flange of the pocket through the hole and position it under the welded seam at the rear of the floorpan as shown in Figure 9 and Figure 10. The remainder of the pocket flange will sit on the floor inside the vehicle, and the hole will line up with the rear seat belt bolt as illustrated in Figure 10 (early Nova's only). Due to variations between vehicles and floorpan types, additional material may need to be trimmed. It may also be necessary to form the floorpan and/or mounting pocket flange to obtain the best fit.



Figure 9



Figure 10

- j. Once the mounting pockets are properly fit to the vehicle, drill two rows of holes (approximately 5/16" in diameter) in the outboard flange of the mounting pocket in line with the frame rail flange under the floor as shown in Figure 11. This will allow the pockets to be plug welded to the top of the frame rail.



Figure 11

- k. Make sure the pocket's centerline distance is $14 \frac{3}{4}$ ". Repeat this step on the other side. The center to center distance from pocket to pocket should be $29 \frac{1}{2}$ " to coincide with the bracket spacing on the rear axle.
- l. Tack weld the mounting pockets in place, then double check their position and fit. They should be square and plum to the vehicle and each other.
- m. Weld the mounting pockets in place. Pockets should be plug welded to the frame rails, and stitch welded around the perimeter of the flange. Make sure to also weld the floor pan to the pockets from the underside of the vehicle.
- n. Modify the original lower seat back brackets similar to the one shown in Figure 1, and weld the modified brackets back in their original positions as shown in Figure 12.



Figure 12

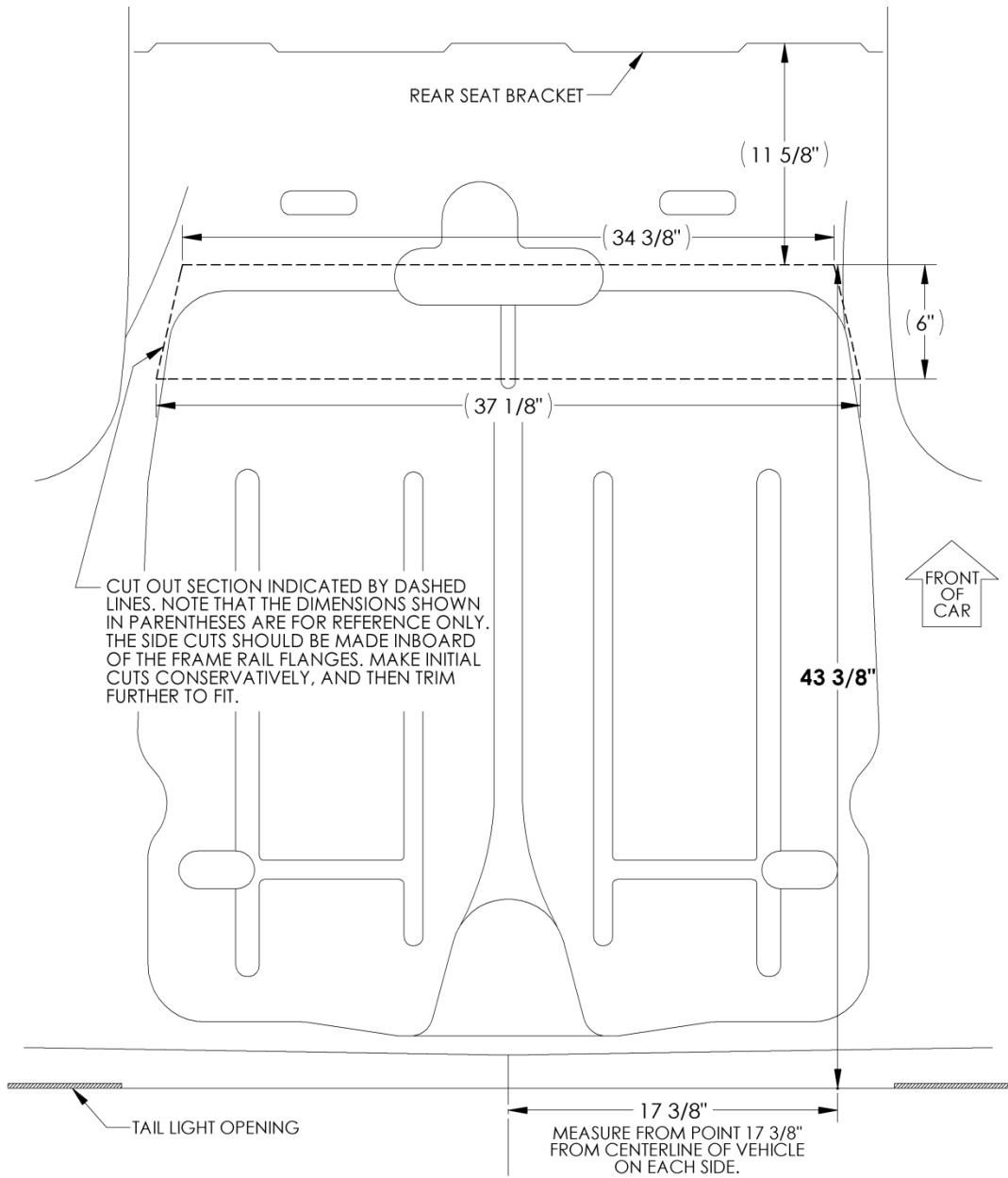

Figure 13

4. Install the upper shock crossmember
 - a. Cut the area in the trunk floor between the rear tires for the upper shock crossmember as shown in Figure 13. The measurement points are 17 3/8" from the centerline of the vehicle in the lower corner of the tail light panel where it meets the trunk floor as illustrated in Figure 14.
 - b. Fit the crossmember in the cut out area. Position it so the longer flange is toward the rear of the vehicle. It will sit on the trunk floor right above the rear frame rails; this will locate it at the correct height. The crossmember should be level in the horizontal plane and straight fore/aft from the rear of the vehicle.
 - c. Tack weld the crossmember in place and verify that it is positioned correctly.



Figure 14

- d. Trim the front and rear edges of the crossmember to match the profile of the floor pan if necessary.
- e. Weld the crossmember in position.
- f. Install closeouts made from 1/8" steel at each end of the crossmember above the frame rails under the vehicle in the area shown in Figure 15. Dimensions will vary between vehicles, so templates are not included.



Figure 15

5. Install the track bar body mount bracket
 - a. Position the track bar body mount bracket against the bottom and inside of the right rear framerail. It should also be aligned inside the upper shock crossmember as shown in Figure 16. The bolt holes should be level and parallel to the centerline of the vehicle.



Figure 16

- b. Tack weld the track bar body mount, then double check its position and fit.
 - c. Weld the track bar body mount bracket in place.
6. Install the axle brackets
- a. It is recommended that the axle brackets are installed when the axle tube flanges are not on the axle. If a new axle is being installed or the existing axle is being narrowed, install the axle brackets first, and then install the flanges. If the flanges are not removed, cut the axle brackets apart and weld them back together around the axle tube.
 - b. It is important that the correct width for the bushings is maintained on the axle brackets when they are welded; therefore, the spacers provided with the kit should be installed in the brackets in these areas during welding. Position the axle brackets on the axle tubes as shown in Figure 22. If the axle brackets were cut during installation, the upper link/coilover bracket reinforcements should be welded on after the upper link/coilover brackets are welded to the axle, but the reinforcements should be kept on as much as possible during welding to maintain correct alignment. If the axle brackets were not cut for installation, it may be easier to weld the upper link/coilover bracket reinforcements in place before welding the axle brackets to the axle. The track bar axle bracket attaches to the left lower link axle bracket and will be installed later. **NOTE:** Detroit Speed offers a pinion centering tool (P/N 070202) that will be helpful in placing your axle brackets in the correct location on your axle tube.
 - c. Tack weld the brackets in place, and then verify that they are all positioned correctly. Weld the brackets securely in place.
 - d. Install and weld the upper link/coilover reinforcement brackets as shown in Figure 22 if not done previously.
 - e. The track bar axle bracket mounts on the rear of the driver's side lower link bracket as shown in Figure 22. The left side of the bracket lines up with the left side of the link bracket and is square to the axle tube.
 - f. Tack weld the track bar axle bracket in place, verify its position, and then weld it to the other bracket.
 - g. Once all of the axle brackets are fully welded in place, remove the spacers, and check the axle for straightness.
7. Install the upper shock mount brackets
- a. Position the rear axle in place under the vehicle and install the links as shown in Figure 1. **NOTE:** Do not tighten the bolts at this time. The 9/16"-18 x 5" bolts for the front of the lower links mount with the included spacers through the stock front leaf spring brackets once the holes have been enlarged with a 37/64" diameter drill bit. Support the axle at ride height. Check the axle position in the vehicle and adjust the end links as necessary.

- b. Install the upper shock mounts on the shocks and mount the shocks in the axle brackets without the springs (no need to tighten the bolts at this time). Position the shocks as vertical as possible making sure to leave enough clearance so the shocks and springs do not interfere with anything during full axle travel. Mark the upper shock mount locations.
 - c. Remove or shield the shocks and axle assembly and weld the upper shock mount brackets in place.
 8. Verify the installation
 - a. At this point the fabrication work is complete. Send the axle to a qualified shop to have the ends welded (if necessary).
 - b. Check the axle tubes for straightness and have them straightened (if needed).
 - c. Mocking up the vehicle before painting all of the components is recommended. Mock up includes installing all of the suspension components (the link bolts still don't need to be tightened yet) installing the wheels/tires, and resting the vehicle on all four tires. Double check that the rear axle is positioned correctly in the vehicle. It should be centered from side to side, and the wheelbase should be correct on both sides of the vehicle (111.0" for a 1968-74 Nova). The pinion angle should be measured and adjusted to your preference. Two degrees down is recommended. Raise and lower the vehicle to verify that there is no interference.
 - d. On some vehicles the rear seat cushion frame may need to be modified in order to clear the upper link pockets. Modify the seat frame if needed.
 - e. Paint or coat the components as desired.
 9. Final assembly and adjustments
 - a. Install the rear axle and suspension assembly; the end link bolts will be tightened later with the vehicle sitting at ride height.
 - b. Reinstall the fuel tank, fuel lines, and interior components that were removed. The rear seat back may be installed, but do not install the rear seat cushion in the vehicle at this time. Place the rear seat cushion in the vehicle so it will be at the correct weight during adjustments. The rear seat cushion will not be installed until after the upper link bolts are tightened.
 - c. Install the wheels on the vehicle and lower it onto the ground.
 - d. Verify that the track bar is installed in the hole that places it closest to horizontal.
 - e. Position the axle in the vehicle by adjusting the end links. **NOTE: There can be no more than 1 1/4" of exposed threads on the end link (3/4" of thread engagement in the tube). This measurement does not include the jam nut.** It should be centered from side to side, the wheelbase must be correct on both sides of the vehicle, and the pinion should be adjusted to the desired angle. Once the axle is in the proper position, torque the end link jam nuts to 100 ft-lbs.
 - f. Bounce the vehicle a few times and then torque all of the rear suspension link pivot bolts to 120 ft-lbs with the vehicle sitting at ride height.
 - g. Torque the coilover mounting bolts to 80 ft-lbs with the vehicle sitting at ride height.
 - h. Confirm the axle position again. Double check that all of the bolts and jamb nuts are tightened to their respective torque specifications.
 - i. Install the rear seat cushion.
 10. Setting the vehicle ride height.
 - a. With the vehicle assembled with all components installed, adjust the ride height as necessary. Detroit Speed does recommend using a small wipe of anti-seize before adjusting the spanner nut and compressing the coilover spring.
 - b. Detroit Speed does include a Spanner Tool (P/N: 031060) to adjust ride height however if you have the adjustable coilover shocks, Detroit Speed does offer an Adjustment Tool available as P/N: 031061 if needed. A photo can be seen in Figure 17.



Figure 17 - DSE Spanner & Adjustment tools

11. If the Single Adjustable, Double Adjustable or the Double Adjustable Remote Canister Coilovers were purchased as an upgrade, refer to the following information for adjustment procedures.

**PLEASE NOTE: ALL ADJUSTABLE TYPE SHOCKS GET MOUNTED BODY SIDE UP
SHAFT SIDE DOWN**

DSE Single Adjustable Shock Applications

To change from the recommended “Detroit Tuned” valving, adjustments can be made independently to the rebound setting. The rebound is controlled by the knob at the lower shock mount (Shock is mounted body side up). The knob rotates clockwise (+) to increase the damping and counterclockwise (-) to decrease the damping. Refer to Figure 18a below

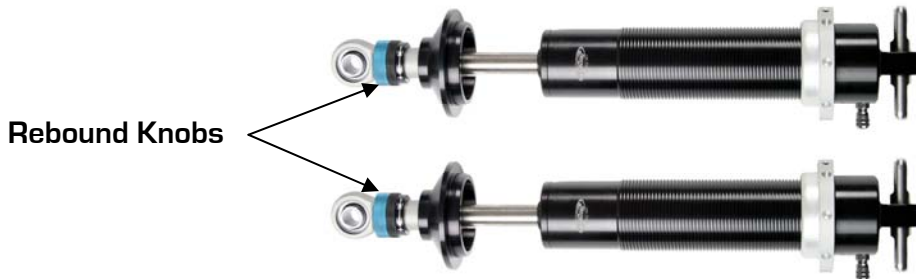

Figure 18a - DSE Single Adjustable Shock

To return to the DSE recommended settings, turn the knob clockwise (+) to full damping. Once at full damping, turn counterclockwise (-) to reach the recommended settings. Refer to Figure 18b for the rebound settings.

Rebound (Shaft Knob)..... 20 Open (counterclockwise, -)

Figure 18b - DSE Recommended Settings

Adjuster Operation

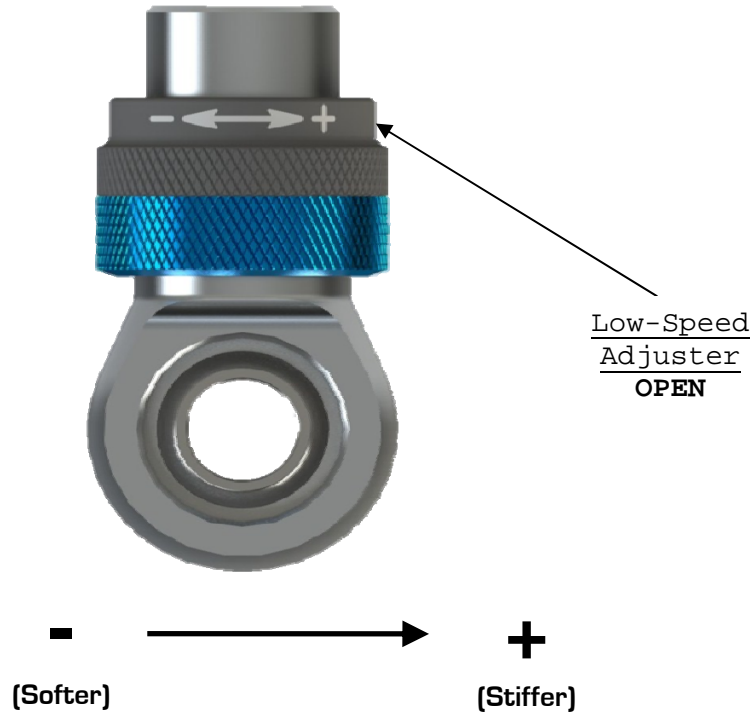

- **Adjuster (60-64 Clicks)**

The low-speed adjuster is a “clicker” style adjuster meaning that its adjustment is measured by detents located inside the blue adjuster knob. There are 16 clicks per 1 revolution of the knob. It uses a right-hand thread in its operation which means as you increase low-speed, the adjuster will move up on the eyelet. The recommended change for an adjustment is 8 clicks at a time. The low-speed adjuster’s reference position is **full stiff** (closed, or all the way up) and referred to -0 (-0 = full stiff, -64 = full soft).

- **Tuning Notes**

- **Racetrack**

- For more grip, soften the damping.
- For increased platform control, stiffen the damping.

- **Street**

- For a more comfortable ride, soften the damping

***DO NOT FORCE KNOB WHEN IT STOPS TURNING, YOU MAY DAMAGE THE ADJUSTER AND INTERNAL HARDWARE**

DSE Double Adjustable Shock Applications

To change from the recommended “Detroit Tuned” valving, adjustments can be made independently to both the high and low speed settings. The rebound is controlled by the sweepers at the lower shock mount. The sweepers rotate clockwise (+) to increase the damping and counterclockwise (-) to decrease the damping. The sweepers can be seen in Figure 19a.



Figure 19a - DSE Double Adjustable Shock

When adjusting the low speed rebound start at full (+) position, when adjusting the high speed rebound start at full (-) position. To return to the DSE recommended settings turn the sweeper clockwise(+) to full damping for the low speed setting, and counterclockwise (-) to full damping for the high speed setting. Once at full damping, turn counterclockwise(-) for the low speed setting, and clockwise(+) for the high speed setting to reach the recommended settings. Refer to Figure 19b for recommended settings.

Low Speed Rebound (Sweeper)..... 20 sweeps (counterclockwise)(-)
 High Speed Rebound (Sweeper)..... 2 sweeps(clockwise)(+)

Figure 19b - DSE Recommended Settings

DSE Double Adjustable Shocks w/Remote Canisters

To change from the recommended “Detroit Tuned” valving, adjustments can be made independently to both the high and low speed settings. The rebound is controlled by the sweepers at the lower shock mount. The sweepers rotate clockwise (+) to increase the damping and counterclockwise (-) to decrease the damping. Refer to Figure 20a.

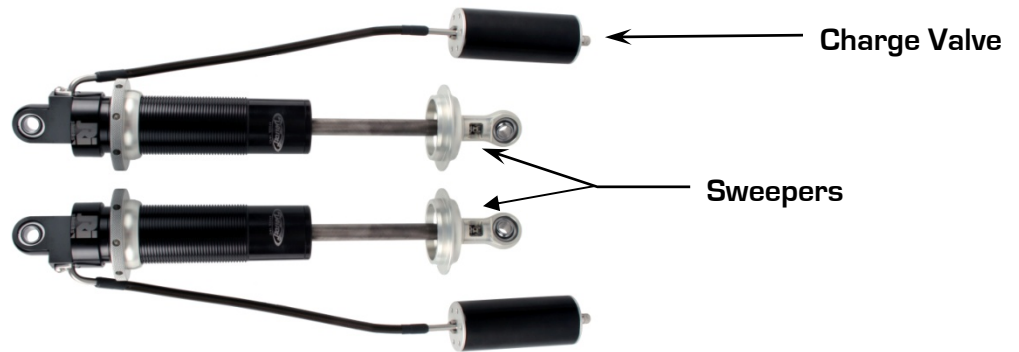

Figure 20a - DSE Double Adjustable Shock w/Remote Canister

When adjusting the low speed rebound start at full (+) position, when adjusting the high speed rebound start at full (-) position. To return to the DSE recommended settings turn the sweeper clockwise(+) to full damping for the low speed setting, and counterclockwise (-) to full damping for the high speed setting. Once at full damping, turn counterclockwise(-) for the low speed setting, and clockwise(+) for the high speed setting to reach the recommended settings. Refer to Figure 20b for recommended settings.

Low Speed Rebound (Sweeper)..... 20 sweeps (counterclockwise)(-)
 High Speed Rebound (Sweeper)..... 2 sweeps(clockwise)(+)

Figure 20b - DSE Recommended Settings

Adjuster Operation

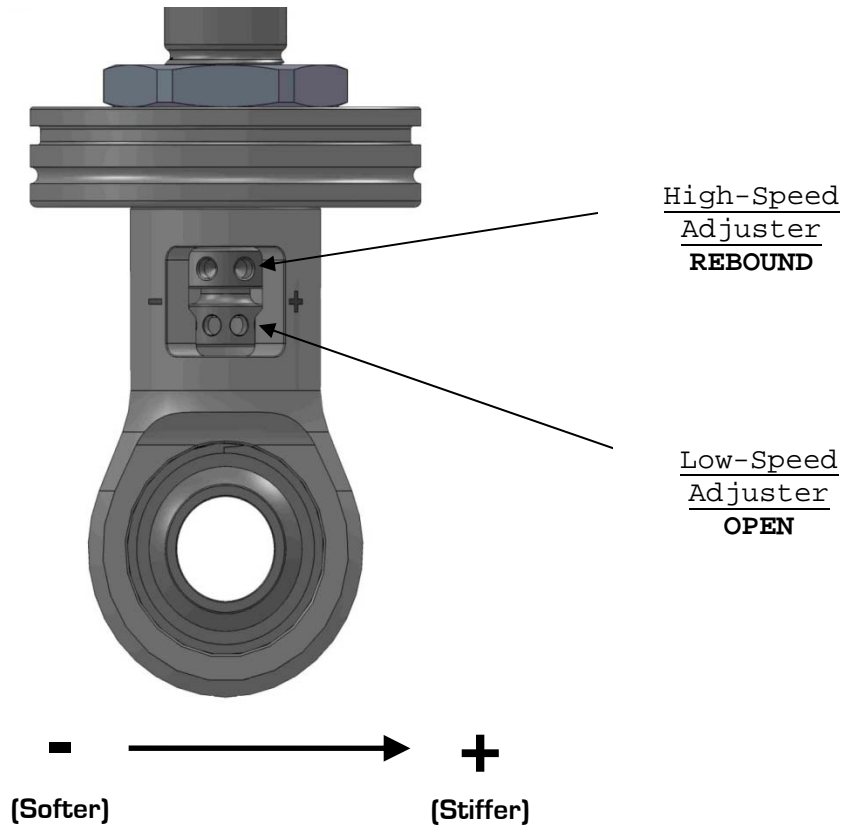

- **High-Speed Adjuster (12 Sweeps)**

The high-speed adjuster is a “sweep” style adjuster meaning that its adjustment is measured by the location of the adjuster in the eyelet window. It uses a left-hand thread in its operation which means; as you increase high-speed, the adjuster will move down in the window*. The high-speed adjuster’s reference position is **full soft** and referred to as +0 (+0 = full soft, +12 = full stiff).

- **Low-Speed Adjuster (25 Clicks)**

The low-speed adjuster is a “clicker” style adjuster meaning that its adjustment is measured by detent grooves located inside the high-speed shaft. It uses a right-hand thread in its operation which means; as you increase low-speed, the adjuster will move up in the window. The low-speed adjuster’s reference position is **full stiff** and referred to -0 (-0 = full stiff, -25 = full soft).

**The low-speed adjustment does not change when adjusting the high-speed.*

To aid in the installation of the reservoirs, we also offer a set of Billet Aluminum Remote Canister Mounts. The canister mounts are available exclusively through DSE, P/N: 032102. They are shown in Figure 21.



Figure 21 - Billet Aluminum Remote Canister Mounts

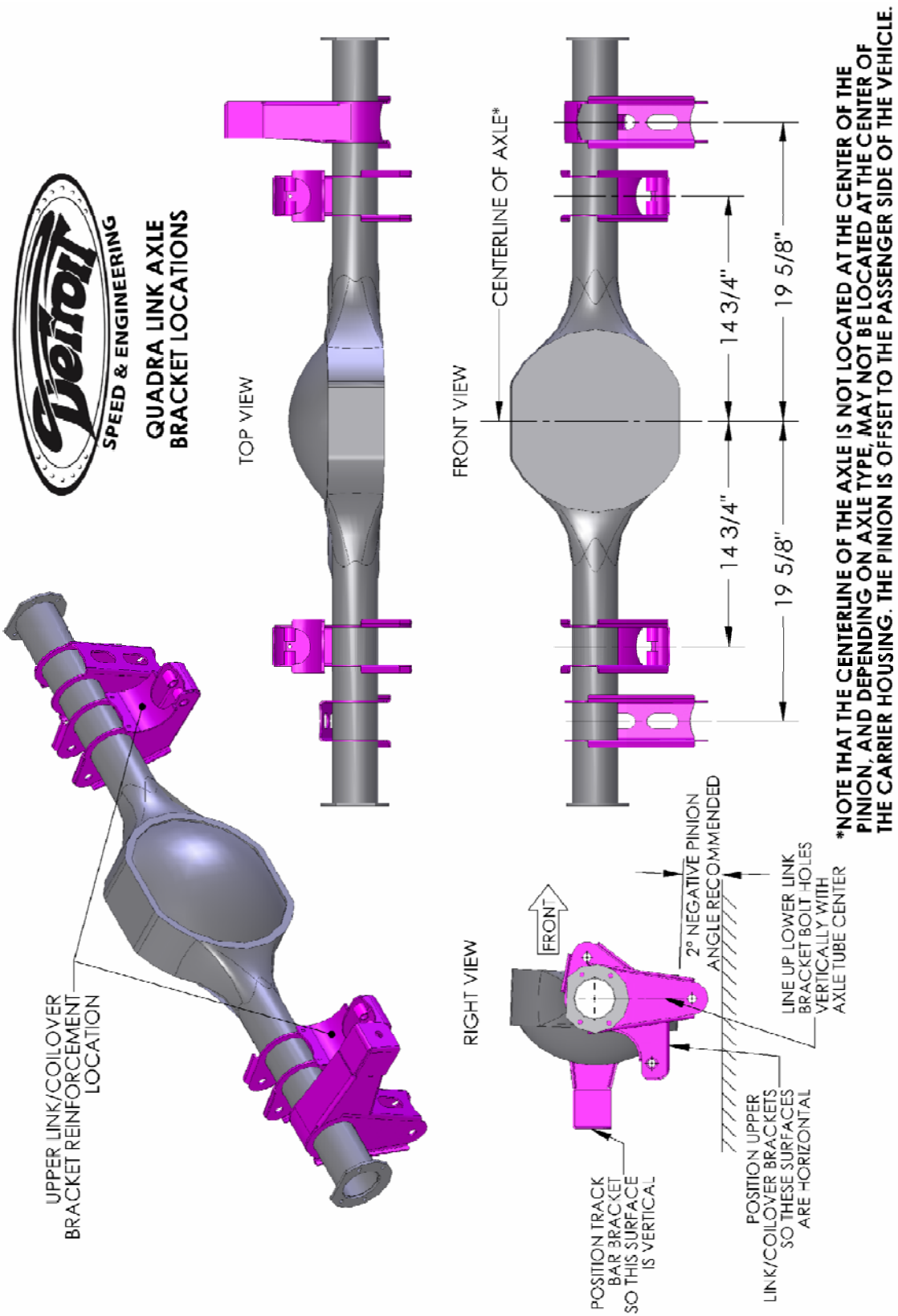

Figure 22

If you have any questions, please call Detroit Speed at (704) 662-3272.

Legal Disclaimer: Detroit Speed, Inc. is not liable for personal, property, legal, or financial damages from the use or misuse of any product we sell. The purchaser is solely responsible for the safety and performance of these products. No warranty is expressed or implied.