

## FRONT FENDER FLARE INSTALLATION INSTRUCTIONS

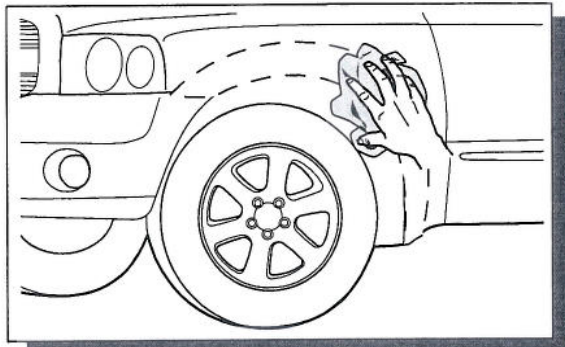

1. Wash the areas of contact on the vehicle and wipe dry both the vehicle and the Fender Flare with a clean cloth. Ensure inside of Fender Flare where extrusion is attached is clean.  
**NOTE:** Do not install edge extrusion until the parts are painted.

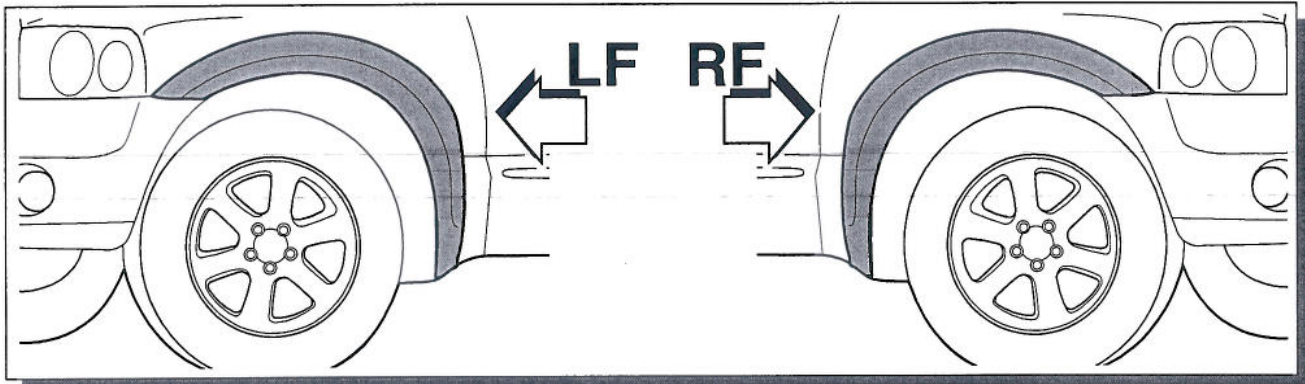
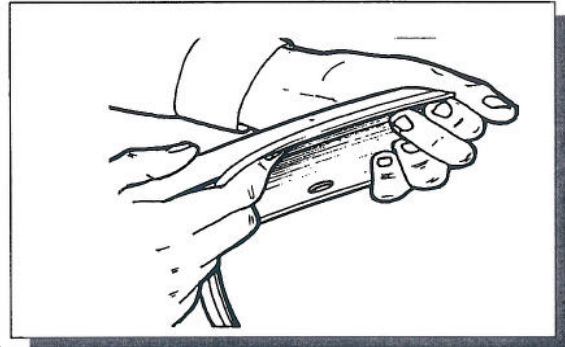

2. Remove approximately 50mm (2") of the protective liner from the extrusion. Fit the extrusion to the Fender Flare along the edge that comes in contact with the vehicles body panel.

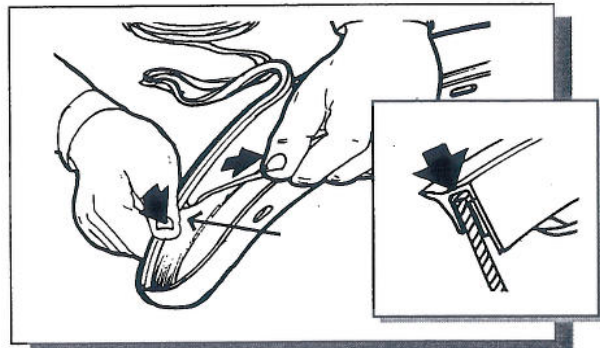

3. Pulling at right angles from the extrusion remove the liner from the extrusion in small portions and apply thumb pressure to ensure that it adheres to the Fender Flare.

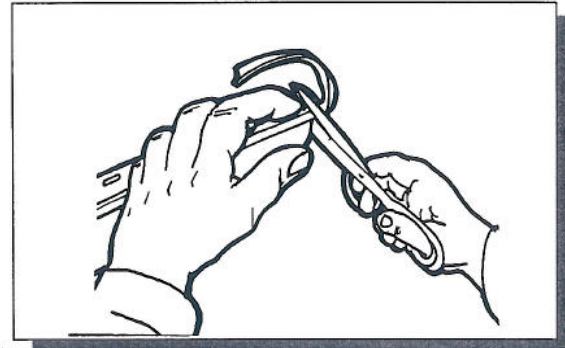

4. Trim excess extrusion and discard.

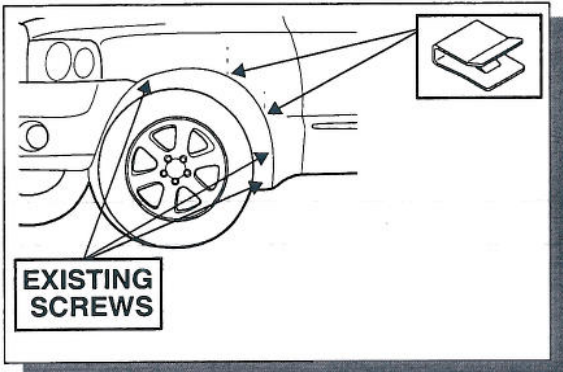

5. Note the correct hardware and existing screws position as shown. Also note the clips position.

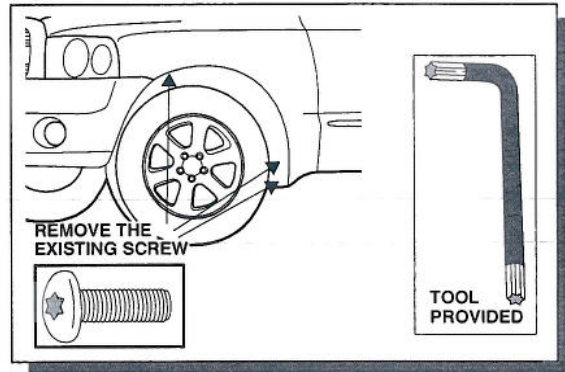

6. Remove the existing screws on vehicle as previously noted, using the tool provided.

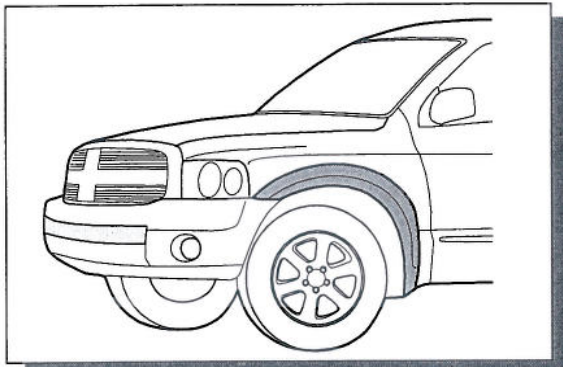

7. Fit the Fender Flare and align it with the existing screw positions. Secure the Fender Flare to vehicle by replacing the existing screws.

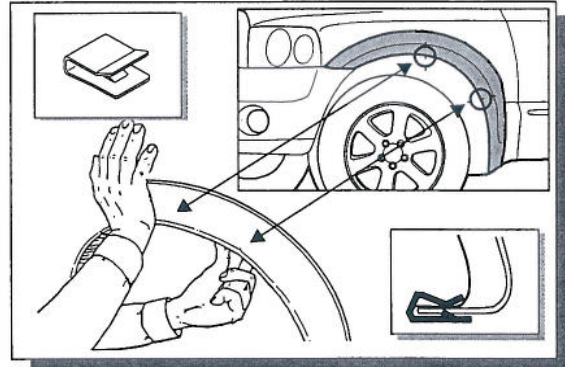

8. Take the supplied clips and insert them at the positions shown.



Clean Fender Flare using mild detergents only.  
Do not use abrasive cleaners