



INTAKE MANIFOLD GASKET
(For Honda D16Y8 Engines)
Catalog #15005
INSTALLATION INSTRUCTIONS

PLEASE study these instructions carefully before installing your new Edelbrock Intake Manifold Gasket. If you have any questions or problems, do not hesitate to contact our Technical Hotline at: 1-800-416-8628, from 7am-5pm, Monday-Friday, Pacific Standard Time or via e-mail at: Edelbrock@Edelbrock.com. Please fill out and mail your warranty card.

- Description: This is a replacement intake manifold gasket, which is supplied in the catalog #1500 turbo kit, as well as the intake manifold kits, #4754 & #4756.

KIT CONTENTS	
Qty.	Description
1	Intake Manifold Gasket

Installation Procedure

1. Remove the intake manifold as shown in your instructions for part #1500, #4754, or #4756.
2. Clean all gasket mating surfaces. Stuff paper towels into the open intake ports before cleaning to prevent any debris from entering the engine.
3. Re-install the intake manifold as shown in the #1500 or #4756 instructions, using the new gasket. If your vehicle was not equipped with air injection, trim the top edge of the gasket (See Fig. 1).
4. Torque all intake manifold bolts to 17 ft./lbs., following the sequence below (See Fig. 2).

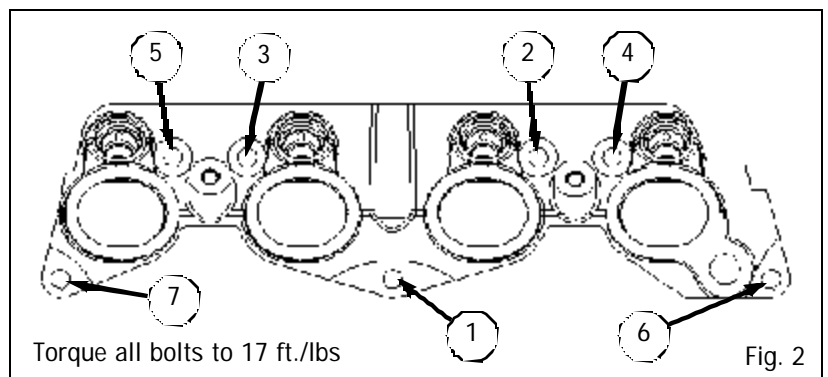
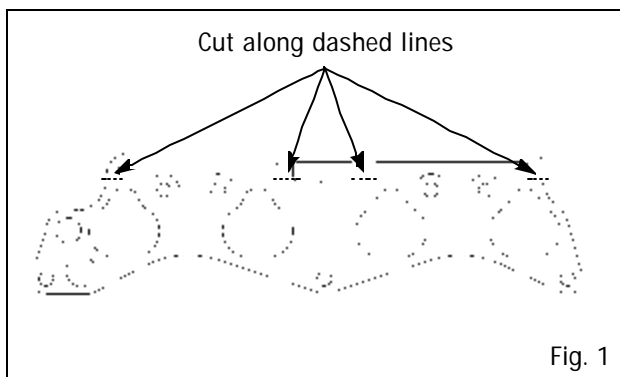

Edelbrock Corporation
2700 California St.
Torrance, CA 90503
Tech Line: 1-800-416-8628
Office: (310) 781-2222
E-Mail: Edelbrock@Edelbrock.com