



**PERFORMER FORD 400 INTAKE MANIFOLD**  
**For 351-M/400 Ford Cleveland Engines**  
**Catalog #2171**

**INSTALLATION INSTRUCTIONS**

**PLEASE** study these instructions carefully before beginning this installation. Most installations can be accomplished with common tools and procedures. However, you should be familiar with and comfortable working on your vehicle. If you do not feel comfortable performing this installation, it is recommended to have the installation completed by a qualified mechanic. If you have any questions, please call our **Technical Hotline at: 1-800-416-8628**, 7:00 am - 5:00 pm, Pacific Standard Time, Monday through Friday or e-mail us at [Edelbrock@Edelbrock.com](mailto:Edelbrock@Edelbrock.com).

**IMPORTANT NOTE: Proper installation is the responsibility of the installer. Improper installation will void your warranty and may result in poor performance and engine or vehicle damage.**

**DESCRIPTION:** Edelbrock Performer intake manifolds are designed for street-performance Ford 351-M/400 engines operating in the idle-5500 rpm range. Edelbrock Performer manifolds are designed to replace the stock manifold and to accept stock parts in most cases, as long the OEM or a recommended carburetor is retained, making an Edelbrock manifold installation among the simplest of bolt-on conversions. This intake manifold is part of a Total Power Package that can be completed with the use of dyno-matched Performer-Plus camshaft #2172, springs, chain set, carburetors and related parts specifically designed to give you maximum results. Please refer to the Edelbrock catalog to select all the components you need.

**KIT CONTENTS:**

- 1 Edelbrock #2732 square-bore gasket and steel plate
- 1 24" length of 3/8" vacuum hose
- 1 Vacuum tee

- **ACCESSORIES & INSTALLATION ITEMS:** Major recommendations are listed below. See our catalog for details. **To order a catalog, call (800) FUN-TEAM**, or visit [www.edelbrock.com](http://www.edelbrock.com).
- **EGR SYSTEMS:** Intake manifold will not accept stock EGR (Exhaust Gas Recirculation) equipment. EGR systems are used on most 1972 and later model vehicles. Check local laws for requirements.
- **CARBURETOR RECOMMENDATIONS:**

CARBURETOR	CHOKE TYPE	PARTS REQUIRED FOR INSTALLATION
<b>Performer #1405 (600 cfm)</b>	Manual	#1493 or 1847 throttle plate kit, #1483 or 1844 throttle lever adapter
<b>Performer #1406 (600 cfm)</b>	Electric	#1493 or 1847 throttle plate kit, #1483 or 1844 throttle lever adapter
<b>Performer #1805 (650 cfm)</b>	Manual	#1493 or 1847 throttle plate kit, #1483 or 1844 throttle lever adapter
<b>Performer #1806 (650 cfm)</b>	Electric	#1493 or 1847 throttle plate kit, #1483 or 1844 throttle lever adapter
<b>Thunder Series #1805 (650 cfm)</b>	Manual	#1493 or 1847 throttle plate kit, #1483 or 1844 throttle lever adapter
<b>Thunder Series #1806 (650 cfm)</b>	Electric	#1493 or 1847 throttle plate kit, #1483 or 1844 throttle lever adapter

**NOTES:** Carburetor size (CFM) should be selected based on your specific engine combination. Consult your engine builder or contact our Technical Hotline at: 1-800-416-8628 for assistance. Carburetors require a #8008 or #8024 stud, washer and nut kit; determine proper length based on gasket thickness and your accessory mounting requirements (See catalog for details). If a manual choke Performer Series Carburetor is used and electric choke is desired later on, Performer Series carburetors can be converted to electric choke using Electric Choke Kit #1478. Manual choke Thunder Series carburetors CAN NOT be converted to manual choke.

- **GASKETS:** Do not use competition-style intake gaskets for this street manifold. Due to material deterioration over time, internal leakage of vacuum, oil, and coolant may occur.

INTAKE MANIFOLD	REFERENCE	RECOMMENDED GASKET
<b>2171</b>	(None)	Edelbrock #7265 Port: 1.52" x 2.16", .060" Thickness

**NOTE: To ensure maximum performance and a proper seal, Edelbrock gaskets which are specifically designed and manufactured for use with Edelbrock parts must be used.**

- **THROTTLE BRACKETS:** The throttle and kickdown bracket on some vehicles may require modification to fit. When using Edelbrock carburetors, use #1493 or 1847 throttle plate kit to line up the stock throttle bracket to the Edelbrock carburetor throttle lever.
- **CARBURETOR PLATES AND GASKETS:** Installation of Edelbrock square-bore based carburetor requires Edelbrock square-bore carburetor adapter #2732 (supplied). Use the manufacture supplied carburetor gasket on top of the #2732 kit (**See Figure 1**).
- **SPECIAL INSTRUCTIONS:** Charcoal purge canister and PCV hose on later model vehicles connects to the front of the OEM intake manifold. The charcoal purge canister vacuum hose will have to be connected with the 3/8" PCV hose. The PCV hose will have to be rerouted to the side of the Holley carburetor. (**See Figure 2**).

**NOTE:** Pipe fittings on the front of the intake are not for coolant.

• **PREP AND TUNING FOR POWER:**

1. Due to design, the fuel / air mixture and cylinder charging is very efficient with Performer manifolds. Generally speaking, the stock jetting for a Performer Series or Thunder Series carburetor will not need changing. Specific applications may show an increase in power by tuning the fuel mixture.
2. Performer manifolds deliver excellent driveability and power utilizing the factory OEM distributor settings. Specific applications may benefit from resetting the initial timing + or - 2° from the factory specifications. Aftermarket distributor curve kits may be used with Performer series intake manifolds.
4. Installation of aftermarket headers, camshafts or both with an Edelbrock Performer RPM series manifold may lean carburetor calibration. Should this condition occur, recalibrate with a richer jet.

- **CAMSHAFT AND HEADERS:** Performer Series manifolds are compatible with aftermarket camshafts and headers designed to work in the idle-5500 rpm range. Edelbrock has developed a dyno-matched, street-proven camshaft, Performer-Plus #2172, which is ground specifically for use with the Performer 400 intake manifold. Header primary tube diameter should be 1-5/8".

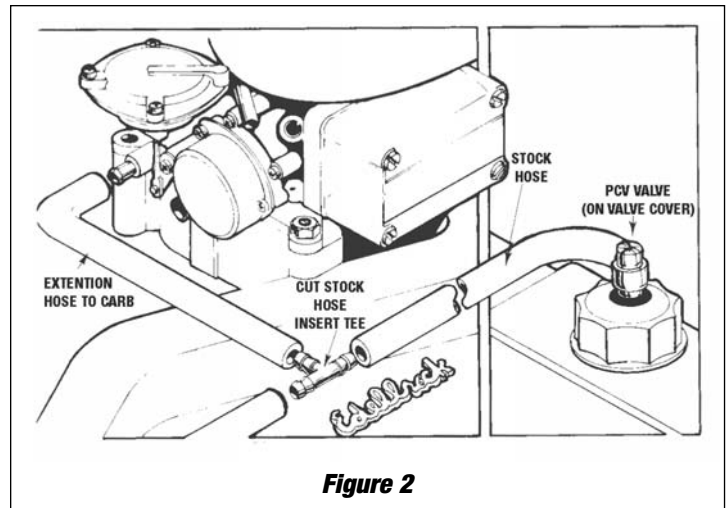
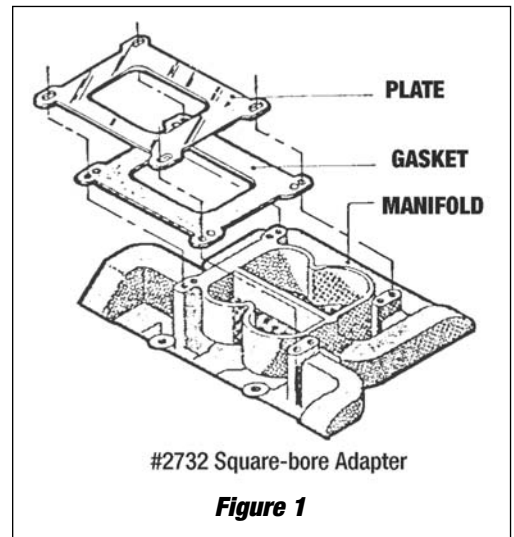

**INSTALLATION PROCEDURE**

1. Use only recommended intake gaskets set when installing this intake manifold.
2. Fully clean the cylinder head intake flanges and the engine block end seal surfaces.
3. Apply Edelbrock Gasgacinch sealant P/N 9300 to both cylinder head flanges and to the cylinder head side of the gaskets, allow to air dry, and attach the intake gaskets.
4. Do not use cork or rubber end seals. Use RTV silicone sealer instead. Apply a 1/4" high bead across each block end seal surface, overlapping the intake gasket at the four corners. This method will eliminate end seal slippage.
5. Install the intake manifold and hold-down bolts. Torque all of the manifold bolts in two steps by the sequence shown in Figure 3 to 25 ft/lbs. For ease of installation, we recommend Intake Manifold Bolt Kit #8574.

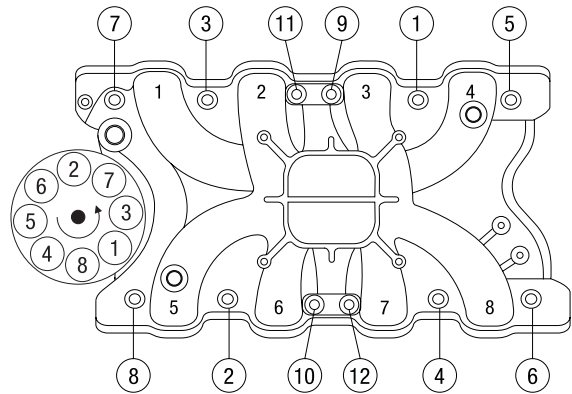

**Figure 3 - 351-M/400 Ford Torque Sequence**  
**Torque Bolts to 25 ft/lbs.**  
**Firing Order: 1-3-7-2-6-5-4-8**  
**Turn Distributor Clockwise to Advance Ignition Timing**

**Edelbrock Corporation • 2700 California St. • Torrance, CA 90503**  
**Tech Line: 800-416-8628 • E-Mail: Edelbrock@Edelbrock.com**