



Victor 5.0 MANIFOLD #2945
MODEL: Ford 5.0 Litre V8 (passenger cars only),
1986 to 1995
INSTRUCTIONS

- **PLEASE** study these instructions, and the General Instructions, carefully before installing your new manifold. If you have any questions or problems, do not hesitate to call our **Technical Hotline at: 1-800-416-8628**.
- **EGR SYSTEM:** This manifold is intended for non-emission, non-EGR racing applications. Because the EGR plate is not used, the throttle body is re-located. A new throttle cable bracket is included with this kit.
- **MANIFOLD:** (RPM range 4000-7500) Designed for 5.0L-based competition EFI engines, the Victor 5.0 EFI aluminum intake manifold is for non-emission, racing applications. Intended for engines modified to produce 400 to 540+ horsepower, this manifold features an all-new design with shorter, larger runners for power to 7500+ rpm. Runners are 11.5" long and 50% larger than Performer 5.0 #3821 runners. The base features an air-gap design to isolate the manifold from hot oil in the valley, and will accept stock or stock replacement fuel rails. The upper manifold will clear tall valve covers and large fuel pressure regulators. The upper and plenum cover are powder-coated light titanium gray. The base is as-cast and not powder-coated. Designed to work with Edelbrock Victor Jr. #7716 and Victor #7721 cylinder heads. Edelbrock/BBK 75mm throttle body is recommended for most applications. Larger injectors may be needed depending upon horsepower levels. Will not fit under stock hood of 1994-95 Mustangs.
NOTE: Air valve location is 0.15" lower and 0.08" forward and 1.25" inward from stock.
- **ACCESSORIES & INSTALLATION ITEMS:** Major recommendations are listed below. However, due to the variety of years, makes and models to be covered, please review each part listed in the Installation Items section of the Edelbrock catalog to decide whether more items are required for your specific vehicle than are mentioned in these instructions.
- **POWER PACKAGE:** Edelbrock Victor 5.0 manifolds are compatible with Edelbrock Victor Jr. heads #7116 or Victor heads #7721. The port exit is sized for use with Fel-Pro #1262 intake gaskets.
- **THROTTLE BODY RECOMMENDATIONS:** Edelbrock/BBK 75mm throttle body #3826 recommended for most applications. Some applications may benefit from the use of 80mm throttle bodies.
- **HOOD CLEARANCE:** The Victor 5.0 #2945 has been optimized for competition level applications and will not fit under stock '94-95 Mustang hoods without modification (all years should check clearance). The simplest level of modification is to trim away the underhood blanket near the interference point at the front of the plenum. If more clearance is required, the upper plenum flange may be machined 0.200" where it bolts to the lower manifold. Trim the long manifold bolts accordingly. Aftermarket raised hoods are the best solution to the problem.

• **REMOVAL**

1. Disconnect battery negative cable and drain cooling system.
2. Disconnect necessary electrical connections, control cables, linkages, vacuum hoses, ventilation hoses, and coolant hoses at throttle body and manifold. **Do not disconnect fuel lines unless absolutely necessary. Special tools and procedures are required to re-install fuel lines.** See "Fuel Line Removal and Installation".
3. Remove distributor cap and spark plug wires as an assembly. Place reference mark on distributor for rotor alignment during reassembly. Remove retaining bolt and distributor.
4. Remove cover plates, retaining bolts, upper intake manifold and gasket.
5. Remove accessory brackets attached to lower manifold. Remove heater tube assembly from lower manifold. The stock heater tube assembly will interfere with the Victor 5.0 throttle bracket and cable arrangement. If a heater is required in your application, re-route your heater hoses. Remove retaining bolts, lower manifold, gaskets, and seals.

• **INSTALLATION**

- CAUTION:** Do not use non-embossed high performance or competition type intake gaskets for street application. Due to material deterioration under long-term driving conditions, internal leakage of both vacuum and oil may occur. Use only Fel-Pro printoseal #1262 or OE equivalent when installing Edelbrock manifolds for street applications. For best results port match manifold base to cylinder heads used.
1. Clean all gasket surfaces. Apply a 1/4" bead of RTV silicone sealer at junction of cylinder head and cylinder block surface **BEFORE** gaskets are installed.
 2. Apply Edelbrock Gasegacinch sealant, #9300, to both sides of the manifold as well as head surfaces. This procedure ensures a good seal.
 3. Install intake manifold gaskets on heads.
 4. Eliminate the end seals. Use RTV silicone sealer instead. Apply a bead of sealant approximately 1/4" high across the front and rear block end seal surfaces, overlapping the intake gasket at the four corners. This method eliminates end seal slippage and deterioration.

5. For ease of installation, we recommend using Edelbrock Manifold Bolt & Washer Kit, #8524.
6. Install lower intake manifold and retaining bolts. Attach throttle bracket (supplied) to manifold using basehole bolts #3 & #7 in figure 1. The throttle bracket may require some trimming to clear certain racing valve covers. Tighten bolts to 15-18 ft./lbs. in sequence. See Figure 1.
7. If fuel rail and injectors were disconnected, install components with new O-rings on fuel lines. Use only specified fuel resistant brown O-rings. Lightly coat O-rings with clean engine oil before installing. Clean fittings and replace garter spring if necessary.
8. Install upper manifold and gasket (dry) using hardware supplied (see Figure 1 and Fastener Location chart). Upper manifold must be positioned so that the throttle body is on the passenger side of vehicle, not driver side. Don't overtighten manifold base-to-manifold upper fasteners. Use a short box or open end wrench only. Install plenum cover and gasket (dry) with allen head screws provided.
9. To smooth the crossover, we have eliminated the stock vacuum tree. Use the 3/8" NPT 90° elbow and 3/8" NPT to hose fitting in the rear of the upper manifold. Also fit the 1/8" NPT to 3/16" hose fitting in the rear 1/8" NPT boss. Use the vacuum line supplied and "tee" to feed the fuel pressure regulator and the MAP sensor from this source.
10. **NOTE:** When installing throttle cable, the #4 injector will need to be rotated to move its electrical connector out of the way. To re-install remaining components, reverse removal procedure. Adjust all control cables. If automatic transmission equipped using Edelbrock throttle body, refer to throttle body instructions for transmission T.V. (throttle valve) cable linkage adjustment. Fill cooling system with coolant. Connect battery negative cable.
11. A retorque of the manifold bolts is recommended after several operation cycles (start-up, bring to operating temperature, cool-down). Retorque when engine is cold.

- **FUEL LINE REMOVAL AND INSTALLATION**
(Optional; Do Not remove fuel lines unless necessary)
CAUTION: Fuel system is under pressure. Pressure must be released before servicing fuel system components.
1. Remove fuel cap to release fuel tank pressure. Using EFI pressure gauge (T80L-9974-B), release fuel pressure from fuel pressure relief on fuel rail.
 2. Before disconnecting fuel lines, disconnect negative battery cable. To disconnect fuel lines, remove retaining clip from outside of fuel line coupling.
 3. Use Spring Lock Coupling Remover (D87L-9280-A) for 3/8" line or (9D87L-9280-B) for 1/2" line. Install spring lock coupling remover on fuel line coupling so it enters cage opening. See Figure 3.
 4. Push spring lock coupling remover into cage opening to release female fitting from garter spring. Pull couplings apart. Remove spring lock coupling remover.
 5. To install fuel lines, install new O-rings on fuel lines. Use only specified fuel resistant brown O-rings. Before installing, lightly coat O-rings with clean engine oil. Clean fittings and replace garter spring (if necessary).
 6. Fit female fitting to male fitting and push until garter spring snaps over flared end of female fitting. Ensure lines are locked together and garter spring is over female fitting flared end.
 7. Install retaining clip. Ensure horseshoe portion of clip is over coupling. **DO NOT** install retaining clip over rubber fuel line. **NOTE:** Black retaining clip should be installed on fuel supply line and Gray clip on fuel return line.

- **GASKETS**

1. Replacement plenum cover and manifold top to manifold bottom gaskets available as Edelbrock #7232.
 2. Recommended intake gasket: Fel-Pro #1262.
- **MANIFOLD TORQUE**—Torque all manifold bolts circled in Figure 1 to 15-18 ft/lbs. See Figure 1 for proper sequence.

- **FIRING ORDER AND CYLINDER NUMBERING**—For firing order and cylinder numbering, see Figure 2.

- **CYLINDER HEADS**

Manifold must be used with modified or high performance cylinder heads to achieve full power potential. Edelbrock Victor Jr. Ford cylinder heads #7716 are fully assembled, ready to run cylinder heads that are designed to work with this intake manifold.

- **CAMSHAFT, HEADERS AND ELECTRONICS**

The Victor 5.0 manifold is designed for use with racing camshafts and full length headers. Your ECM must be capable of controlling the engine to 7500 rpm. For best results, it should be programmable. Your fuel injectors must flow enough fuel for your power level; use the following formula:

Minimum Injector Size (lbs/hr) = (intended horsepower) ÷ 16
Use 20% over minimum for best results.

Fuel Pump Size (gals/hr) = (injector size) x 1.33

Fuel Pump Size (liters/hr) = (injector size) x 5.32

• **KIT CONTENTS – #2945**

- 1– 1/8" pipe to 3/8" hose fitting
- 1– 1/8" pipe to 3/16" hose fitting
- 1– 3/8" pipe to 3/8" hose fitting
- 1– 3/8" pipe 90° fitting
- 1– 3/16" vacuum tee fitting
- 2– 1/8" pipe plugs
- 2– 3/8" pipe plugs
- 4– 5/16"-18 x 1-1/4" flange head bolts
- 2– 5/16"-18 x 5" flange head bolts
- 2– 5/16"-18 x 5-1/4" hex head bolt
- 8– 1/4"-20 x 1" allen head bolts
- 1– 10" length 5/32" vacuum line
- 1– base-to-upper gasket, included in Edelbrock #7232
- 1– plenum cover gasket, included in Edelbrock #2947
- 1– Throttle bracket

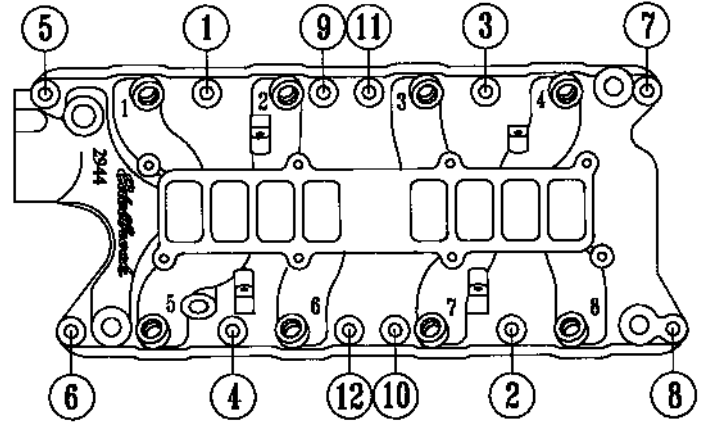
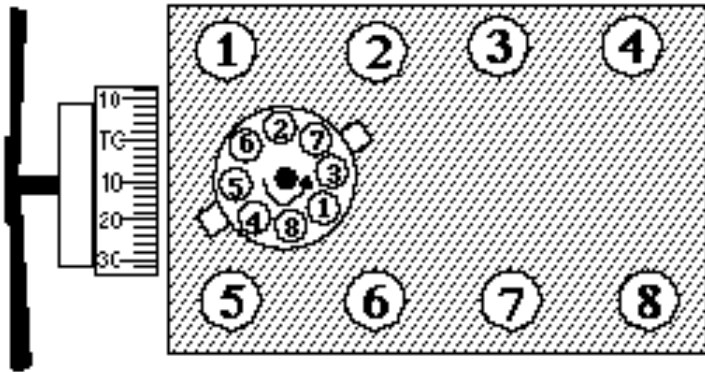
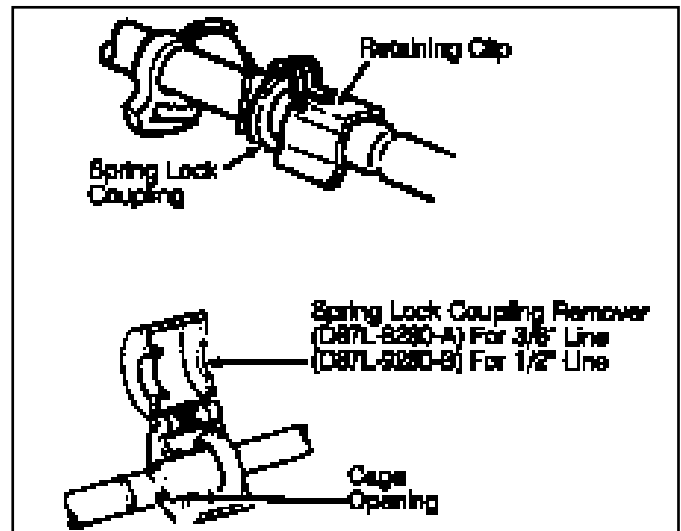

Figure 1—Intake Manifold Tightening Sequence and manifold top-to-bottom fastener locations



*Figure 2—5.0 Litre Ford
Firing Order 1-3-7-2-6-5-4-8
Turn Distributor Clockwise to Advance Timing*



*Figure 3
Disconnecting Fuel Lines*

- **PLEASE** complete and mail your warranty card. Be sure to write the model number of this product in the "Part # ____" space.
- **THANK YOU**