

INSTALLATION INSTRUCTIONS

IMPORTANT NOTES:

- Any time you are working under a vehicle, be sure to use the proper jack stands and tire chocks to prevent any shifting or slipping of the car. Never use a jack only to support the vehicle while changing shocks.
- Inspect shock brackets or mounting points before installation to make sure they are not broken or bent.
- **Do not attempt to disassemble these shocks.** Return damaged shocks to Edelbrock for any necessary service or repairs.
- **PLEASE READ THESE INSTRUCTIONS ENTIRELY BEFORE BEGINNING**
- Proper installation is a must to realize the maximum performance improvements. Follow these steps carefully.

USE THE RIGHT SHOCK FOR YOUR VEHICLE

- Use Performer IAS shocks only for the applications for which they are listed. Each shock is specifically tuned for that vehicle's weight, suspension geometry, and other characteristics.
- Compare original shock mounting style and hardware with your new shocks before starting installation. If original hardware is not reusable, it should be replaced with OEM quality and style hardware.
- Shocks are tuned to vehicle manufacturer's recommendation for tire pressure, not necessarily the max inflation pressure listed on sidewall of tire.
- Raised or lowered vehicles which use original specification shocks may use the Performer IAS shock for that application.

IMPORTANT INSTALLATION NOTES

- If you are uncertain of proper shock installation procedure, please **consult appropriate service manual**. Torque all fasteners to vehicle manufacturer's specs. **NOTE:** On Post Mount shocks, finger tighten nut to achieve zero clearance between the retaining washers and the bushings, then continue to tighten approximately 5-6 turns to achieve proper pre-load. Bushings should be slightly bulged. Secure with Jam Nut. On some vehicles, nut may bottom out on stud before 5-6 turns, which is proper for those applications.
- Unlike other shocks, **Performer IAS shocks must be mounted with the shock body up and the piston rod down.** This is necessary because the inertia valve, which senses wheel movement, is mounted to the piston rod. **Note:** Piston rod is covered by black rubber boot.
- OEM mounting hardware may be either standard or metric. **Make sure you have the proper tools before starting.** Do not interchange hardware. **Use new mounting hardware provided with your shocks,** and re-use original mounting hardware in all other locations.
- Performer IAS shocks have a high pressure nitrogen gas charge and come with a restraining strap which holds the shock in a compressed position. To ease most installations, **leave the strap on until you have secured one end of the shock,** then cut the strap and quickly guide the other end of the shock into position as it expands. Strap must be cut before some installations, such as when strap goes around post.
- Wire ties are provided to secure the shock boot to the shock body. On some installations (especially where the shock must pass through a hole in the lower control arm) **it is necessary to put the wire tie on after the shock is installed.**

INSTALLATION NOTES CONTINUED ON BACK

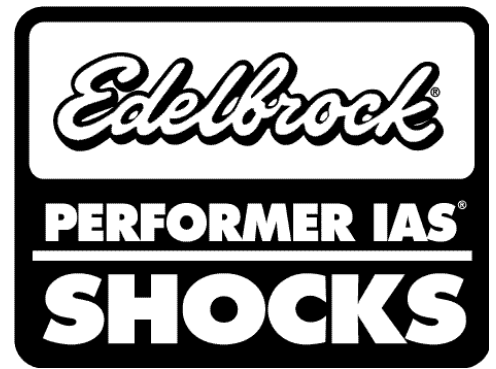
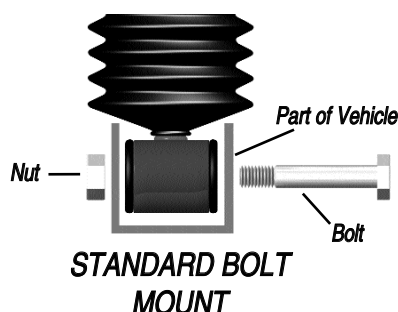
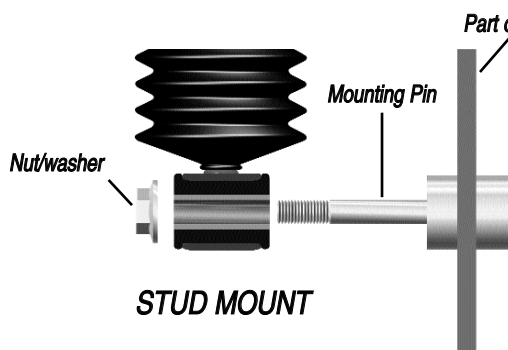

SHOCK POST MOUNT

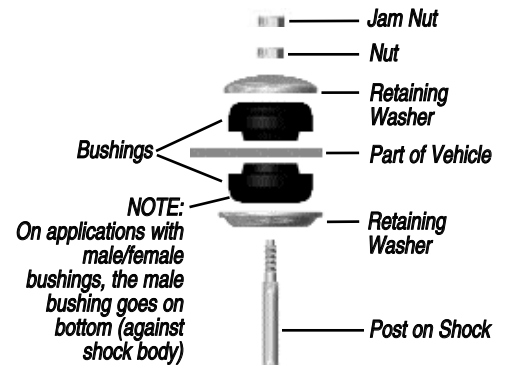

BODY OF SHOCK MUST MOUNT UP!

SHOCK BOOT MUST MOUNT DOWN!

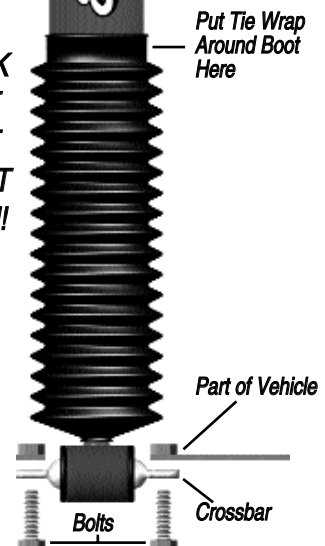

- After installing shocks and before driving vehicle, **check for clearance of exhaust, brake or gas lines, electrical wiring, etc.**
- After installation, **drive the vehicle cautiously for the first few miles** to develop a feel for the improved handling and ride quality. After 10 miles, inspect installation, re-check torque on all fasteners, and verify adequate component clearance. Allow a 20-25 mile break-in period for best performance from your new shocks.

EDELBROCK TECHNICAL HOTLINE

- Consult our **Technical Hotline at 1-800-416-8628** from 8am-12:30 & 1:30-5pm PST, weekdays, for new applications or other installation questions.

SPECIAL NOTES FOR FORD VEHICLES

1. On some Ford models it will be necessary to remove the original 1-piece rubber bushing (front upper stud mount) by cutting. It will be replaced by our 2-piece urethane bushings.
2. Some 1995-97 Explorers come equipped with a third shock absorber

mounted on the rear axle. This shock should be retained after installation of Edelbrock Performer IAS shocks on vehicles with stock ride height. On lowered Explorers using shocks #3389/3489 only, remove the third shock from the rear axle.

PERFORMER IAS® SHOCK ABSORBER LIMITED LIFETIME WARRANTY

Edelbrock Corporation guarantees for a limited lifetime each new Performer IAS Shock Absorber to be free from factory defects (except for finish and shock boot) from date of purchase, provided that the product is properly installed, subjected to normal use and service and that the product is not modified or changed in any way, nor subjected to negligence, or used for racing or competition purposes. Should a part become defective, it should be returned to the original selling dealer or shipped freight prepaid to Edelbrock Corporation. It must be accompanied with the sales receipt and a clear description of the problem.

- Edelbrock Corporation reserves the right to replace or repair the defective part and return said part freight prepaid. This warranty covers the replacement or repair of the product only and does not cover the cost of removal and installation.
- Damage or defects resulting from collision, improper installation, off-road use or road hazards, are not covered by this warranty. The warranty for Performer IAS Shock Absorbers extends only to the original purchaser only for the lifetime of the original vehicle in which it is installed.

PERFORMER IAS® SHOCK ABSORBER 30 DAY MONEY BACK GUARANTEE

Edelbrock Corporation guarantees that its patented Performer IAS Shock Absorbers® will give customer satisfaction regarding shock absorber performance. If you are not completely satisfied with the performance of the Performer IAS Shock Absorbers, you may return the shock absorbers (accompanied by the original sales receipt) to the place of purchase within thirty (30) days of purchase for a full

refund. Sorry, but this guarantee extends only to shock absorbers purchased as a complete set of four and which have been correctly installed and subjected to normal use and service and have not been modified or altered in any respect, abused or used for racing or competition purposes.

Edelbrock Corporation shall not be liable for any and all consequential damages occasioned by the breach of any written or implied warranty pertaining to this sale in excess of the purchase price of the product sold.

If you have any questions regarding a product or installation, please contact our Technical Department at 1-800-416-8628 between 8:00 am to 12:30 pm; 1:30 to 5:00 pm, Pacific time, Monday to Friday.

