



PERFORMER TRUCK 5.0 INTAKE MANIFOLD
For 1987-1996 Ford 5.0L V8 with EGR (Trucks ONLY)
Catalog #3841

INSTALLATION INSTRUCTIONS

PLEASE study these instructions carefully before beginning this installation. Most installations can be accomplished with common tools and procedures. However, you should be familiar with and comfortable working on your vehicle. If you do not feel comfortable performing this installation, it is recommended to have the installation completed by a qualified mechanic. If you have any questions, please call our **Technical Hotline at: 1-800-416-8628**, 7:00 am - 5:00 pm, Pacific Standard Time, Monday through Friday or e-mail us at Edelbrock@Edelbrock.com.

IMPORTANT NOTE: Proper installation is the responsibility of the installer. Improper installation will void your warranty and may result in poor performance and engine or vehicle damage.

DESCRIPTION: The Performer Truck 5.0 intake manifold is designed for 1987-1996 5.0L equipped Ford trucks. It is ideally suited to street/strip/off-road applications with an RPM range of idle-5500 RPM. The design provides maximum torque gains in the mid-range where trucks need it most. The manifold features a removable plenum cover allowing access to runners for modification if desired (not necessary for operation below 6000 rpm), and CNC port matched upper and lower manifolds for maximum flow efficiency.

KIT CONTENTS:

- | | |
|---|---|
| <input type="checkbox"/> 1 Base-manifold | <input type="checkbox"/> 8 1/4"-20 x 3/4" Allen head bolts |
| <input type="checkbox"/> 1 Upper manifold | <input type="checkbox"/> 8 5/16"-18 x 1-1/4" hex head bolt |
| <input type="checkbox"/> 1 Plenum cover | <input type="checkbox"/> 8 5/16" split lockwashers |
| <input type="checkbox"/> 1 Base-to-upper gasket | <input type="checkbox"/> 1 1/8 pipe to 3/8" hose fitting |
| <input type="checkbox"/> 1 Plenum cover gasket | <input type="checkbox"/> 1 Low-profile 90° 3/8 hose fitting |
| <input type="checkbox"/> 1 EGR Gasket | <input type="checkbox"/> 2 3/8 pipe plugs |

Emissions Systems: This manifold is intended as a direct replacement for the factory intake manifold. All emissions related factory components are to be retained and functional. The manifold is, therefore, legal for street use in all 50 states, and no C.A.R.B. E.O. number is required. Check local laws for requirements.

ACCESSORIES & INSTALLATION ITEMS: Major recommendations are listed below. See our catalog for details. **To order a catalog, call (800) FUN-TEAM**, or visit www.edelbrock.com.

THROTTLE BODY RECOMMENDATIONS:

APPLICATION	THROTTLE BODY	PARTS REQUIRED FOR INSTALLATION
1987-1995	OEM (Twin Blade)	New OEM Gasket

NOTES: Oversized, replacement twin-blade throttle bodies may also be used. Port-matching may be required.

GASKETS: Do not use competition style intake gaskets for this street manifold. Due to material deterioration over time, internal leakage of vacuum, oil, and coolant may occur. Replacement plenum cover and manifold top to manifold bottom gaskets available as Edelbrock #3833. OEM Ford gaskets will not fit.

INTAKE MANIFOLD	REFERENCE	RECOMMENDED GASKET
3841	(None)	Edelbrock #7220 Port: 1.20" x 2.00", .060" Thickness

NOTE: To ensure maximum performance and a proper seal, Edelbrock gaskets which are specifically designed and manufactured for use with Edelbrock parts must be used.

CAMSHAFT AND HEADERS: Performer Series manifolds are compatible with aftermarket camshafts and headers designed to work in the idle-5500 RPM range. Edelbrock has developed a dyno-matched, street-proven camshaft, Performer-Plus #3722 (For Mass-Air engines only), Shorty Headers #66482/66483, and Cat-Back exhaust system #5680 or #5682. Consult your dealer, Edelbrock catalog, or Edelbrock Technical Hotline for applications.

CYLINDER HEADS: Manifold should be used with modified or high performance cylinder heads to achieve full power potential. Edelbrock Performer 5.0L cylinder heads are fully assembled, ready to run cylinder heads that are designed to work with this intake manifold.

PREP AND TUNING FOR POWER:

NOTE: Local emission laws must be checked for legality of any tuning or ignition changes.

1. Aftermarket ignition programming may be used with Performer series manifolds.
2. Use modified or high performance cylinder heads such as our Performer 5.0.
3. Installation of non-recommended aftermarket headers, camshafts or both with an Edelbrock Performer series manifold may require additional tuning.

INSTALLATION PROCEDURE

Before Beginning: This installation can be accomplished using common tools and procedures. However, you should have a basic knowledge of automotive repair and modification and be familiar with and comfortable working on your vehicle. If you do not feel comfortable working on your vehicle, it is recommended to have the installation completed by a qualified mechanic. Keeping a service manual for your specific vehicle on hand for reference is helpful.

REMEMBER: WHEN WORKING AROUND GASOLINE, DO NOT SMOKE, and KEEP ALL OPEN FLAMES, SPARKS AND OTHER SOURCES OF IGNITION AWAY FROM THE WORK AREA. Failure to do so can result in a FIRE or EXPLOSION.

REMOVAL:

1. Disconnect battery negative cable and drain cooling system.
2. Disconnect necessary electrical connections, control cables, linkages, vacuum hoses, ventilation hoses, and coolant hoses at throttle body and manifold. **Do not disconnect fuel lines unless absolutely necessary. Special tools and procedures are required to re-install fuel lines. See "FUEL LINE REMOVAL AND INSTALLATION".**
3. Remove distributor cap and spark plug wires as an assembly. Place reference mark on distributor for rotor alignment during re-assembly. Remove retaining bolt and distributor.
4. Disconnect throttle linkage and air inlet tubes. Unbolt EGR valve from manifold and swing away (loosen pipe fitting on exhaust manifold if necessary).
5. Remove retaining bolts, upper intake manifold and gasket.
6. Remove accessory brackets attached to lower manifold. Remove heater tube assembly from lower manifold. Remove retaining bolts, lower manifold, gaskets, and seals.
7. Mark vacuum line locations. Vacuum lines will relocate to the stock positions on the #3841, with the exception of the MAP sensor. Its fitting will relocate from the top of the plenum to the bottom of the plenum.
8. To facilitate easy assembly, tag all electrical connectors prior to disassembly.

INSTALLATION

1. Clean all gasket surfaces. Apply Edelbrock Gasgacinch sealant, #9300 to the cylinder head side of the gasket as well as head surfaces. Allow to air-dry.
2. Apply a 1/8" bead of O2 sensor safe RTV silicone sealer at the junction of the cylinder head and engine block surface BEFORE gaskets are installed. Install intake manifold gaskets on head.
3. Eliminate the end seals. Use RTV silicone sealer instead (O2 Sensor Safe). Apply a bead of sealant approximately 1/4" high across the front and rear block end seal surfaces, overlapping the intake gasket at the four corners. This method eliminates end seal slippage and deterioration.
4. For ease of installation, we recommend using Edelbrock manifold bolt and washer kit #8524. It may be necessary to re-use the original stud bolt to hold heater tube bracket in hole #3 **(See Figure 1)**.
5. Install lower intake manifold and retaining bolts. Tighten bolts to 15-18 ft./lbs. in sequence **(See Figure 1)**.
6. If fuel rail and injectors were disconnected, install components with new O-rings on fuel lines. Use only specified fuel resistant brown O-rings. Lightly coat O-rings with clean O-ring lube (brake lube) before installing. Clean fittings and replace garter spring, if necessary.
7. Install the supplied 90° fitting in the rear of the upper manifold prior to installing onto the manifold base. Use thread sealer on the threads and orient the fitting at the 4:00 o'clock position (as viewed from the rear).

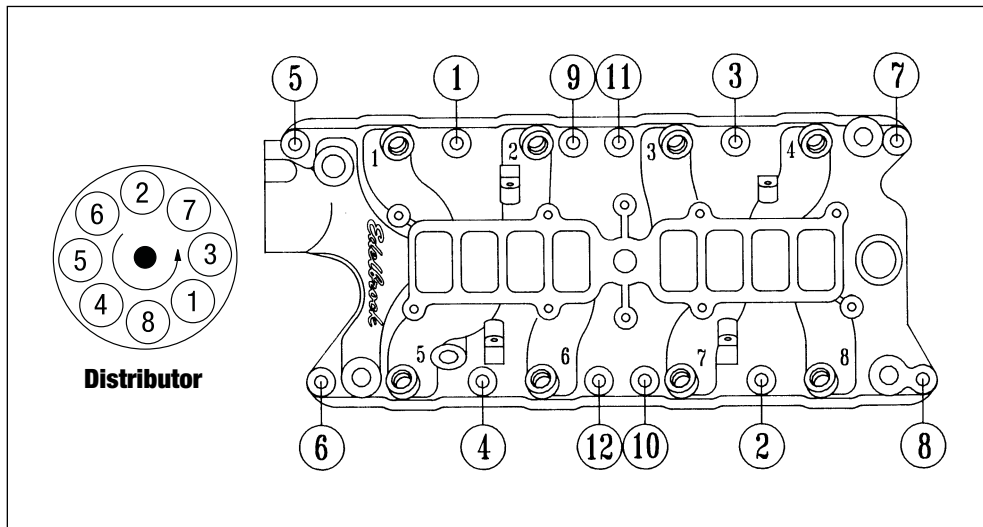

Figure 1 - Intake Manifold Tightening Sequence and Firing Order

Torque Bolts to 15-18 Ft./Lbs.

5.0L Ford Firing Order 1-3-7-2-6-5-4-8

Turn Distributor Clockwise to Advance Timing

8. Install upper manifold and gasket (dry) using the hardware supplied. Upper manifold must be positioned so that the throttle body is towards the front of the vehicle. Do not overtighten manifold base-to-manifold upper fasteners. Use a short box or open end wrench only.
8. Install the plenum cover and gasket (dry) with the supplied Allen head bolts.
9. Remove original throttle valve/EGR plate studs from stock manifold and install in new manifold. To re-install remaining components, reverse removal procedure. Adjust all control cables. If automatic transmission equipped using an aftermarket throttle body, refer to throttle body instructions for transmission T.V. (throttle valve) cable linkage adjustment. Fill cooling system with coolant. Connect battery negative cable.
11. A re-torque of the manifold bolts is recommended after several operation cycles (start-up, bring to operating temperature, cool-down). Re-torque when engine is cold.
4. Push spring lock coupling remover into cage opening to release female fitting from garter spring. Pull couplings apart. Remove spring lock coupling remover.
5. To install fuel lines, install new O-rings on fuel lines. Use only specified fuel resistant brown O-rings. Before installing, lightly coat O-rings with clean O-ring lube (brake lube). Clean fittings and replace garter spring, if necessary.
6. Fit female fitting to male fitting and push until garter spring snaps over flared end of female fitting. Ensure lines are locked together and garter spring is over female fitting flared end.
7. Install retaining clip. Ensure horseshoe portion of clip is over coupling. **Do not** install retaining clip over rubber fuel line.

NOTE: **Black** retaining clip should be installed on fuel supply line and **Gray** clip on fuel return line.

FUEL LINE REMOVAL AND INSTALLATION

CAUTION: **Do not** remove fuel lines unless necessary.

CAUTION: Fuel system is under pressure. Pressure must be released before servicing fuel system components.

1. Remove fuel cap to release fuel tank pressure. Using EFI pressure gauge (T80L-9974-B), release fuel pressure from fuel pressure relief on fuel rail.
2. Before disconnecting fuel lines, disconnect negative battery cable. To disconnect fuel lines, remove retaining clip from outside of fuel line coupling.
3. Use Spring Lock Coupling Remover (D87L-9280-A) for 3/8" line or (9D87L-9280-B) for 1/2" line. Install spring lock coupling remover on fuel line so it enters cage opening (See Figure 2).

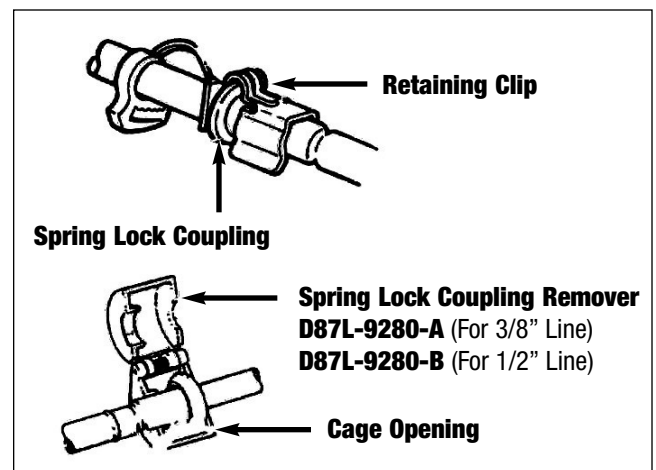

Figure 2 - Disconnecting Fuel Lines



Edelbrock Corporation • 2700 California St. • Torrance, CA 90503
Tech-Line: 1-800-416-8628 • E-Mail: Edelbrock@Edelbrock.com