



INSTALLATION INSTRUCTIONS

PLEASE study these instructions carefully before beginning this installation. Most installations can be accomplished with common tools and procedures. However, you should be familiar with and comfortable working on your vehicle. If you do not feel comfortable performing this installation, it is recommended to have the installation completed by a qualified mechanic. If you have any questions, please call our **Technical Hotline at: 1-800-416-8628**, 7:00 am - 5:00 pm, Pacific Standard Time, Monday through Friday or e-mail us at Edelbrock@Edelbrock.com.

IMPORTANT NOTE: Proper installation is the responsibility of the installer. Improper installation will void your warranty and may result in poor performance and engine or vehicle damage.

DESCRIPTION: Edelbrock Sure-Seat valve springs are made of high quality wire and are wound to close specifications for use with our Performer-Plus camshafts. These quality controlled springs are part of Edelbrock's concept of a dyno-tested parts combination. In most cases Sure Seat valve springs have inner dampeners. Edelbrock springs are carefully inspected for potential flaws and can be depended on for performance and durability.

CAUTION: For successful installation, use only the springs and parts recommended by Edelbrock for each camshaft application. If you have any questions, do not hesitate to call our **Technical Hotline at: 1-800-416-8628**.

NOTE: If an application requires special parts, a parts list will be included with your spring set, listing recommended parts and part numbers.

VALVE SPRING REMOVAL & REPLACEMENT: Due to the many years and models involved, it would be impossible to cover all applications. For ease of installation and correct installation, we suggest you refer to a service manual for your year and model vehicle or Motors, Chilton, or Mitchell service manuals for tools and procedures to follow.

CAUTION: The following instructions must be read and dimensions checked. These dimensions are critical and can cause parts wear and possible breakage if not correct. See page 3 for correct spring part numbers and recommended installed spring height.

VALVE SPRING INSTALLED HEIGHT: Installed height is the dimension between the valve spring retainer and cylinder head valve spring pad (**See Figure 1 Dimension "A"**). In some cases, spring shims may be needed for correct spring setting.

NOTE: Remember Dimension "A" is valve spring length only. Include shims if used. Never shim springs to a lesser dimension than recommended. Shimming to a lesser dimension will cause coil bind or parts damage.

VALVE SEAL INSTALLATION: Improper installation of incorrect or special aftermarket valve guide seals, without sufficient clearance between spring retainer and valve guide seal, can cause camshaft and lifter wear and even parts breakage (**See Figure 1, Dimension "B"**). Check Edelbrock camshaft specifications for maximum valve lift.

NOTE: Dimension "B" should be a minimum of valve lift plus .050".

CAUTION: Failure to install springs and seals correctly may void warranty. Edelbrock Sure Seat valve springs are supplied to cover engines using the same valve spring for both intake and exhaust as one set.

NOTE: Check your vehicle and application sheet for correct spring selection.

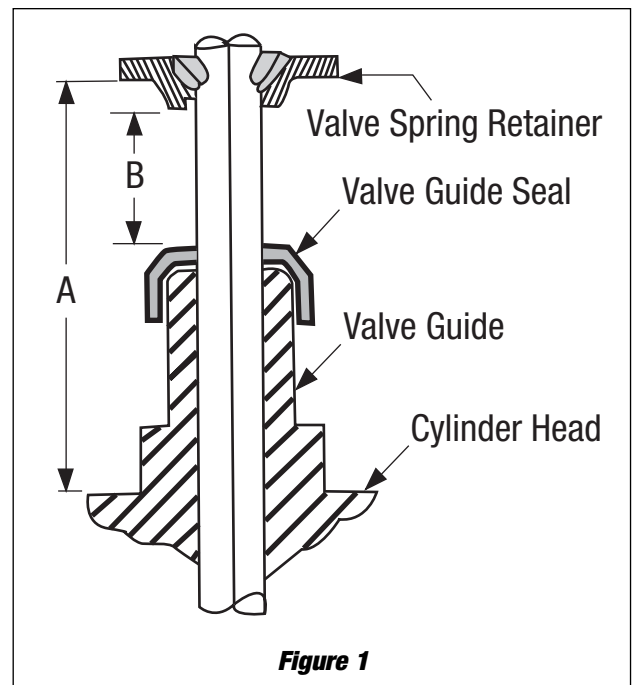

Figure 1

ROTATOR TYPE RETAINERS: The information in this section will help you determine if your cylinder heads are or are not equipped with rotator type valve spring retainers. Rotator type valve spring retainers are generally used with exhaust valves (**See Figure 2**). Commonly, rotator type retainers are thicker than standard or intake type retainers (**See Figure 2**). Rotator type retainers use a shorter exhaust valve spring (in most cases). There are some exceptions. See examples A and B below:

Example A: Some late model GM big-block Chevrolet cylinder heads install the rotator assembly below the exhaust spring, next to the cylinder head surface (**See Figure 3**). This exhaust spring seat surface is machined deeper into the head than the intake spring seat, to accommodate the additional thickness of the rotator assembly. This allows the use of the same length valve spring for both the intake and exhaust valves.

Example B: Some late model GM small-block Chevrolet cylinder heads (lightweight series) also have deeper exhaust valve spring seats to accommodate the additional thickness of the rotator assembly. Again, this allows the use of the same length valve spring for both the intake and exhaust valves.

NOTE: The above information should enable you to select the proper spring set for your application

CAUTION: The improper set of valve springs could cause coil bind and severe engine damage!

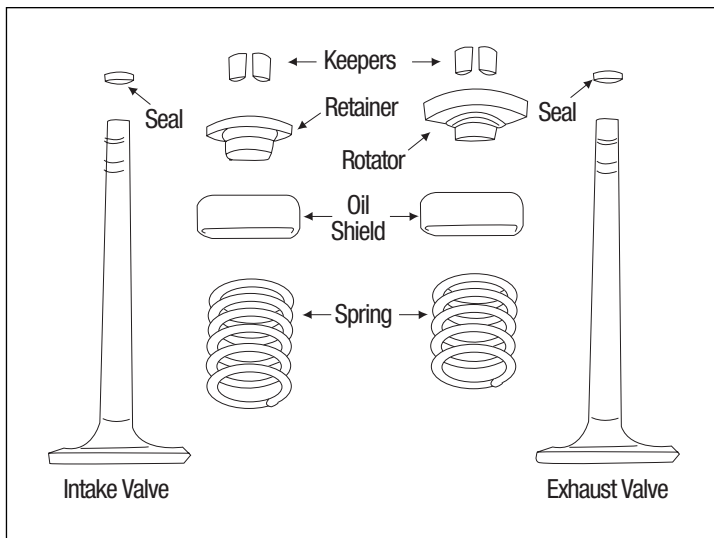

Figure 2
Intake and Exhaust Valve Retainer Assemblies

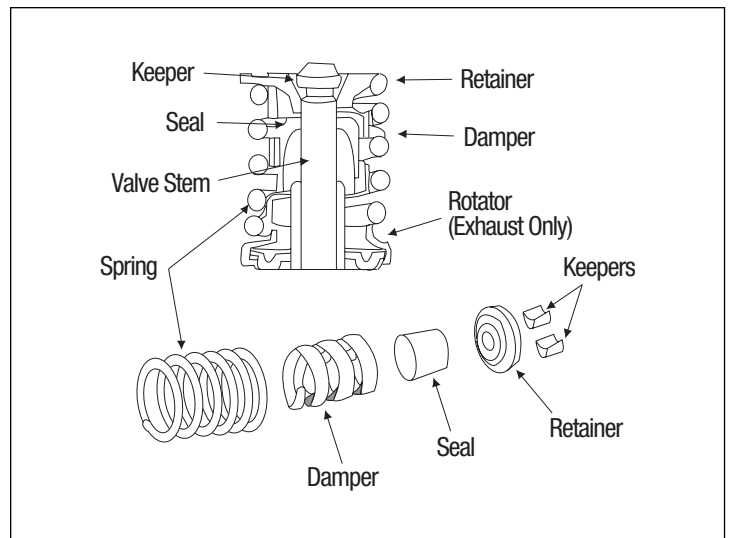

Figure 3
Exhaust Valve Rotator When Used

EDELBROCK #5800 AND 5900 SERIES SURE SEAT VALVE SPRING PART NUMBERS & DIMENSIONS

| Engine | Part Number | Installed Height (Dim. "A") | | Seat Pressure (Lbs.) | Max Valve Lift + .050" (Dim. "B") | |
|--|---------------------|----------------------------------|----------------------------------|----------------------|-----------------------------------|-----------------------|
| | | Intake | Exhaust | | Intake | Exhaust |
| AMC 304/401 V8 | 5832 (Standard Set) | 1.812" | 1.812" | 83-93 | .448" + .050" = .498" | .472" + .050" = .522" |
| AMC 304/401 V8 | 5932 (Rotator Set) | 1.812" | 1.625" | 83-93 | .448" + .050" = .498" | .472" + .050" = .522" |
| Chevrolet 4.3L V6 | 5814 (All) | 1.700" | 1.700" | 104-116 | .479" + .050" = .529" | .488" + .050" = .538" |
| Chevrolet 262-400 V8 | 5802 (Standard Set) | 1.700" | 1.700" | 76-84 | .442" + .050" = .492" | .442" + .050" = .492" |
| Chevrolet 262-400 V8 | 5902 (Rotator Set) | 1.700" | 1.610" | 76-84 | .442" + .050" = .492" | .442" + .050" = .492" |
| Chevrolet 396-454 V8 | 5862 (All) | 1.880" | 1.880" | 84-96 | .500" + .050" = .550" | .500" + .050" = .550" |
| Chrysler 318-360 V8 | 5877 (Standard Set) | 1.650" | 1.650" | 90 | .420" + .050" = .470" | .420" + .050" = .470" |
| Chrysler 318-360 V8 | 5977 (Rotator Set) | 1.650" | 1.500" | 90 | .420" + .050" = .470" | .420" + .050" = .470" |
| Chrysler 383-440 V8 | 5892 (Standard Set) | 1.860" | 1.860" | 120 | .420" + .050" = .470" | .442" + .050" = .492" |
| Chrysler 383-440 V8 | 5992 (Rotator Set) | 1.860" | 1.734" | 120 | .420" + .050" = .470" | .442" + .050" = .492" |
| Ford 289-302 V8 | 5822 (Standard Set) | 1.660" | 1.660" | 90 | .448" + .050" = .498" | .472" + .050" = .522" |
| Ford 289-302 V8 | 5922 (Rotator Set) | 1.660" | 1.600" | 90 | .448" + .050" = .498" | .472" + .050" = .522" |
| Ford 351M-400 V8 | 5872 (Standard Set) | 1.820" | 1.820" | 76-84 | .484" + .050" = .534" | .510" + .050" = .560" |
| Ford 351M-400 V8 | 5972 (Rotator Set) | 1.820" | 1.680" | 76-84 | .484" + .050" = .534" | .510" + .050" = .560" |
| Ford 351-W V8 | 5882 (Standard Set) | 1.780" | 1.780" | 61-69 | .448" + .050" = .498" | .472" + .050" = .522" |
| Ford 351-W V8 | 5982 (Rotator Set) | 1.780" | 1.600" | 61-69 | .448" + .050" = .498" | .472" + .050" = .522" |
| Ford 360-390 V8 | 5806 (Standard Set) | 1.820" | 1.820" | 85-95 | .460" + .050" = .510" | .480" + .050" = .530" |
| Ford 360-390 V8 | 5906 (Rotator Set) | 1.820" | 1.680" | 85-95 | .460" + .050" = .510" | .480" + .050" = .530" |
| Ford 429-460 V8 | 5867 (Standard Set) | 1.820" | 1.820" | 75 | .460" + .050" = .510" | .480" + .050" = .530" |
| Oldsmobile 350R V8 | 5812 (All) | 1.670" | 1.670" | 76-84 | .448" + .050" = .498" | .472" + .050" = .522" |
| Pontiac 350-455 V8 (1965-Later) | 5857 (All) | 1.570" (Inner) 1.590" (Outer) | 1.570" (Inner) 1.590" (Outer) | 100 100 | .420" + .050" = .470" | .442" + .050" = .492" |



Edelbrock Corporation • 2700 California St. • Torrance, CA 90503
Tech-Line: 1-800-416-8628 • E-Mail: Edelbrock@Edelbrock.com