

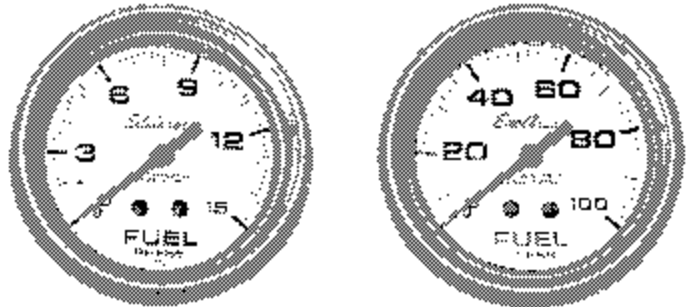

Edelbrock Nitrous Systems 2-5/8" Fuel Pressure Gauge Catalog #73827 & #73829 INSTALLATION INSTRUCTIONS

Please study these instructions carefully before installing your new Fuel Pressure Gauge. If you have any questions or problems, please contact our Technical Hotline at: 1-800-416-8628, 7:00 am to 5:00 pm, Monday through Friday, Pacific Standard Time or e-mail us at edelbrock@edelbrock.com. Please fill out and mail your warranty card.

IMPORTANT: DO NOT mount these gauges in the passenger compartment of the vehicle. These fuel pressure gauges must be mounted outside of the vehicle's interior. Mounting cup kit (Auto Meter #3203 or #3204) is recommended for mounting on the vehicle's cowling in front of the windshield. This is required to prevent the possibility of a dangerous explosion of gas fumes in the vehicle's interior, which could result from a leaky connection between the pressure line and the gauge.



Mechanical Section

1. Determine the best location for mounting the fuel pressure gauge outside of the vehicle's interior. A mounting cup kit (Auto Meter #3203 or #3204) is recommended for mounting on the vehicle's cowling in front of the windshield. Drill the necessary holes and install the rubber grommets provided where the pressure line passes through any sheet metal.
2. Because all fuels are flammable, it is recommended that a premium braided stainless steel pressure line -4AN be used.
3. Route the pressure line through the grommets to the engine compartment. Connect the line to a tee fitting plumbed in line with the fuel line. Be sure to use liquid Teflon sealant on all tapered pipe threads for a good seal. No sealant is required on AN flare fittings. Also make sure that the pressure line is routed away from any sources of heat or moving components.
4. If you choose to use either the green or red light bulb cover, install this over the bulb in the light fixture for the gauge and install the fixture into the gauge by simply pushing the light fixture into the hole on the back of the gauge until the fixture snaps into place.

Note: Test all fittings and hoses for any leakage. If any leaks are detected, determine the cause of the leak and repair. Do not operate the vehicle if any leaks are detected.

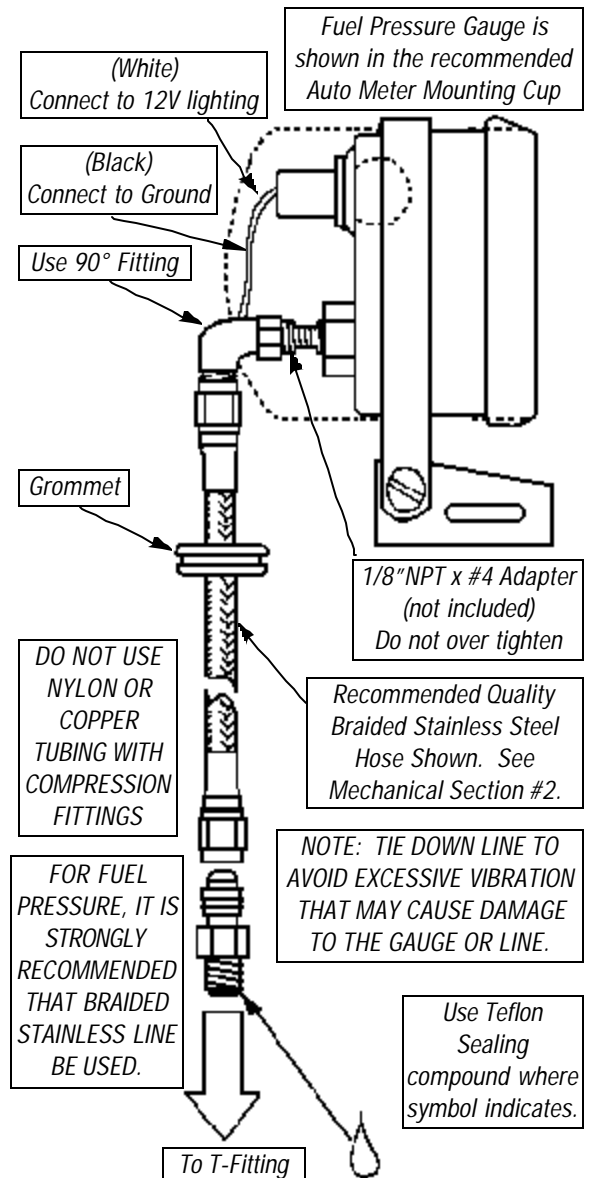

Electrical Section

For maximum electro-luminescent life, do not wire lighting to direct ignition switched 12-volt source. The lighting power source should be routed through OEM dash controls, or a separate rheostat. Power can be achieved by tapping into the factory dash lighting through either the fuse panel or from a 12-volt dash light wire. This will allow you to control the light intensity. Use the appropriate connectors for your particular application. The white wire must be connected to the power source and the black wire to a good ground. Damage to electronic circuits could occur if connected incorrectly.

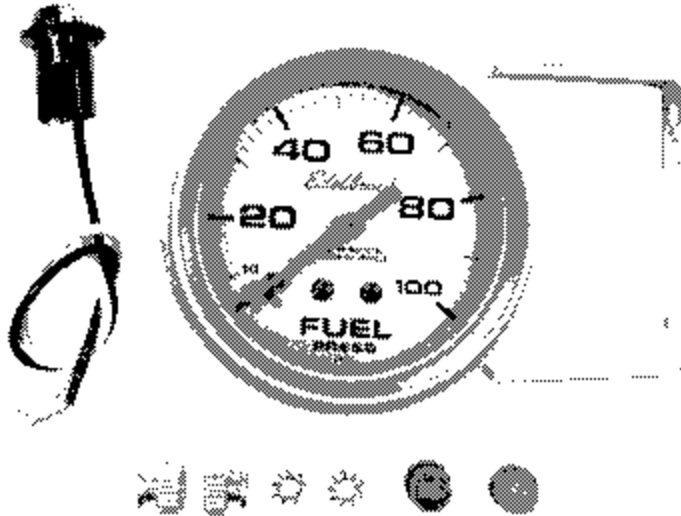

Bill of Materials

<u>Qty.</u>	<u>Description</u>
1	0-15 psi Fuel Pressure Gauge
1	Gauge Light with Harness
2	Star Washers
2	Attaching Screws
1	Gauge Bracket
1	Red Light Cover
1	Green Light Cover

<u>Qty.</u>	<u>Description</u>
1	0-100 psi Fuel Pressure Gauge
1	Gauge Light with Harness
2	Star Washers
2	Attaching Screws
1	Gauge Bracket
1	Red Light Cover
1	Green Light Cover

Edelbrock Corporation
 2700 California Street
 Torrance, CA 90503
 Toll-Free Tech Line: 1-800-416-8628
 Office: 310-781-2222
 Tech E-Mail: edelbrock@edelbrock.com