

# INSTRUCTION SHEET FOR SET #16.1111

Read this instruction sheet thoroughly before initiating any work!

It is recommended that if you are unfamiliar with this type of work that you refer to a qualified service center specializing in this type of work. It is also recommended that if you choose to do this work yourself that a factory service manual be obtained for the proper procedures pertaining to removal, replacement and proper torque specifications for your vehicle. This instruction set is intended as a guideline for the safe installation of Energy Suspension's Polyurethane.

**ENERGY**  
**SUSPENSION** 

1131 VIA CALLEJON, SAN CLEMENTE, CA 92673

## STEP 1

Inspect engine torque mount for excessive wear and cracking. **If** the mount is severely damaged, ENERGY SUSPENSION recommends replacing with a new engine torque mount. Clean any dirt, grease, and excess rubber flashing that may be present inside the engine torque mount.

**NOTE:** IT IS VERY IMPORTANT THAT THE INSIDE OF THE TORQUE MOUNT BE CLEAN AND FREE OF FLASH.

## STEP 2

Install the polyurethane inserts into the torque mount. One insert will be installed on each side of the torque mount. *If supplied in set*, use the nylon retainers. Note: The square head of nylon tie may need to be trimmed to seat flush against insert. Refer to illustration for proper orientation of parts. Reassemble torque mount into engine compartment.

### Parts List:

- 2 - 1172 front position inserts
- 2 - 1173 rear position inserts

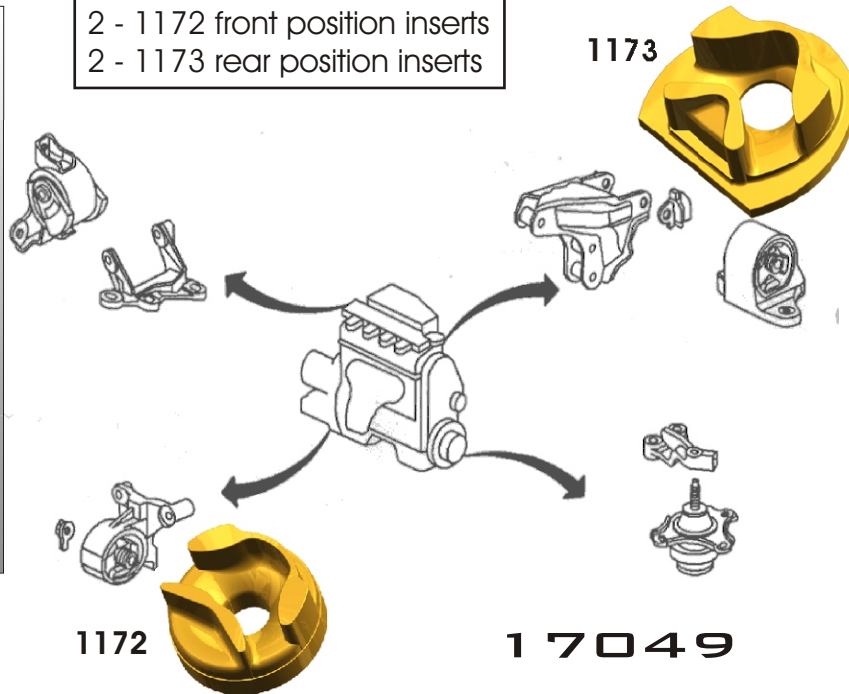

© 2004 Energy Suspension. All rights reserved.  
May not be reproduced, in any form, or by any means,  
without the written consent of Energy Suspension.

# INSTRUCTION SHEET FOR SET #16.1111

Read this instruction sheet thoroughly before initiating any work!

It is recommended that if you are unfamiliar with this type of work that you refer to a qualified service center specializing in this type of work. It is also recommended that if you choose to do this work yourself that a factory service manual be obtained for the proper procedures pertaining to removal, replacement and proper torque specifications for your vehicle. This instruction set is intended as a guideline for the safe installation of Energy Suspension's Polyurethane.

**ENERGY**  
**SUSPENSION** 

1131 VIA CALLEJON, SAN CLEMENTE, CA 92673

## STEP 1

Inspect engine torque mount for excessive wear and cracking. **If** the mount is severely damaged, ENERGY SUSPENSION recommends replacing with a new engine torque mount. Clean any dirt, grease, and excess rubber flashing that may be present inside the engine torque mount.

**NOTE:** IT IS VERY IMPORTANT THAT THE INSIDE OF THE TORQUE MOUNT BE CLEAN AND FREE OF FLASH.

## STEP 2

Install the polyurethane inserts into the torque mount. One insert will be installed on each side of the torque mount. *If supplied in set*, use the nylon retainers. Note: The square head of nylon tie may need to be trimmed to seat flush against insert. Refer to illustration for proper orientation of parts. Reassemble torque mount into engine compartment.

### Parts List:

- 2 - 1172 front position inserts
- 2 - 1173 rear position inserts

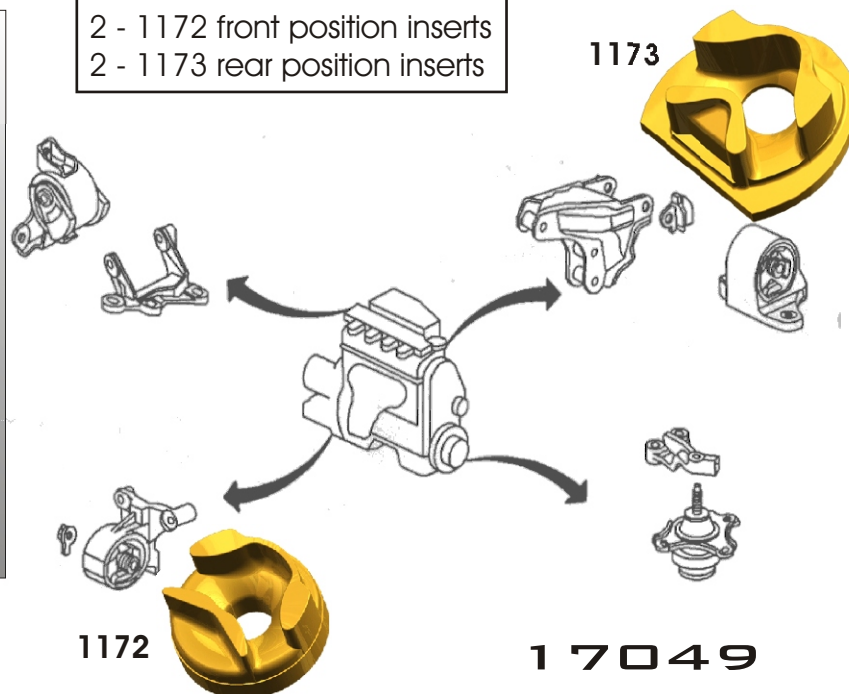

© 2004 Energy Suspension. All rights reserved.  
May not be reproduced, in any form, or by any means,  
without the written consent of Energy Suspension.