

# OPEN FIRST!!

## Instructions for GM style "clamshell" motor mount 3 - mounting holes

**ENERGY SUSPENSION**™

1131 VIA CALLEJON, SAN CLEMENTE, CA 92673

**ENERGY SUSPENSION recommends replacing both left and right side mounts at the same time. Use a new lock nut at the engine bracket cross bolt location.**

Raise vehicle to suitable height and support properly to allow easy access to the engine mounting locations. NOTE: BE SURE VEHICLE IS SECURELY SUPPORTED BEFORE GOING UNDERNEATH. Do not lift engine on crankshaft pulleys or oil pan. If available, use an engine hoist to raise engine. Raise engine to a height needed to remove load from the engine mounts. Remove 5" long engine mounting bolts. Raise the engine again to allow enough clearance between the engine mounting brackets and motor mounts. NOTE: BE CAREFUL NOT TO CAUSE DAMAGE TO OTHER ENGINE COMPONENTS BY RAISING THE ENGINE TOO HIGH, ie, DISTRIBUTOR CAP ON FIREWALL, FAN, etc. Remove bolts securing motor mounts to front crossmember. It may be necessary to remove mounts, one side at a time. Remove motor mounts from the crossmember and inspect the metal shells for damage. NOTE: IT IS EXTREMELY IMPORTANT THAT THE METAL SHELLS BE UNDAMAGED.

**BE SURE TO NOTE THE ORIENTATION OF THE LOCATING TABS ON THE INSERTS IN THE O.E.M. MOUNTS, THE NEW INSERTS SHOULD BE INSTALLED WITH THE TABS THE SAME WAY! REFER TO STEP 2 FOR PROPER ORIENTATION ON VEHICLE.**

### STEP - 1

Use a 3/8" drill bit to drill out rivets/welds. Drill down just enough to remove rivet material to allow the metal shells to be separated. After separation, remove any burrs or sharp edges from the drilled out holes. Be sure the drilled holes have a diameter of at least 5/16".

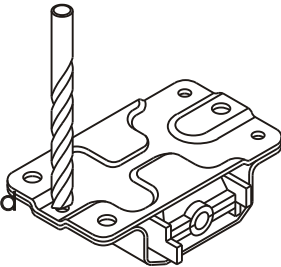

Clean any dirt and grease that may have accumulated inside the metal shells. NOTE: IT IS VERY IMPORTANT THAT THE INSIDE OF THE METAL SHELLS BE CLEAN. At this point, it is your option to have your metal painted, powder coated, or chromed.

### STEP - 2

Be sure to note how your motor mount attaches to the crossmember. The single mounting bolt will be toward the top or toward the bottom, depending on the application. On most applications the locating tabs protruding from the polyurethane insert will be installed as shown in the illustration.

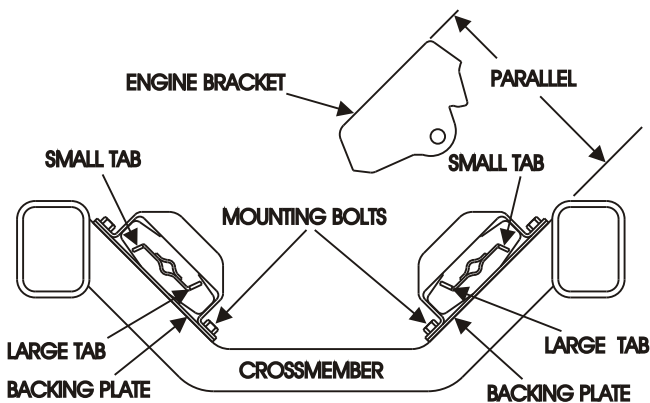

### STEP - 3

Align the bottom backing plate onto the polyurethane insert, making sure the bolt holes line up. Place the assembly in a vise or large clamp, leaving access to the drilled out holes. Use enough clamping force to hold the two metal shells together, without permanently deforming the metal (a slight amount of metal bending may occur, this is normal). To temporarily hold the assembly together, place the tie-wraps provided into the drilled holes, inserting them from the bottom side, leaving the locking end of the tie-wrap on the top side, as shown.

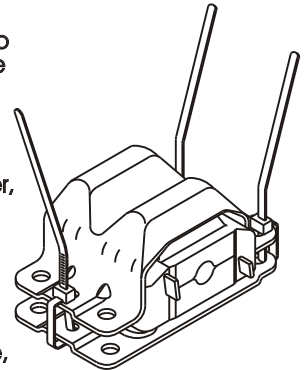

Make sure the tie-wraps are holding firm while releasing the clamp or vise. The metal shells may separate slightly, this is normal. However, excessive separation will prevent mounting bolts from reaching through the crossmember allowing the nuts to start on the bolts. Cut the ends of the tie-wraps off, being sure not to leave any sharp edges.

### STEP - 4

Reassemble motor mounts into engine compartment, leaving all bolts loosened until the 5" long bolts going through the brackets have been successfully installed. Tighten all bolts to factory specifications. If desired, you may remove the remaining portion of the tie-wraps.

NOTE: The ENERGY SUSPENSION Polyurethane motor mount insert will restore your engine to its original height. If adjustments have been made to other engine components, such as, fan shroud, fuel lines, etc. due to sagging, worn motor mounts, these components will need to be readjusted back to their original locations. **Also, be sure to check hood clearance before closing.**

HINT: Due to the many different metal configurations from foreign and domestic manufacturers it may be helpful to apply a thin coat of grease or dish detergent to the polyurethane insert, at metal contact points before installing. This will allow the insert to seat, in turn allowing proper bolt alignment.

17272  
12/3/98 JL

©1998 Energy Suspension. All rights reserved.  
May not be reproduced, in any form, or by any means,  
without the written consent of Energy Suspension.