

# INSTALLATION SHEET

# EXTANGRT TONNO

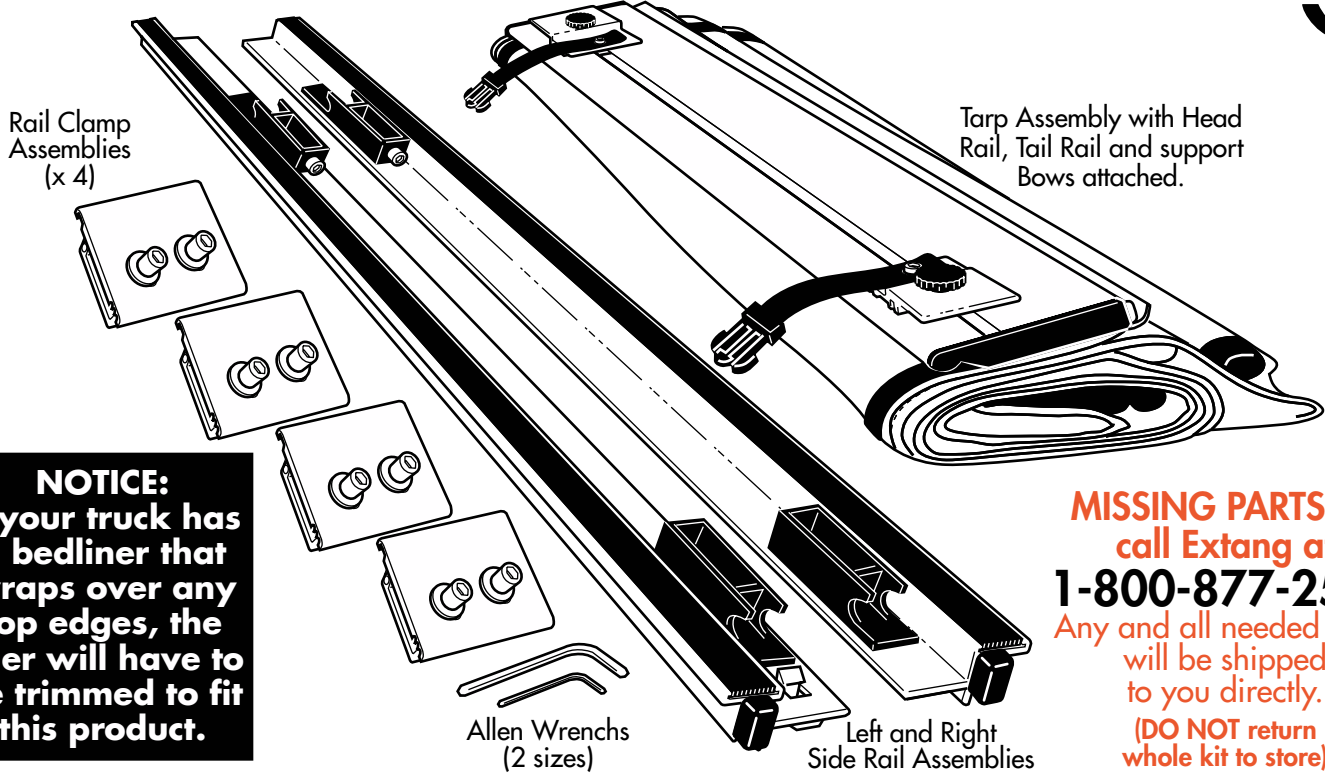

Rail Clamp Assemblies (x 4)

Tarp Assembly with Head Rail, Tail Rail and support Bows attached.

**NOTICE:**  
If your truck has a bedliner that wraps over any top edges, the liner will have to be trimmed to fit this product.

Allen Wrenches (2 sizes)

Left and Right Side Rail Assemblies

**MISSING PARTS???**  
call Extang at  
**1-800-877-2588**  
Any and all needed parts will be shipped to you directly.  
**(DO NOT return whole kit to store)**

**PARTS INCLUDED IN YOUR KIT.** You may want to lay them out in this manner for accessibility.



Wash truck bed.



**Foam has NO adhesive to touch truck finish.**

Remove paper tape from all rails. Discard properly.

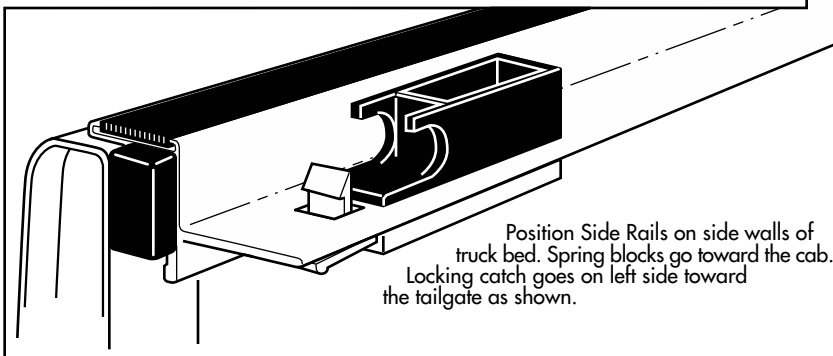
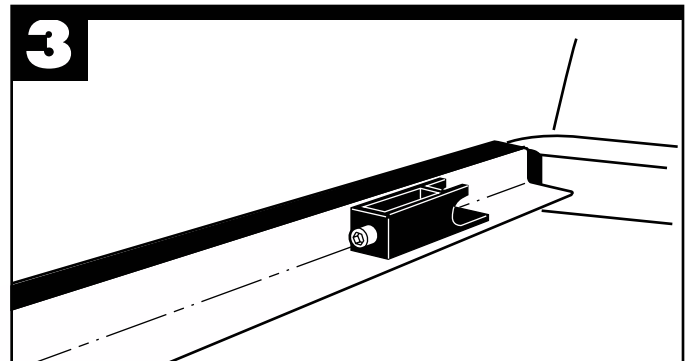

Position Side Rails on side walls of truck bed. Spring blocks go toward the cab. Locking catch goes on left side toward the tailgate as shown.

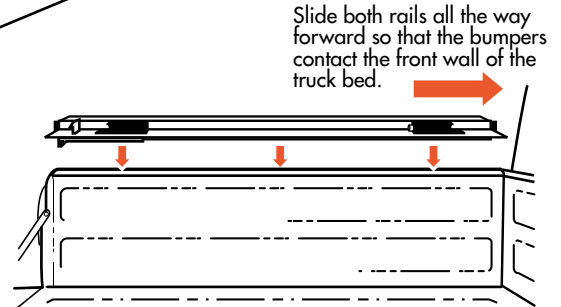

Slide both rails all the way forward so that the bumpers contact the front wall of the truck bed.

**extang**  
Stands for Quality

Extang Corporation  
1901 E. Ellsworth Rd.  
Ann Arbor, MI 48108  
734 677-0444, Fax: 734 677-8409

Visit us at:  
**www.extang.com**

Item No. 0042-0103RH Printed in U.S.A.

**4**

Insert Pre-assembled clamp into the side rail.

Hook slot of flat clamp into lip in side rail.

Raise C-shaped inner clamp to highest position.

**Hand-tighten clamp bolts to hold rail in place.**

8 inches 8 inches

Position rail front-to-rear so that rubber end plugs are evenly against front and tailgate in closed position.

Tighten bolts with large Allen wrench. **(Note: On some vehicles, the down-standing box flange has a sloping surface; with these vehicles it may be necessary to move inner clamp up and down and to shim rail so that rail is flat.)**

**5**

Engage the round edge of the front rail to the spring blocks and rotate the rail down.

Slide the retaining plates out so that they engage the wide flange of the sided plates and secure the retaining screws using the small Allen Wrench. **(NOTE: Plate does not firmly contact the side rail.)**

**6**

Unroll your tarp from the head rail to the tailgate. The tonno bows are deployed as the tarp is unrolled.

**7**

Engage the tailgate block and rotate it down to the spring catch.

**8**

Seal the tonno by pressing the velcro® fastening strips from the head end and press all the way back.

Before using any commercial car wash, push down both sides of the Velcro® strips. This will reduce the possibility of water entering the truck bed.

To adjust the tension of the tarp, rotate the screw on the spring block using the large Allen Wrench.

Push up on spring tab to release tonno catch and roll the tonno forward.

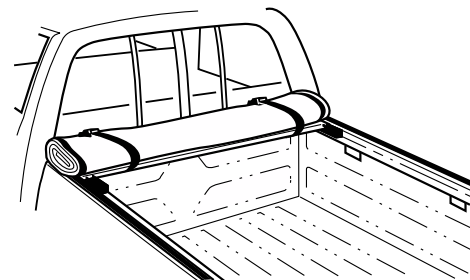

**EASY USE OF TRUCK BED**

Tarp may be rolled up and secured with buckle straps for bulk hauling