



www.riderite.com

OPERATING PRESSURES:	
MINIMUM (UNLOADED)	5 PSI
MAX (LOADED)	35 PSI

READ INSTALLATION INSTRUCTIONS COMPLETELY BEFORE INSTALLING YOUR KIT

INSTALLATION INSTRUCTIONS

Congratulations—your new suspension helpers are quality products capable of improving the handling and comfort of your vehicle while under load. As with all products, proper installation is the key to obtaining all of the benefits your kit is capable of delivering. Please take a few minutes to read through the instructions to identify the components and learn where and how they are used. It is a good idea to start by comparing the parts in your kit with the parts list below.

NOTE: IF ANY PARTS ARE MISSING FROM THE KIT, PLEASE CALL 1-800-888-0650.

PLEASE DO NOT CALL OR RETURN THE KIT TO THE DEALER.

Be sure to take all applicable safety precautions during the installation of the kit. The instructions listed in this brochure and the illustrations all show the left, or driver's side of the vehicle. To install the right side assembly simply follow the same procedures.

VEHICLE PREPARATION

With the vehicle on a solid level surface, chock the front wheels and raise the vehicle using a jack rated for your vehicle's weight. Lift the wheels off the ground. Lower the vehicle frame onto jack stands rated for your vehicles

<p>WARNING</p> <p>Do not inflate this assembly when it is unrestricted. The assembly must be restricted by a coil spring. Do not ever inflate beyond recommended operating pressures for your specific vehicle. Improper use or over inflation may cause property damage or severe personal injury.</p>
--

weight making sure the suspension is fully extended. (Do NOT use wood or concrete blocks to support the weight of the vehicle.) Remove the jounce bumpers located under the frame rail, by prying them out of the jounce bumper cup. The jounce bumpers will not be re-used with this kit but the bolts will be reused.

SHOCK ABSORBERS

If necessary, additional clearance between the coil turns may be obtained by removing the shock absorbers from the lower shock mounts and lowering the suspension an additional one to two inches. (CAUTION: Do not put strain or tension on the flexible brake line.)

PARTS LIST

COIL-RITE AIR SPRING	6130	2
WORK-RITE BUMPER	1258	2
COIL-RITE SUPPORT	0045	2
FACE PLATE	5784	2
SPACER RING	5786	2
CLAMP RING	5785	4
1/2" SPACER	0013	2
1/4" SPACER	5229	2
AIR LINE	0048	1
STRAIGHT FITTING	3439	2

BOLT PACK

3/8"-16 X 1" HEX BOLT	2
3/8"-16 X 2" HEX BOLT	2
3/8"-16 X 1-1/2" FLAT HEAD BOLT	12
3/8"-16 FLANGE LOCK NUT	14
3/8" WASHERS	2
5/16" WASHERS	4
INFLATION VALVE	3098 2
VALVE CAP	3099 2
NYLON TIES	9168 6
THERMAL SLEEVE	0899 2

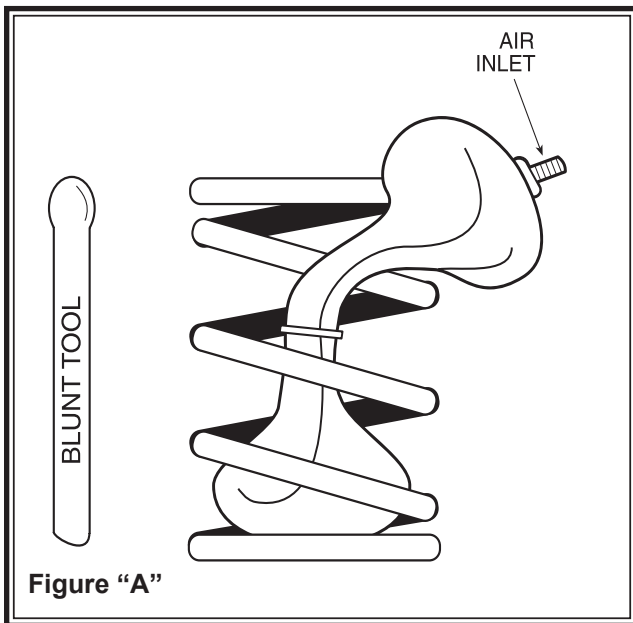

Figure "A"

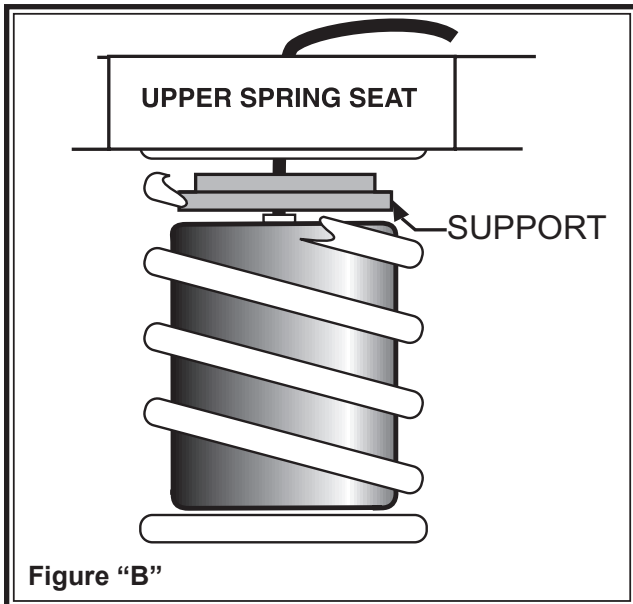

Figure "B"

STEP 1— AIR SPRING PREPARATION (Part # 6130)

Remove the inflation valve cap from the inflation valve on the air spring. Using the valve cap as a core tool from the inflation valve, remove the inflation valve core from the air spring. Exhaust the air spring by pushing it flat then re-insert the valve core back into the air spring to keep it collapsed.

STEP 2—INSTALLING THE AIR SPRING

Insert the top of the flattened air spring into the coil spring through the lowest opening with the inflation valve inlet at the top as shown in *Figure "A"*.

STEP 3—ADJUSTING THE AIR SPRING

Push the air spring up into the coil spring by hand or with a blunt tool. DO NOT use anything with sharp edges or corners as this may damage the air spring.

When the air spring is completely within the coil spring, remove the valve core to let the air back into the air spring. Allow the air spring to return to its normal shape.

Install the spacer on top of the air spring. See *Figure "B"*. Once the weight of the vehicle is applied to the suspension and the air springs are pressurized, the spacer will stay in place.

STEP 4— PREASSEMBLY OF THE WORK-RITE (Part # 1258)

Select one Work-Rite load assist and one face plate (Part # 5641) for the kit. Attach the Work-Rite to the face plate using the 3/8"-16 x 1" hex bolt, flat washer, and lock nut. See *Figure "C"*.

NOTE: An optional spacer may be installed to engage the Work-Rite sooner when a load is applied. To install, place between the Work-Rite and the face plate. If the spacers are installed, use the 3/8"-16 x 2" bolts instead of the 3/8"-16 x 1" bolts. There should be 1/4" to 3/8" between the Work-Rite and the jounce stop. See *Figure "D"*.

STEP 5— INSTALLING THE ASSEMBLY ONTO THE VEHICLE

Select one spacer ring from your kit and place it around the jounce bumper cup. Place the assembly against the bottom of the jounce bumper cup and align the holes in the face plate with the holes in the spacer ring. Place the clamp rings on top of the space ring, aligning the holes. Insert the 3/8"-16 x 1-1/2" flat head bolts into the tapered holes on the face plate and secure to the clamp ring with the flange lock nuts. See *Figures "C" & "D"*.

STEP 6— REATTACH THE SHOCK ABSORBER

Attach shock absorbers if removed earlier in the installation. Torque to manufactures specifications.

STEP 7— ROUTE THE AIR LINE

Cut the remaining air line tubing into two equal lengths (cut the tubing as squarely as possible). Select a location for the inflation valves in a protected area, such as the bumper or fuel fill floor (**Note:** The inflation valve will be installed in Step 8).

Insert the air line tubing into the push-to-connect fitting on the air spring as far as possible. Route the tubing from the air spring to the inflation valve, making sure to avoid direct heat from the engine, exhaust pipe and away from sharp edges. Secure with Nylon ties provided in your kit.

Figure "C"

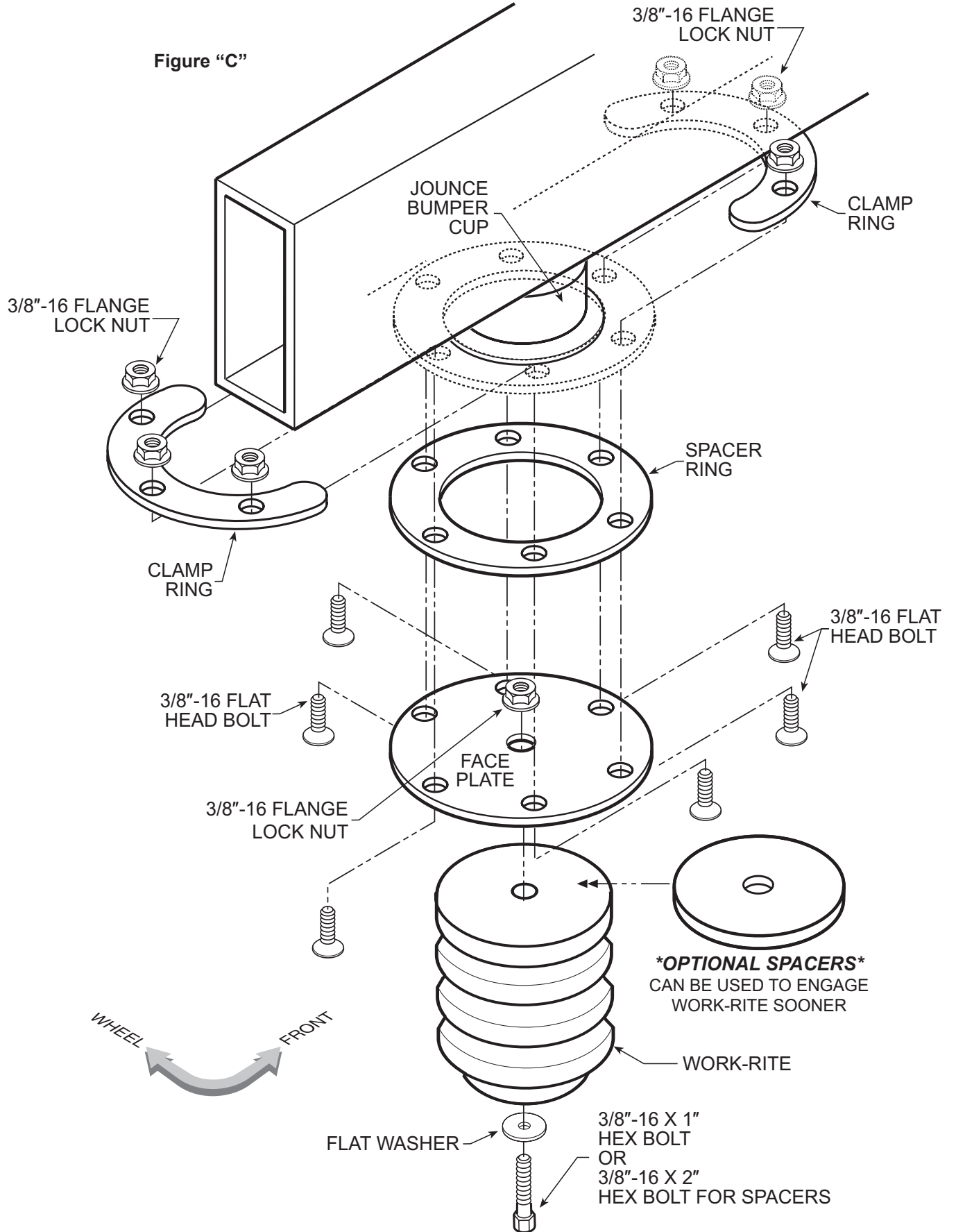

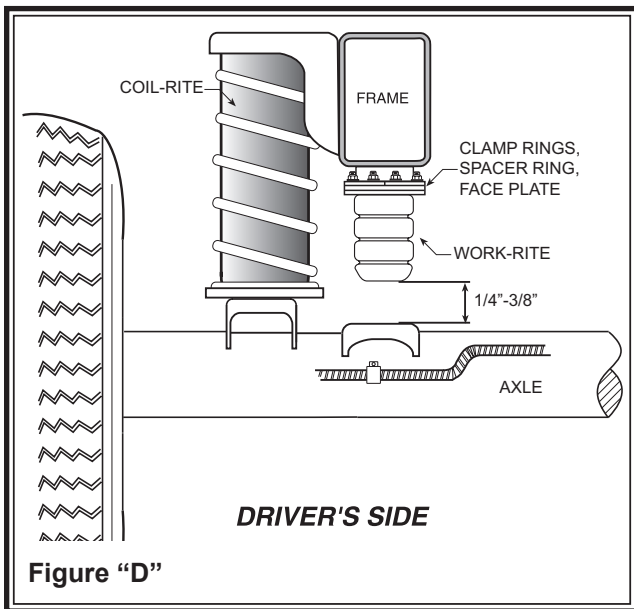

STEP 8—INSTALL THE AIR LINE AND INFLATION VALVE

Select a location on the vehicle for the air inflation valves. The location can be located on the bumper or the body of the vehicle, as long as it is in a protected location so the valve will not be damaged, but maintain accessibility for the air chuck **see Figure "E"**. Drill a 5/16" hole and install the air inflation valve using two 5/16" flat washers per valve as supports **see Figure "F"**.

FOLLOW STEPS 1-8 FOR THE OTHER SIDE OF THE VEHICLE.

STEP 9—INFLATE AND TEST

Inflate the air springs to recommended operating pressure (see page 1 for operating pressures). With a soap and water solution, check for air leaks around the fittings and valve core. We recommend inflating and deflating in 5 psi increments to find the ideal riding condition for your vehicle.

STEP 10—COMPLETION

This now completes the installation. Install. Raise the vehicle and remove the jack stands and lower the vehicle back onto the ground. Inflate the Coil-Rite air helper springs to 5 psi.

NOTE: Check air pressure on a monthly basis.

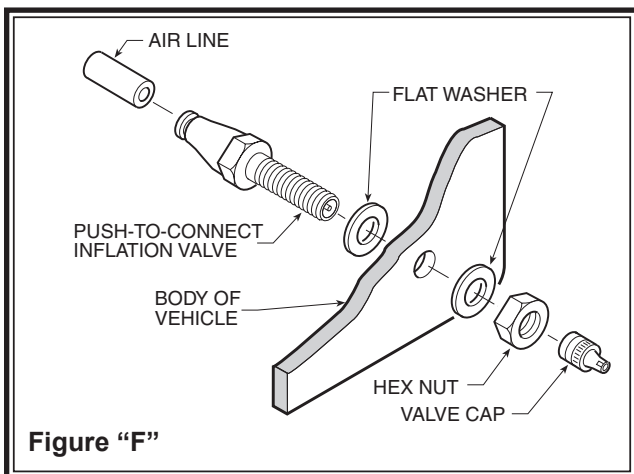
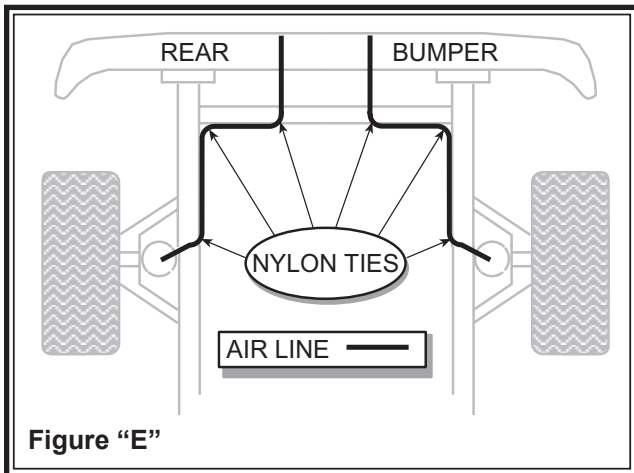



Do Not Return This Product to the Dealer or Distributor

If you are

- missing parts,
- experiencing installation problems, or
- have technical concerns regarding this product,

you may contact a Firestone Technical Service Representative at rrtech@fsip.com or at 800-888-0650 (option 1, and then option 2). Representatives are available from 7:30 a.m. – 4:30 p.m. Eastern on Monday – Friday, excluding holidays. If you are located outside of the United States, you should first contact your distributor or dealer directly with any issues.

When contacting Technical Service, please have the kit or part # ready, along with the make, model, and year of the vehicle. You may also need to provide details, such as 2WD/4WD or if the vehicle has been lifted or lowered from stock height.

If you have a warranty concern, please include in your email a detailed description of the situation, a photo(s) of the issue, and your contact information, including ship-to address.

WARRANTY COVERAGE*— The Ride-Rite™ kits, components, and accessories are warranted against defects in workmanship and materials. This warranty does not cover service or labor charges, neglect...to the product.

PERIOD OF COVERAGE:

- | | |
|---|--|
| • Ride-Rite air springs – Lifetime Limited | • Work-Rite load assists – 2 Years Limited |
| • Sport-Rite air springs – Lifetime Limited | • Air-Rite accessories – 2 Years Limited |
| • Coil-Rite air springs – Lifetime Limited | • Brackets, hardware, fittings, air line, and other components – 2 Years Limited |
| • Level-Rite air springs – Lifetime Limited | |

HOW TO MAKE A WARRANTY CLAIM — If you purchased your air springs in the U.S. or Canada and believe you have a part with a warrantable defect, call Firestone directly at 1-800-888-0650.

International customers should contact their distributors or dealers directly with any problems.

(*) Please refer to the “Firestone Limited Lifetime Air Spring Warranty” for details, terms, and conditions.

FIRESTONE LIMITED LIFETIME AIR SPRING WARRANTY

Firestone Industrial Products Company LLC ("Firestone") warrants that its Ride Rite Air Spring Assembly will perform according to the manufacturer's specifications for as long as the vehicle on which the system was originally installed is owned by the original retail purchaser. This limited warranty does not include installation or other service charges for replacement.

Warranty Period

The Air Spring is warranted for as long as the original purchaser owns the vehicle on which it was originally installed. The fasteners and upper and lower brackets which accompany the air spring are warranted for a period of twenty-four (24) months or 24,000 miles whichever occurs first. This warranty begins on the original retail delivery date.

What is Covered

Any implied warranties are limited in duration to the coverage period of this warranty (some states do not allow limitation on how long an implied warranty lasts so the above limitation may not apply to you). This Warranty runs in favor of the original retail purchaser when the Ride Rite Air Spring Assembly is used under normal operating conditions according to Firestone's specifications and installed on the appropriate application. This warranty does not apply to Ride Rite Air Spring Assemblies that have been improperly applied, improperly installed, used in racing or off road applications or used for commercial purposes. In addition, the warranty will not apply to products which have not been maintained and serviced according to the instructions that accompany the air spring assembly. The consumer will be responsible for any costs incurred in removing the product from the vehicle and the cost to return the air spring assembly to the dealer or installer from which it was purchased. If it is determined that the Ride Rite Air Spring Assembly failed as a result of a manufacturing defect, Firestone will repair or replace, at its option, any product or components subject to this warranty. You should retain a copy of your contract with your installer and your receipt as proof of the date of installation. This warranty is non-transferable and is not assignable in any way.

Firestone specifically excludes any obligation for consequential damages or incidental expenses including claims for loss of use of the product, loss of time, inconvenience, or commercial loss. This warranty gives you specific legal rights. You may also have other rights that may vary from state-to-state. Some states do not allow limitations on how long an implied warranty lasts or allow the exclusion or limitation of incidental or consequential damages. The above limitation or exclusion may not apply to you. There are no warranties, express or implied, including implied warranty of merchantability and fitness which extend beyond this warranty.

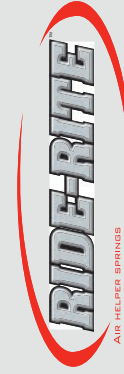

Firestone
World's Number 1
Air Spring.



FIRESTONE INDUSTRIAL PRODUCTS COMPANY