



THE PERFORMANCE EXHAUST COMPANY™

11170 FLOWTECH I® - STANDARD FINISH HEADERS

31170 FLOWTECH II® - CERAMIC FINISH HEADERS

**1970-1979 PONTIAC FIREBIRD/TRANS AM
1964-1975 PONTIAC GTO, LE MANS, GRAND AM
WITH 326-455 PONTIAC ENGINE**

WILL NOT FIT FIREBIRD/TRANS AMS WITH COLUMN SHIFTED STANDARD TRANSMISSION

We Realize that you had many choices when you chose your headers, we thank you for purchasing FLOWTECH®. At FLOWTECH® we put our many years of performance exhaust experience into every product we build. We know you will agree, FLOWTECH® Headers are the best you can buy at any price.

As a result of the restricted room available in some engine compartments, you may experience a close fit to some body and chassis components. This is a normal condition. If this is your first time installing a set of headers, it may be time consuming. While not complex, stick with it. As soon as you start your engine, the reward of additional horsepower and performance will be well worth your efforts. Proper installation and periodic maintenance will result in maximum performance and life from your headers.

READ THESE INSTRUCTIONS CAREFULLY BEFORE STARTING:

For ease of installation, your vehicle must be raised a minimum of 36". Warning: should you decide to install any exhaust yourself, be warned that the original equipment jack that came with the vehicle is intended for emergency use only. The use of a frame jack in conjunction with a floor jack as main support is highly recommended to minimize the accidental dropping of a vehicle while the installation proceeds. Never go under any vehicle that is supported by a bumper jack!

1. PREPARE THE CAR FOR INSTALLATION:

- A. Disconnect the battery to prevent accidental damage to the electrical system.
- B. Remove the stock exhaust manifolds.
- C. Remove the starter and clutch linkage (if equipped).
- D. On 75 Le Mans: Remove the solenoid heat shield and discard.
- E. Remove the oil filter assembly from the block.
- F. Remove the shift linkage, steering lockout device, and chassis support rods on later vehicles.

2. CHECK THE CONDITION OF THE ENGINE MOUNTS

It is recommended that new engine mounts be installed before installing headers.

3. LEFT SIDE HEADER INSTALLATION:

- A. Remove the center bolt from engine mount, using a floor jack with a board under the oil pan. Raise the engine 2-3".
- B. Starting from below, work the header into position over the exhaust ports. Start the front bolt.
- C. Lower the engine and reattach the engine mount.

INSTALLATION NOTE: It may be necessary on earlier models to add spacers to raise the engine mount ¼-½" for header-to-crossmember clearance.

- D. With the header still loose, replace the clutch linkage, if necessary.
- E. Remove the front bolt and place the gasket into position. Install the bolts, doing the most restricted ones first. Tighten all header bolts progressively and evenly until they are tight.

INSTALLATION NOTE: If necessary, relocate the brake line junction block slightly for proper header clearance. Some models may require modification or complete removal of the splash pan.

- F. Reinstall the starter and shift linkage.

INSTALLATION NOTES:

- 1. Late models, modify the shifter linkage and steering lock out device per illustrations "A", "B", and "C". On 76 Trans Ams, discard the reverse lockout rod. The lockout linkage must be secured in a position that will not lock the steering wheel.
- 2. In order to retain the TAC heat to the carburetor, modify the heat stove as per illustration "D".
- 3. Late model vehicles, discard the chassis support rods.
- 4. For added clutch linkage clearance, modify as per illustration "E". For more clearance, call Classic Muscle at 1-800-722-4828 to purchase a cross shaft (P/N 3920615).
- 5. Check clearance between upper A-arm and header. If the header contacts the A-arm bolt, trim the bolt. If the header tubes contact the upper A-arm, mark and trim the A-arm for clearance.

4. RIGHT SIDE HEADER INSTALLATION:

- A. Remove the center bolt from engine mount, using a floor jack with a board under the oil pan. Raise the engine 2-3".
- B. Starting from below, work the header into position over the exhaust ports. Start the front bolt.
- C. Lower the engine and reattach the engine mount.

INSTALLATION NOTE: It may be necessary on earlier models to add a spacer to raise the engine mount ¼-½" for header to crossmember clearance.

- D. Replace the oil filter.

INSTALLATION NOTE: On 75 Le Mans models, it may be necessary to dent the #4 tube slightly for clearance.

- E. With the header still loose, replace the clutch linkage, if necessary.
- F. Place the gasket into position. Install the bolts, the most restricted ones first. Tighten all header bolts progressively and evenly until they are tight.

INSTALLATION NOTES:

- 1. On automatic transmission equipped vehicles, reroute transmission coolant lines for clearance.
- 2. For clearance to the oil pressure sending unit, use a 45° adapter.
- 3. Check clearance between upper a-arm and header. If the header contacts the a-arm bolt, trim the bolt. If the header tubes contact the upper a-arm, mark and trim the a-arm for clearance.

5. AFTER HEADERS ARE IN PLACE:

- A. Inspect all points with limited clearance. Relocate any points that have direct contact with the headers. Make sure there is adequate clearance around all lines (transmission, brake, fuel and electrical wires). Reroute as necessary. Before installing your exhaust system, replace any fluids that you may have removed or lost.
- B. Reconnect the battery cable.

6. CONNECT THE EXHAUST SYSTEM:

- A. Bolt the reducers and gaskets to the header collectors.
- B. Attach the exhaust system by either welding or clamping the exhaust pipes to the reducers

When you have finished installing your *FLOWTECH*® Headers, take the vehicle for a road test. Listen carefully for any exhaust leaks or other strange noises and make corrections. When the vehicle has been driven for a few days, retighten the header bolts. We find that periodically checking the bolts will prevent the flange from warping and the burning out of the header gaskets.

ILLUSTRATION "A"

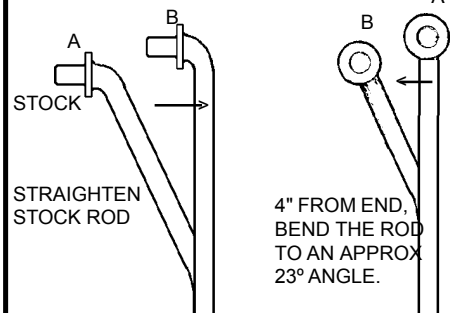

ILLUSTRATION "D"

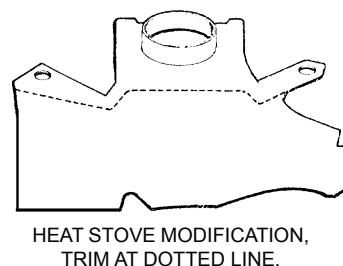

ILLUSTRATION "B"

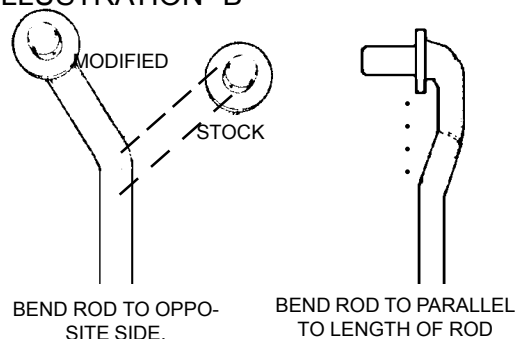

ILLUSTRATION "E"

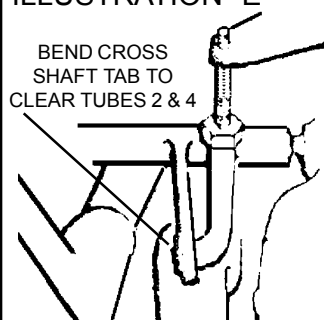
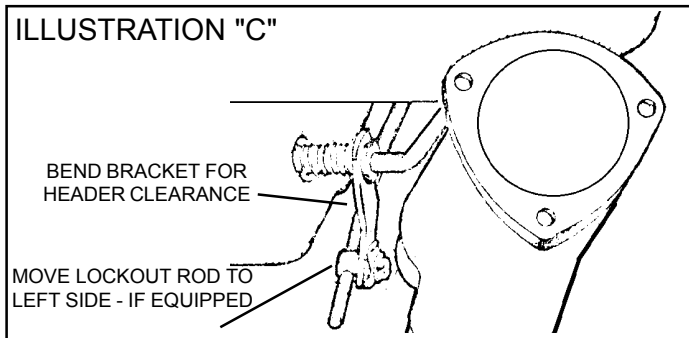

ILLUSTRATION "C"



LIMITATION OF LIABILITY - DISCLAIMER: THE REGULATION OF EMISSIONS PRODUCTION, NOISE LEVELS AND SAFETY STANDARDS IS UNDERTAKEN BY THE FEDERAL GOVERNMENT, EACH OF THE FIFTY STATE LEGISLATURES AND BY MANY LOCAL MUNICIPALITIES, TOWNS AND COUNTRIES.

FLOWTECH® MAKES NO WARRANTIES OF MERCHANTABILITY, OF FITNESS FOR PARTICULAR PURPOSE. OR THAT ITS PRODUCTS ARE APPROVED FOR GENERAL USE, OR THAT ITS PRODUCTS COMPLY WITH LAWS, REGULATIONS OR ORDINANCES IN THE STATES WHERE THEY MAY BE SOLD TO THE ULTIMATE PURCHASER, THE CONSUMER.

UNLESS EXPRESSLY STATED TO THE CONTRARY IN THE *FLOWTECH*® CATALOG, INSTRUCTION SHEET OR PRICE LIST, THE ENTIRE RISK AS TO THE CONFORMITY OF ANY COMPANY PRODUCT IN ANY SUCH STATE AND AS TO REPAIR SHOULD THE PRODUCT PROVE TO BE DEFECTIVE OR NONCONFORMING, IS ON THE RETAIL PURCHASER, THE BUYER, THE ULTIMATE CONSUMER, OF SUCH PRODUCT AND IT IS NOT UPON THE SELLER, DISTRIBUTOR OR MANUFACTURER.

IN THE CONNECTION, RETAIL PURCHASER, THE BUYER, THE ULTIMATE CONSUMER ASSUMES THE BURDEN OF THE ENTIRE COST OF ANY AND ALL NECESSARY SERVICE, ALTERATIONS OR REPAIR.

THE FOREGOING STATEMENT LIMITS THE LIABILITY OF THE MANUFACTURER. CALIFORNIA VEHICLE CODE SECTIONS 27156 AND 38391 PROHIBIT THE ADVERTISING. OFFERING FOR "SALE OR INSTALLATION OF ANY DEVICE WHICH MODIFIES A VEHICLE'S EMISSIONS CONTROL SYSTEM UNLESS EXEMPTED. UNLESS OTHERWISE NOTED, *FLOWTECH*® HEADERS HAVE NOT RECEIVED AN EXEMPTION FROM THESE CODE SECTIONS AND ARE NOT LEGAL FOR SALE OR USE IN CALIFORNIA ON VEHICLES ORIGINALLY EQUIPPED WITH CATALYTIC CONVERTERS. IT IS ILLEGAL, EXCEPT FOR RACING VEHICLES WHICH MAY NEVER BE DRIVEN UPON A HIGHWAY, TO REMOVE OR OTHERWISE RENDER INOPERATIVE ANY EMISSION CONTROL DEVICE ON REGULATED MOTOR VEHICLES (CHECK CATALOG LISTINGS TO INSURE PROPER APPLICATION). IN THE OTHER 49 STATES UNLESS OTHERWISE NOTED, *FLOWTECH*® HEADERS ARE NOT LEGAL FOR POLLUTION CONTROLLED MOTOR VEHICLES, EXCEPT FOR RACING VEHICLES WHICH MAY NEVER BE USED UPON A HIGHWAY AND ARE NOT INTENDED OR APPLICABLE FOR HIGHWAY USE.

HOW DID WE DO? YOUR QUESTIONS AND COMMENTS ARE ALWAYS WELCOME AT *FLOWTECH*. OUR TECHNICAL SERVICES DEPARTMENT IS OPEN MONDAY THROUGH FRIDAY, DURING THE HOURS OF 8:00 A.M. UNTIL 5:00 P.M. CENTRAL TIME. WE CAN ALSO BE REACHED AT:

FLOWTECH[®]
by **Holley**[®]

THE PERFORMANCE EXHAUST COMPANY™
P.O. Box 10360, Bowling Green, KY 42102-7360
Technical Service: 270-781-9741 or Fax: 270-781-9771
For online help, please refer to the Tech Service section of our
website: www.holley.com