

FLOWMASTER™

AMERICAN THUNDER™

SYSTEM # 17107

1964-1972 GM "A" BODY

MUFFLERS NOT INCLUDED

9/2/05

Removal:

- 1) Raise vehicle and support with jackstands.
- 2) Remove the existing exhaust system from the headers or manifold down pipes back.

Installation:

- 1) Bolt adapter plate #HA242 to hanger #'s HA240 and HA241 using the 5/16" x 3/4" bolts and nuts provided in the parts kit . **See detailed drawing in figure 1.**
- 2) On the frame of the vehicle, slightly forward of the rear axle, there are a set of two mounting holes on each side of the vehicle which will be used to mount the rear muffler hangers. Use these stock locations to mount hanger #HA240 on the left side and hanger #HA241 on the right. Use the 5/16" x 1" bolts and nuts provided. **See detailed drawing in figure 1.**
- 3) Place H-pipe assembly #16008 in its approximate position underneath the vehicle and support with a stand.
- 4) Connect the inlet of the mufflers to the rear of the H-pipe. Then place the outlets of the mufflers into the rear muffler hangers #HA240 and HA241, be sure that the mufflers are sitting level. Use jack stands to hold their position. The outlet of the muffler should be offset toward the outside of the vehicle.
(Note:when using 50 series mufflers the rear of the h-pipe assy. #16008 must be trimmed back 2.00" on each side to accept the longer muffler.)
- 5) Place the right tailpipe #16155 in position over the axle on the right side of the vehicle. Place the left tailpipe #16154 in position over the axle on the left side of the vehicle. When installing tailpipes, the rear of the vehicle must be supported by the frame with jack stands, allowing the axle to hang from the suspension. **NOTE:** The car should be supported by the axle after the tailpipes are in place.
- 6) Bolt the tailpipe hangers #HA151 in the stock location on the rear quarter frame rails using the 5/16" x 1" nuts, bolts and washers provided. (The holes may need to be drilled out to except the 5/16" bolts).
- 7) With two (2) of the 2 1/2" clamps provided, connect the tailpipes to the rubber hangers to

support the tailpipes.

- 8) Insert the tailpipes into the muffler outlets and adjust the mufflers and tailpipes into their approximate final position.
- 9) The front connector pipes are long enough to allow for many different header combinations, therefore, it is necessary to determine the proper length of the inlet connector pipes . Once the proper length is determined, trim the front connector pipes .
- 10) Once the pipes are cut to the proper length, raise them into position and connect them to the H-pipe and header collectors or manifold down pipes using a standard Header Flange or FLOWMASTER Venturi Cone.
- 11) Adjust the position of the mufflers and all pipes to provide the proper fit.
- 12) Make any final adjustments to the position of the mufflers and pipes before tightening down securely. Be sure to allow adequate clearance for full suspension travel and vibration.

NOTE: WE STRONGLY RECOMMEND WELDING ALL SLIP-FIT CONNECTIONS.

Packing List

<u>Qty.</u>	<u>Part # or Size</u>	<u>DESCRIPTION</u>
2	16157	Connector Pipe, (R/L)
1	16008	H- Pipe Assembly
1	16155	Tailpipe, Right
1	16154	Tailpipe, Left
2	16156A	Straight Exit Pipe
2	16156B	Bent Exit Pipe
1	PK119	Parts kit
8	MC250S	2 ½" Clamps
1	HA240	Muffler Hanger (L)
1	HA241	Muffler Hanger (R)
2	HA242	Adapter Plate (R/L)
2	HA151	Tailpipe Hanger (R/L)
4	5/16" x3/4"	Bolts
6	5/16" x 1"	Bolts
10	5/16"	Nuts
4	5/16"	Fender Washers
10	5/16"	Lock Washers
6	5/16"	Flat Washers
1		Instruction Sheet

FIGURE 1.

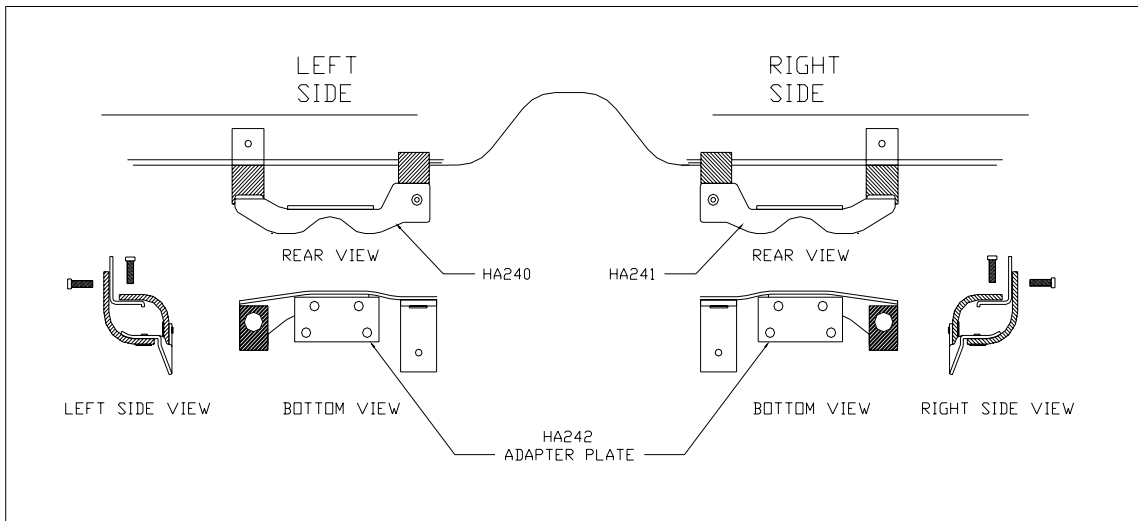

FLOWMASTER UNIVERSAL PIPE KIT #17107

1964-72 GM A-BODIES

