



FORCE II

ITEM	PART NO.	DESCRIPTION	QTY.
1	26907S	HEAD PIPE	1
2	26277S	EXTENSION PIPE	1
3	8530552-Z	FORCE II MUFFLER	1
4	86323S	LEFT OVER-AXLE PIPE	1
5	86327S	RIGHT OVER-AXLE PIPE	1
6	86324S	LEFT TAILPIPE	1
7	26629S	REAR EXIT PIPE	2
8	ST462	TIP, STAINLESS STEEL	2
9	490HA	CLAMP HANGER	1
10	MC300BS	CLAMP, STAINLESS, 3"	2
11	MC250BS	CLAMP, STAINLESS, 2-1/2"	5
12	SF059	FLANGE	1
13	HW103	NUT, 3/8-16	1
14	HW309	LOCK WASHER, 3/8"	1
15	525HA	FRAME HANGER	1
16	HW234	BOLT, 3/8-16 x 3-1/2"	1
17	HA566	BACKING PLATE	1
18	HA168	HANGER, RUBBER	1
19	HW502	HANGER KEEPER, 7/16"	2
20	HW505	CABLE TIE, 15"	1

Installation Instructions

818148

2021-23 FORD F-150 with 2.7L,
3.5L, and 5.0L ENGINE

2- or 4-WHEEL DRIVE, ALL EXCEPT

122" WHEELBASE (REGULAR CAB, 6 1/2' BED)

See "Applications" tab on the product web page for specific applications.

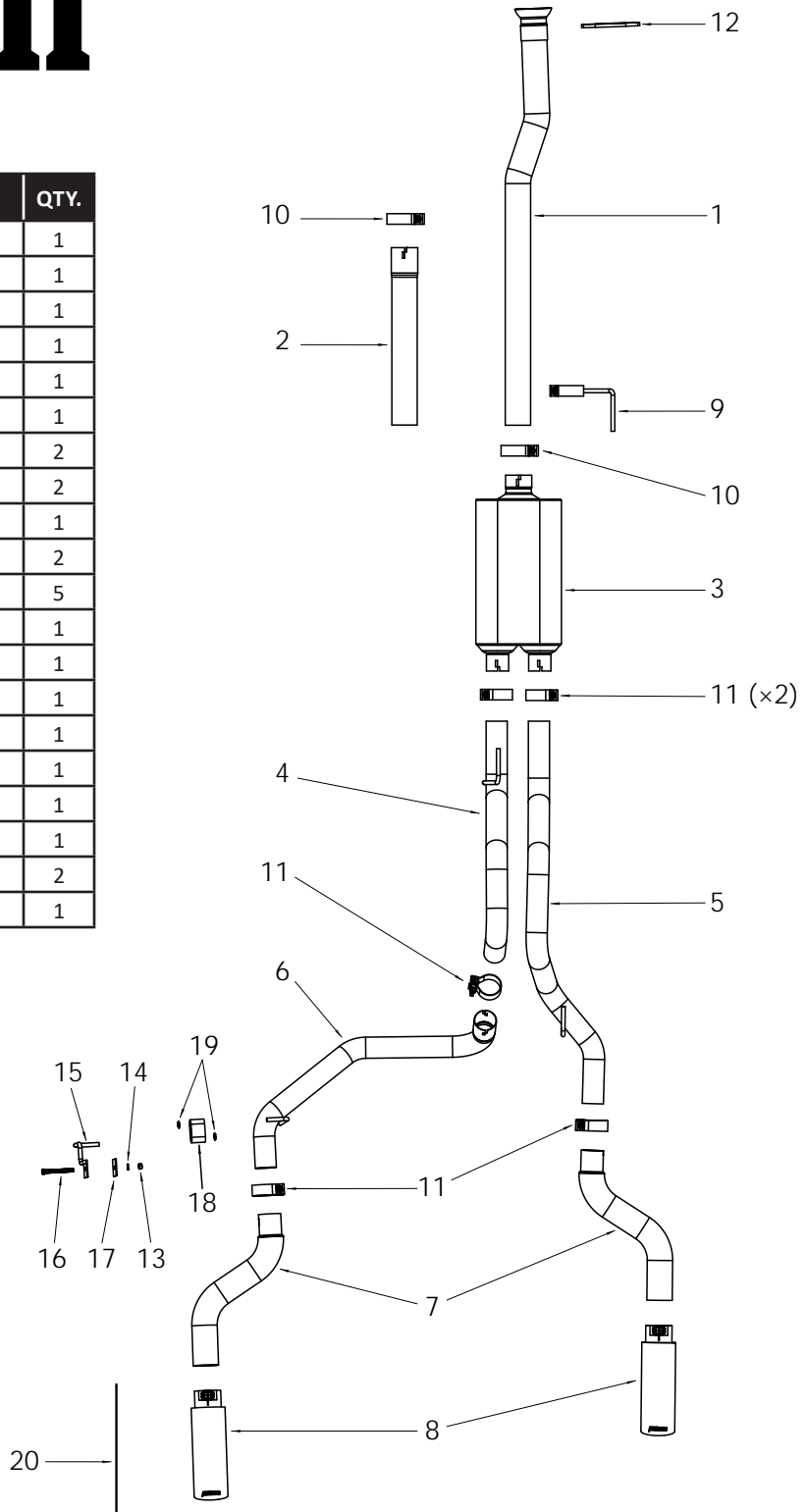

NOTES

- Installation requires moderate mechanical skill. If this job is beyond your abilities, seek the services of a qualified technician.
- If you do not understand any part of these instructions, please call Flowmaster Technical Support at (866) 464-6553 for assistance.
- Use stands to support exhaust system components, both when removing the stock system, and when installing your new kit.
- Apply penetrating oil generously to clamps, fasteners, pipes, and hanger rods for ease of disassembly.

REVIEW THE INSTRUCTIONS & VERIFY THE KIT CONTENTS

Take a moment to read and understand these instructions before installing your Flowmaster Force II exhaust kit.



Use the parts drawing and list to verify your kit's contents. In the unlikely event that any parts are missing, please contact Flowmaster Technical Support for replacements.

REMOVE THE FACTORY EXHAUST SYSTEM

WARNINGS

- **AVOID BURNS!** Exhaust systems get extremely hot. Allow the vehicle to cool down fully before starting work.
- **AVOID SERIOUS INJURY OR DEATH BY CRUSHING!** Never work under a vehicle that is supported by jacks.

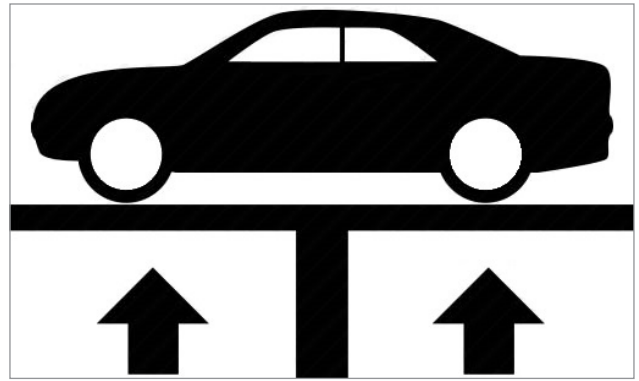

1. **Raise the vehicle** to working height on a lift. If you do not have a lift, securely support the vehicle on jack stands.

NOTE: If a lift is used, the entire stock exhaust system can be removed, whole, by two persons. But cutting the tailpipe off makes removal easier, especially if the job is performed on jack stands.

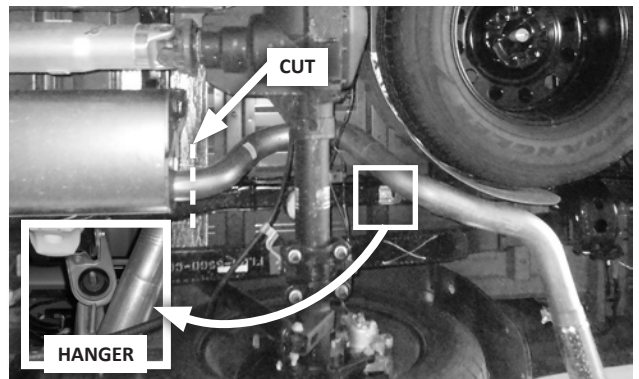

2. **Cut the tailpipe off just behind the muffler.** Disengage the tailpipe's hanger rod from its rubber isolator, and remove the tailpipe from the vehicle.



3. **Remove and retain the 2 fasteners** from the inlet pipe flange.

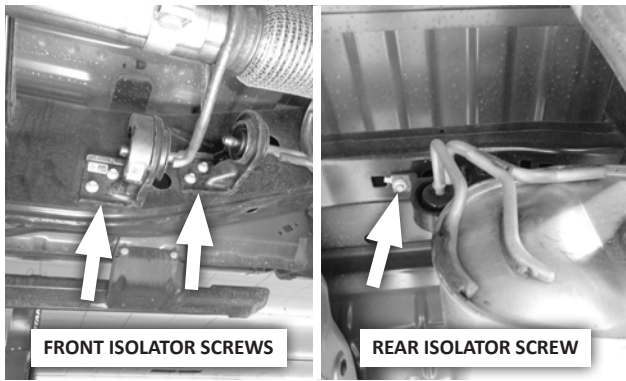

4. Remove the screws from the muffler's front and rear isolators. Then remove the assembled inlet pipe, muffler, and isolators from the vehicle.

INSTALL YOUR FLOWMASTER EXHAUST SYSTEM

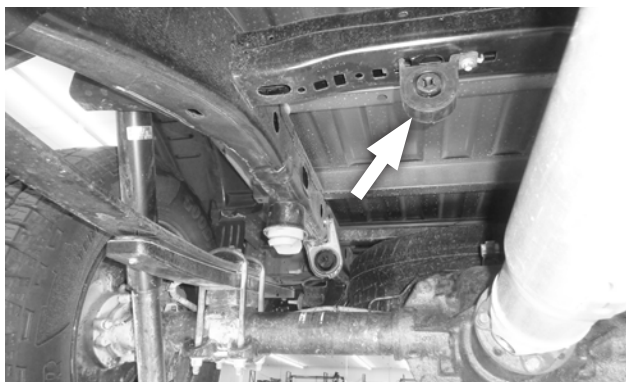

5. Remove the isolators from the muffler, then reinstall the rear isolator on the frame. (One front isolator will be installed later.)

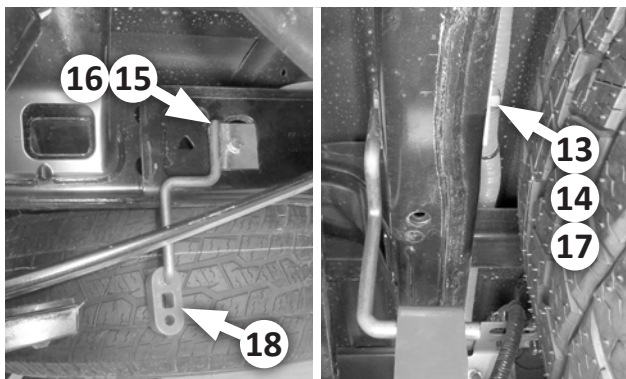

6. On the driver's side frame (between the leaf spring and spare tire), install **frame hanger (15)** using the **3-1/2" bolt (16)** (on outside of frame), and **backing plate (17)**, **lock washer (14)**, and **nut (13)** (on inside of frame). Lightly snug the fasteners (to allow final adjustment later). Lastly, slide **rubber hanger (18)** onto the rod.

CAB	BED	WB	HEAD PIPE MOD	PARTS REQUIRED
Regular	8'	141"	CUT BACK 4"	Head pipe only
Super	6½'	145"	Not required	Head pipe only
Super Crew	5½'	145"	Not required	Head pipe only
Super Crew	6½'	157"	CUT BACK 6"	Head pipe + extension
Super	8'	164"	Not required	Head pipe + extension

7. Use this table to determine:
 - A. if your **head pipe (1)** needs to be modified; and
 - B. if your truck requires the **extension pipe (2)**.

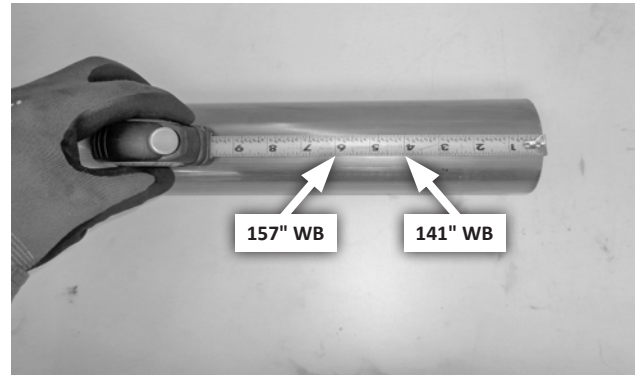

8. FOR 141" AND 157" WHEELBASE TRUCKS: Cut the head pipe back as specified in **Step 7**.

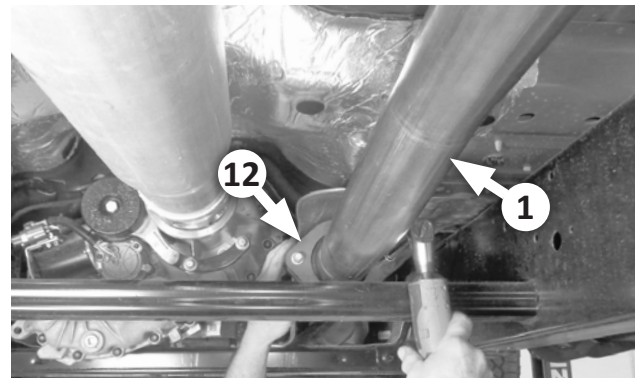

9. Slip flange (12) over the head pipe (1), then attach the head pipe to the catalytic converter flange using the stock fasteners. Lightly snug the fasteners (to allow final adjustment later).



10. Before installing any clamps, remove their nuts, apply anti-seize compound to the bolt threads, and re-install the nuts.

NOTE: All **pipe-to-pipe** slip-fit connections must seat **3" deep**. All **pipe-to-muffler** connections must seat **2" deep**. Mark the male ends of each pipe in advance, to ensure proper insertion during assembly.

11. FOR 157" AND 164" WHEELBASE TRUCKS: Slip a **3" clamp (10)**, and **extension pipe (2)**, onto the head pipe. Verify 3" of insertion, and snug the clamp slightly (to allow final adjustment later).

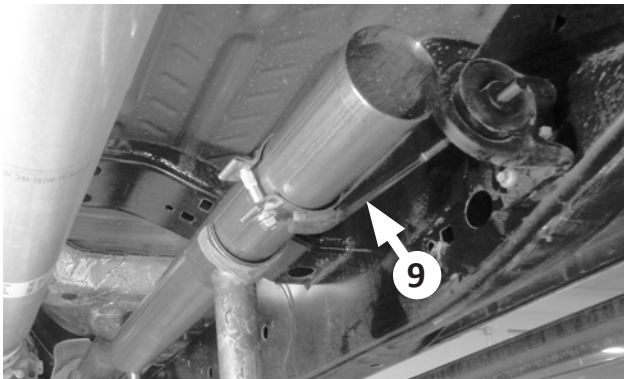

12. Slide clamp hanger (9) over the head (or extension) pipe. Slip a front isolator over the hanger rod, and use the stock screws to attach it to whichever frame location gives the best fit for your truck. Snug the screws and clamp lightly (to allow final adjustment later).

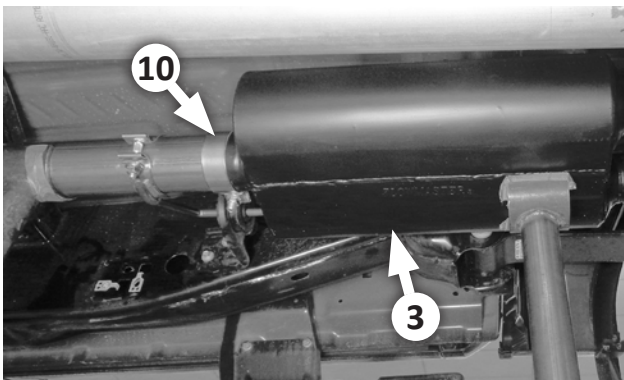

13. Slip a 3" clamp (10) onto the head (or extension) pipe. Slip **muffler (3)** onto the pipe, support it with a stand, verify 2" of insertion, and snug the clamp slightly.

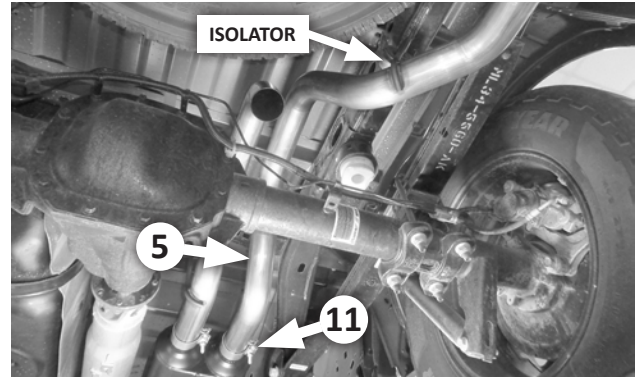

14. Slip a 2-1/2" clamp (11) over the muffler's right outlet. Move the **right over-axle pipe (5)** into place, and slide its hanger rod into the isolator. Then slip the end of the pipe into the muffler's outlet, verify 2" of insertion, and snug the clamp slightly.

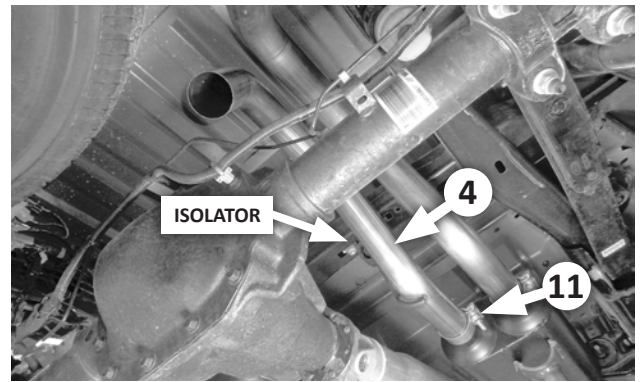

15. Slip a 2-1/2" clamp (11) over the muffler's left outlet. Move the **left over-axle pipe (4)** into place, slide its hanger rod into the isolator, and slip the end of the pipe into the muffler's outlet. Verify 2" of insertion, then snug the clamp slightly.

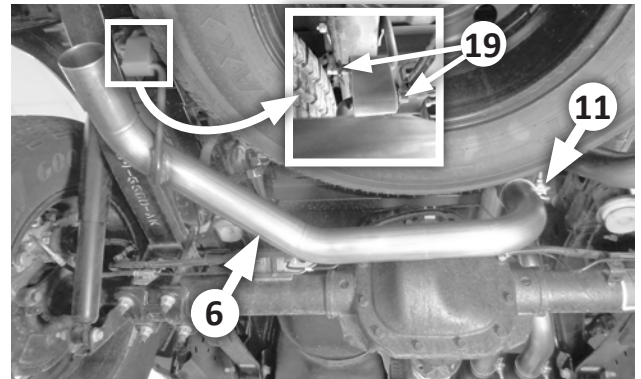

16. Slip a 2-1/2" clamp (11) over the front of the left tailpipe (6), and move the pipe into place. Slip it onto the left over-axle pipe, slide its hanger rod into the rubber hanger installed at **Step 6**, and install the two **hanger keepers (19)**. Verify 3" of insertion, and snug the clamp slightly.

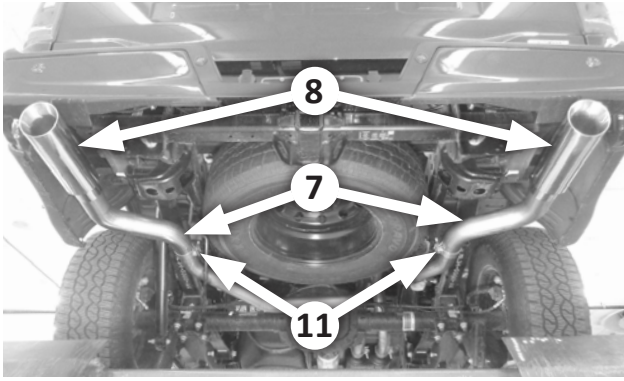

17. Slip a 2-1/2" clamp (11) over each rear exit pipe (7), and install each one on its tail pipe. Align each exit pipe as desired, verify 3" of insertion, and snug each clamp slightly. Install a tip (8) on each rear exit pipe. Align each tip as desired, and tighten its clamp.

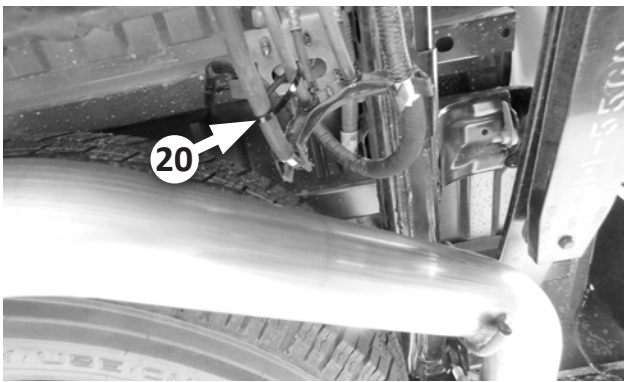

18. Adjust all components to give 1/2" to 3/4" clearance (about a finger's width) around them, and allowing for suspension travel and vibration. (If necessary, relocate the front isolator and clamp hanger, installed at Step 12.) When you are satisfied with the system's clearance and fit, tighten all clamps and hardware. Use cable tie (20) to keep electrical and fluid lines away from exhaust components.

RECOMMENDED: Tack weld each slip-fit connection (approx. 1" weld) for added security, then paint each weld with high-temp spray paint to protect against corrosion.



Congratulations, the installation of your Flowmaster Force II performance exhaust system is complete!

KEEP THESE INSTRUCTIONS FOR FUTURE REFERENCE

Flowmaster maintains a highly-trained technical service department to answer your technical questions, provide additional product information and offer various recommendations.



FLOWMASTER TECHNICAL SUPPORT: (866) 464-6553