

Input Voltage	Max Pods Per Zone	LED Pod Wattage
12V DC	14 Pods	6 watt (14W strobe)

Warranty and Disclaimer

Within THREE years after the purchase date, the original buyer may return any Switch Box that has failed due to a defect in materials or workmanship. LED Pods that have one or more LEDs fail to illuminate due to a defect in materials or workmanship are covered with a THREE year warranty for **the original buyer**.

Installation of this product must be performed by a licensed professional. Should the failure of the product be the result of damage occurring as a result of improper installation, alteration of the product or an act or omission on the part of the consumer, this warranty is void. XKGLOW Lighting shall not be responsible for any consequential damages which arise from the use and/or installation of the product. If the kit is installed in any manner other than specified, XKGLOW Lighting reserves the right to deny any warranty claims at the discretion of the technical support department. Any product return must include the original packaging, invoice number and a statement of the alleged defect. Upon receipt of the returned product, the company will test the product for defect. If the results of the testing do not support the warranty claim, do not reveal any defect or indicate consumer negligence in the installation and handling of the product, then the product will be returned to you and you will be charged a reshipping fee. If the product is returned from an address within the continental United States, within the first 30 days after purchase, and is found to be defective, XKGLOW Lighting will exchange or refund the original purchase expense. This offer does not extend to the cost for shipping charges on any international packages.

Additional Disclaimer Terms

Please check your local and state laws for the proper use of this product.

- Improper installation of electrical products such as lighting may cause damage to any vehicle or device to which the improperly handled or installed lighting is attached.
- Improperly installed product may cause electrical injury to persons.
- It is recommended that the kit should be installed by a licensed professional.
- XKGLOW assumes no liability for the installation of the product.
- Warranty or liability will not exceed the product purchase price, which shall be buyer's sole and exclusive remedy.

Return/Exchange Procedure

1. Email [xk@xkglow.com] to notify us of the product issue as well as the item number and name of customer on invoice.
2. We will send you the trouble-shooting guide to fix the issue, or to narrow down which of the component(s) need to be replaced. If the issue still exists, we will ask you to send back the defective items to be replaced.
3. Please send the returned item as instructed, along with claims and a telephone number where you can be reached.
4. After the returned item(s) have been accepted and inspected, we will issue a refund or replace the items ASAP. For refunds, item(s) must be sent to XKGLOW within 14 days from date of purchase. Original shipping charges are not refundable.

We always stand behind our products and are committed to our customers! For questions you may have, please contact xk@xkglow.com. We normally respond within 24 hours. (Monday-Friday).

Mounting Instructions

- Test all components before mounting:** As shown below, plug ALL light units together and connect them to the controllers and the switch box. Connect the RED wire to the POSITIVE pole of 12V DC battery. Connect the BLACK wire to the NEGATIVE pole. Turn on the switch and push the controller buttons to test the pods.

Adjusting Pod Count

By default, the Switch Box is set to control 4 pods on each zone. If you are connecting more, you must synchronize the Switch Box following the steps below. The Switch Box has the ability to adjust the strobe patterns to best suit the amount of pods utilized on any given vehicle. To adjust the pod count, hold the SOLID and STROBE buttons down at the same time for 3 seconds until the first pod on each output zone lights up solid. The red LED indicators above the SOLID and STROBE buttons will also breath during synchronization. Press the RIGHT CHASE button to increase the pod count or the LEFT CHASE button to decrease the pod count. Once all of the pods are illuminated solid, press and hold the SOLID and STROBE buttons again until the pods flash 3 times. This means that synchronization is complete and the kit is ready for install.

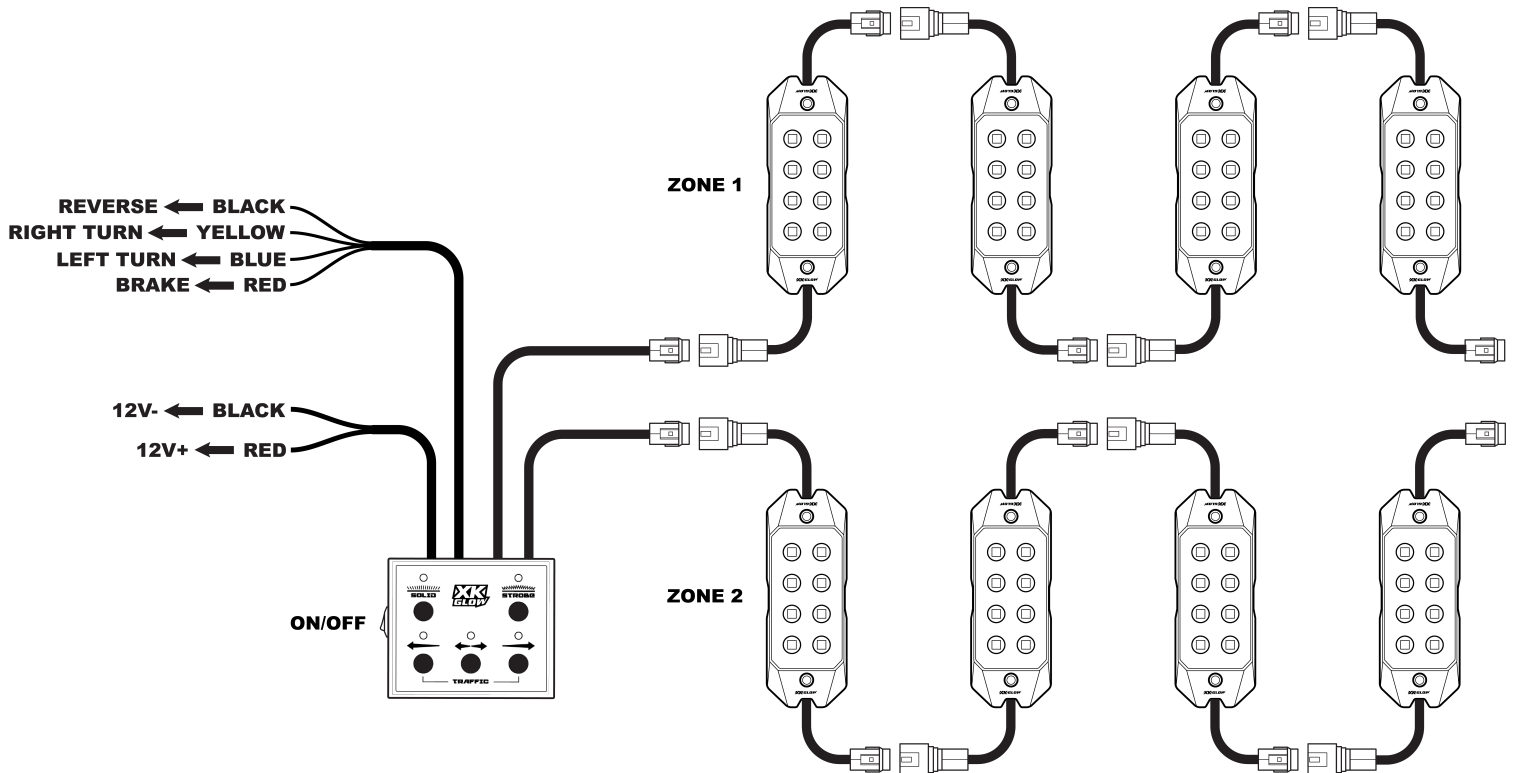

Pod Orientation

The strobe system features directional chasing functions controlled via the included Switch Panel. These functions include a Right Chase mode, Left Chase mode, Center Chase mode, and optional left or right turn signals. In order for these functions to work properly, the pods must be wired in the correct orientation. Each output zone from the Switch Panel must begin on the driver side of the vehicle. If not, the chasing patterns will be opposite of what is reflected on the Switch Panel buttons. See diagram below.

DAISY CHAINS MUST BEGIN ON DRIVER SIDE

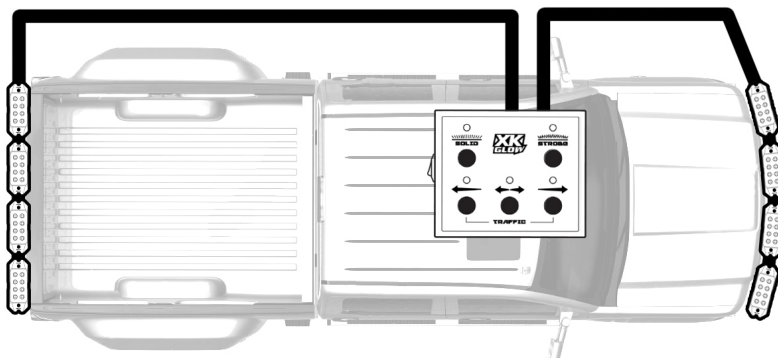

Wiring Options

Option A. Surface Mount Wiring: The pod was designed to allow for easy surface mounting. Simply cut off two of the tabs on the rubber grommet to make room for the wiring to enter/exit and ensure the wiring follows the channels on the back of the pod when mounting. Failure to follow the wiring channels may result in pinched/broken wiring when screwing the pod into place. Options below.



Select two of the four tabs on the rubber grommet for the wiring to feed through. These will be for the input and output wires. Choose what best fits selected pod in its desired mounting location and using a pair of scissors or a razor blade, carefully cut off the two tabs. Leave the remaining two tabs in place to prevent dirt/grime buildup under the pod.

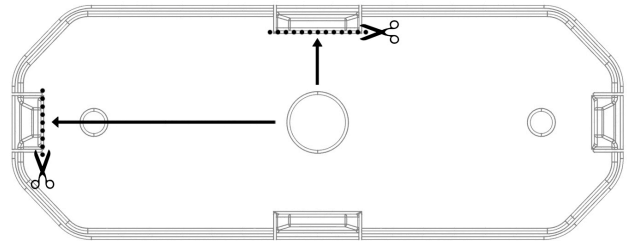

Option B. Through Hole Wiring: If you can access the rear of the panel you are mounting to, you can utilize the through-hole wiring method. Simply drill a $\frac{3}{4}$ " hole in your desired mounting location and feed the wiring through to the rear of the panel. This method can be seen to the right.

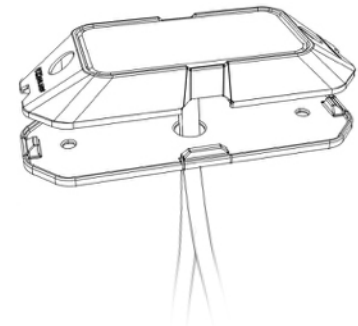

1. **Optional- Mark and drill for Through-Hole Wiring:** If utilizing the through-hole wiring method, mark and drill a $\frac{3}{4}$ " hole in the center of your desired mounting location.
2. **Install Pods:** Place the rubber grommet into place. Feed the wiring through the channels on the rear of the pod housing or through the drilled hole and fit the pod into place. Ensure that there are no pinched wires on the back side of the housing. Using self-tapping screws, secure the pod into place. If preferred, you can use nuts and bolts instead of the self-tapping screws (not included)

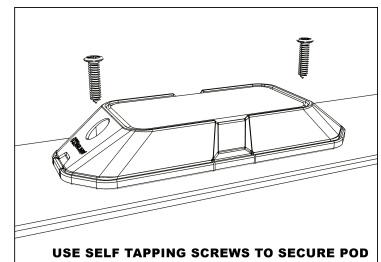
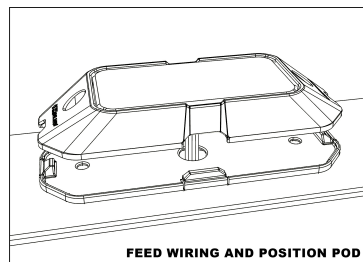
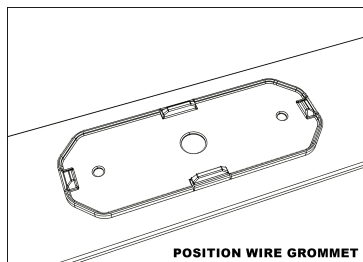
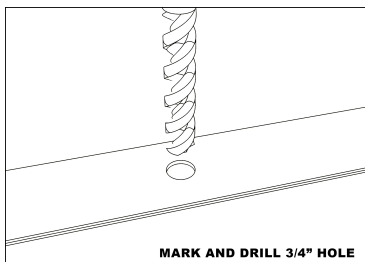

3. **Route wiring:** Mount the Switch Panel in a convenient location. Connect the RED wire to the POSITIVE pole of 12V DC battery or a 12V source inside the cab. Connect the BLACK wire to the NEGATIVE pole or to a chassis ground bolt. Utilizing the included extension wires, route the output wires to the first pods on the driver side of the vehicle. Daisy chain the remaining pods together from driver side to passenger side.
4. **Optional- Tap signal wires:** The Switch Panel has 4 sensor wires exiting it; black, yellow, blue, and red. These signal wires automatically trigger a driving function when they receive 12V. The YELLOW wire activates the right turn mode and BLUE activates the left turn mode. Tap these wires into the positive turn signal wire for each side to utilize this feature. If you are only

using strobe lights on the rear of the vehicle, you can take advantage of the brake and reverse modes. The BLACK wire activates reverse and the RED wire activates the brake mode. If desired, tap these into the corresponding wire on your vehicle.

BLACK – REVERSE
YELLOW – RIGHT TURN
BLUE – LEFT TURN
RED – BRAKE

Switch Box Functions

The Switch Box has 5 buttons to control the strobe pods. These buttons are SOLID, STROBE, LEFT CHASE, CENTER CHASE, and RIGHT CHASE. There is a master ON/OFF switch on the side of the Switch Box. Turning the switch to OFF will cut all power from the pods and disable any of the signal wire functions (ie right turn signal). Holding any single button down will turn all pods off.

SOLID – pressing this button will turn all pods solid on.

STROBE – pressing strobe will activate strobe mode. Press repeatedly to cycle through different strobe patterns.

LEFT CHASE – press left chase to activate the left chasing mode. This will make the pods chase from the passenger side to the driver side of the vehicle.

CENTER CHASE – press center chase to activate the center chase mode. The pods will illuminate from the center and cycle outwards. Please note that if the Switch Box has been synchronized for 3 or less pods, the center chase mode will be disabled.

RIGHT CHASE – press right chase to activate the left chasing mode. This will make the pods chase from the driver side to the passenger side of the vehicle.