



# SUPERLIFT®

## S U S P E N S I O N

Superlift 4" lift system for  
1984-2001 JEEP CHEROKEE XJ with coil spring suspension

### INSTALLATION INSTRUCTIONS

#### INTRODUCTION

Installation requires a professional mechanic. Prior to beginning, inspect the vehicles steering, driveline, and brake systems, paying close attention to the track bar, suspension link arms and bushings, anti-sway bars and bushings, tie rod ends, pitman arm, ball joints and wheel bearings. Also check the steering sector-to-frame and all suspension-to-frame attaching points for stress cracks. The overall vehicle must be in excellent working condition; repair or replace all worn parts.

**Read instructions several times before starting. Be sure you have all needed parts and know where they install. Read each step completely as you go.**

#### NOTES:

**If the optional Rockrunner System is being installed, refer to those instructions before proceeding.**

- **Prior to beginning the installation, check all parts and hardware in the box with the parts list below. If you find a packaging error, contact Superlift directly. Do not contact the dealer where the system was originally purchased. You will need the control number from each box when calling; this number is located at the bottom of the part number label and to the right of the bar code.**
- Front-end realignment is necessary.
- A factory service manual should be on hand for reference. The manual will contain fastener torque specs, assembly techniques, and special tool requirements that are unique to this particular year and model vehicle.
- Do not add or fabricate any components to gain additional suspension height.
- Any welding must be performed by a professional certified welder.
- After drilling, file smooth any burrs and sharp edges or stress cracks may develop.
- Paint or undercoat all exposed metal surfaces.
- Prior to attaching components, be sure mating surfaces are free of grease, grit, oil, undercoating, etc.
- A torque specification in foot pounds is shown in parenthesis "( )" after each fastener.
- Use the check-off box "☐" found at each step to help keep your place. Two "☐☐" denotes that one check-off box is for the driver side and one is for the passenger side.
- An arrow on diagrams indicates which direction is towards "front of vehicle".

- Retain all factory hardware for reuse, unless otherwise specified.

**PARTS LIST**

The part number is stamped into each part or printed on an adhesive label. Identify each part and place the appropriate mounting hardware with it.

<b>PART NO</b>	<b>DESCRIPTION</b> (Qty.- if more than one)	<b>ATTACHING HARDWARE</b> (Qty.)
01-550.....	(2) front coil spring	
01-522.....	(2) rear leaf spring	
018.....	(2) 1.5" lift block	
10184.....	(4) U-bolt .....	(8) 1/2" extra thick flat washer (8) 1/2" fine-thread nyloc nut
55-03-5073.....	lower trailing link, front..... driver side	(2) bushing half (1) sleeve (1) zerk fitting
55-04-5073.....	lower trailing link, front..... passenger side	(2) bushing half (1) sleeve (1) zerk fitting
55-12-5140.....	(2) upper trailing link, front	
55-02-5140.....	(2) transfer case drop bracket, .... 1994-2003 models	(4) 10mm x 60mm bolt (4) 10mm flat washer (4) 10mm lock washer
<b>OR</b>		
55-14-5140.....	(2) transfer case drop bracket, .... 1984-1993 models	(4) 10mm x 50mm bolt (4) 10mm flat washer (4) 10mm lock washer
55-04-5140.....	transfer case shifter plate .....	(2) 5/16" x 1" (2) 5/16" SAE washer (2) 5/16" nyloc nut (2) 6mm x 20mm bolt
55-01-5067.....	(2) anti-sway bar bracket, front....	(2) 3/8" x 1-1/2" bolt (2) 3/8" nyloc nut (2) 5/8" OD x 7/16" sleeve
55-09-5064.....	(2) anti-sway bar link, front .....	(2) 7/16" x 2-3/4" bolt (2) 7/16" Nyloc nut (4) poly bushing (4) sleeve
66-20-5100.....	(2) lower compression travel .....	(2) 5/16" x 1-3/4" self-tapping bolt stop spacer
1106.....	pitman arm .....	cotter pin, 1/8" x 2"
55-08-5070 .....	adjustable track bar, front .....	(2) bushing half

- (1) sleeve
- (1) extra-thick washer
- (1) 1/2" X 3-1/2" bolt
- (1) nyloc nut
- (1) spacer
- (1) tapered spacer
- (1) heim joint end
- (1) 1/2" x 3-1/2" bolt w/ hole
- (1) 1/2" castle nut
- (1) 1/2" SAE washer
- (1) cotter pin
- (1) 3/4" jam nut
- 55-13-5140 ..... brake line bracket, rear ..... (1) 1/4" x 3/4" bolt  
(1) 1/4" nyloc nut
- 85121..... (2) front shock absorber ..... (2) shock hardware pack
- 85306..... (2) rear shock absorber ..... (2) shock hardware pack
- 86010..... (4) yellow shock absorber boot\* ... (4) shock boot cable tie
- \*(Note: Shock boot, if desired, purchased separately.)**
- 0034..... Superlift badge ..... alcohol wipe pad

**FRONT DISASSEMBLY**

- 1) PREPARE VEHICLE...**
  - Place vehicle in neutral. Raise front of vehicle with a jack, and secure a jack stand behind the lower link arms, beneath each frame rail. Ease the frame down onto the stands. Support the outboard end of the driver and passenger side axle tube with a floor jack; the frame is to remain on the stands.
- 2) TRACK BAR...**
  - Remove the bolts connecting the track bar to the axle and frame and remove the bar from the vehicle. Save all hardware for re-use.
- 3) DRAG LINK and PITMAN ARM...**
  - Remove the cotter pin and nut that connects the drag link-to pitman arm. Use a puller tool to detach the link from the arm.
  - Remove the nut and washer from the steering gear shaft, then use a puller tool to remove the pitman arm from the shaft.
- 4) SHOCK ABSORBERS...**
  - Remove and discard the factory shocks.
- 5) ANTI-SWAY BAR LINKS...**
  - On each side, disconnect the sway bar link from the axle bracket and the bar body.

**NOTE: Steps 6 through 11 should be performed one side at a time. Start on the driver side.**

### 6) LOWER LINK ARMS...

- Verify that the jack is supporting the front axle. Remove the bolt attaching the lower link at the axle, followed by the attachment point at the frame, and remove the link from the vehicle. Save all hardware for reuse.

### 7) COIL SPRINGS...

- Lower the jack/axle assembly until the coil spring is free from its upper seats. A retainer clip must be removed at the base of the driver side coil. Remove the coil from the vehicle.

## FRONT ASSEMBLY

### 8) COMPRESSION TRAVEL STOPS: (qty. 2) #66-20-5140...

- Drill out the existing indent in the center of the lower spring seat to 17/64"
- Position the lower compression stop spacer (#66-20-5100) on the spring seat and secure using the supplied 5/16" x 1-3/4" self-tapping bolt (24).

### 9) COIL SPRINGS #550...

- Lower the axle far enough to facilitate installing the coil spring. Use caution to prevent over-extending brake lines, vent hoses, etc.
- Install the coil. Position the coil in the tower first, then slide it into place on the axle seat.
- Reattach the retaining clip at the bottom of the driver side coil.

### 10) LOWER LINKS...

- Lubricate and install the supplied bushings and sleeves in the lower links (#55-03-5073 driver side and #55-04-5073 passenger side).

- [DIAGRAM 2] Install the 5073 lower links using the factory hardware. Note the eye offset: be sure to install each link as shown using the factory hardware. Note that both bolts should be installed from the outside. Snug, but do not tighten at this time.

### 11) UPPER LINKS...

- Remove the bolt securing the upper trailing link arm to the axle, followed by the bolt at the frame, and remove the factory link.
- Install the #55-12-5140 using the factory hardware. Snug, but do not tighten at this time.

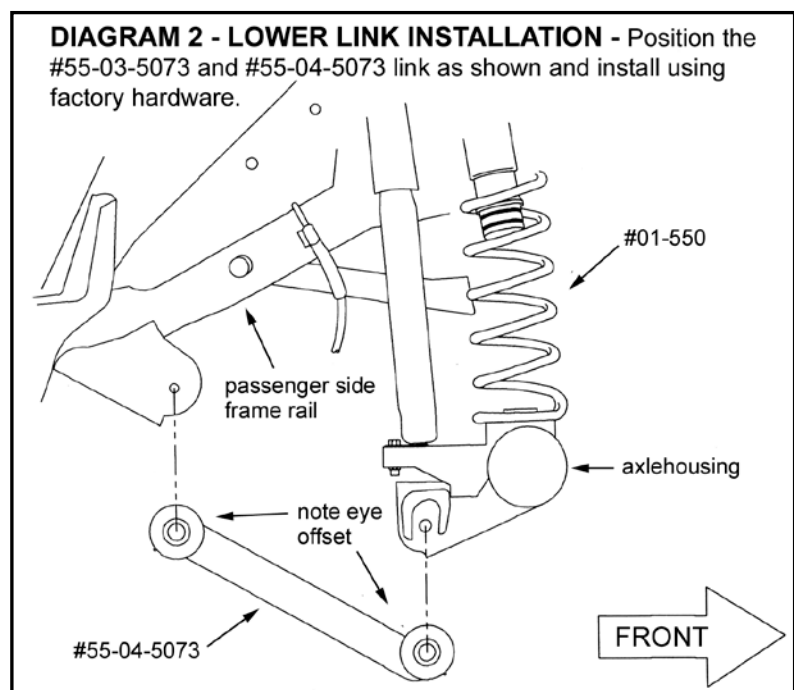

- Repeat steps 6 through 11 on the passenger side.

## 12) SUPERLIFT SHOCK ABSORBERS...

On each side:

- Install shock boot and decal.
- With the lower half of the stem hardware in place, insert the top end of the shock through the hole in the factory shock tower. Install the other half of the hardware and tighten only until the bushings start to swell slightly. Install jam nut.
- Attach the lower end of the shock to the axle using the factory hardware (21).

## 13) TRACK BAR...

**NOTE:** In some cases it may be easier to install the track bar once the vehicle is back on the ground with the suspension supporting the vehicle's weight. However, moving the vehicle without the track bar, even a very short distance, is not recommended .

- Lubricate and install the supplied bushings and sleeves in the lower end of the track bar (55-11-5100). Note that the supplied thick washer should be positioned between the bushing halves inside the eye of the bar.
- Thread the heim joint with the supplied jam nut in the upper end of the track bar. Set the length of the track bar at 32-1/2" measured from the center of each eye. This will provide a baseline for adjustment.
- Test-fit the supplied 1/2" bolt in the lower track bar mount on the axle. If necessary, enlarge the mounting hole using a 1/2" drill bit.
- [DIAGRAM 3] Slide the bushing end of the track bar into the axle bracket and attach using the supplied 1/2" x 3-1/2" bolt and nyloc nut (75).

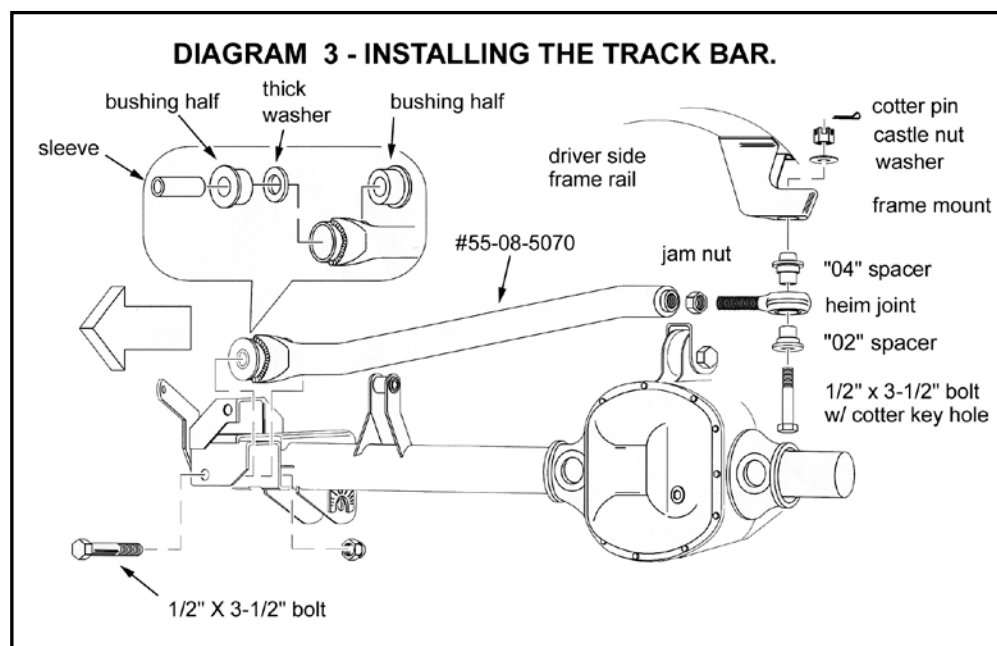

- Insert the tapered spacer (55-04-5070) in the bottom of the frame mount, then attach the heim end of the track bar followed by the standard spacer (55-02-5070) as shown in Diagram 6. Connect using the 1/2" x 3-1/2" bolt with cotter pin hole, washer, and castle nut. Do not fully tighten at this time.

**NOTE:** Final adjustment of the track bar will be done after installation is complete. Save the supplied cotter key for later use.

#### 14) SUPERLIFT PITMAN ARM #1106...

- Align and install the pitman arm on the steering gear shaft. Install the stock washer and nut then tighten (185).
- Connect the drag link to the pitman, tighten nut (60), and install new cotter pin. If the castellations and the cotter pin do not align, tighten (do not loosen) the nut until they align.

#### 15) ANTI-SWAY BAR LINKS:

(qty. 2) #55-09-5064 FOR FRONT ANTI-SWAY BAR LINK...

**Note:** If optional Superlift Quick Disconnect links are being used, install now per separate instructions.

- Attach a #55-01-5067 bracket to each end of the sway bar body using a 3/8" x 1-1/2" bolt, 5/8" OD x 7/16" long sleeve and nyloc nut (23). The sleeve should be positioned inside the hole in the sway bar body. Insert the bolt facing up, and be sure the bracket legs are facing downward.
- Install the supplied bushings and sleeves into the eyes of each #55-09-5064 anti-sway bar link. Note that the smaller ID sleeve installs on the upper end of each link.
- Position the upper end of each link into the #55-01-5067 bracket and secure using the supplied 7/16" x 2-3/4" bolt (38). Note that the bolts should be installed from the outside.
- Slide the lower end of each link into the stock brackets on the axle and secure using the stock hardware. Tighten to factory specifications.

#### 16) TIRES / WHEELS...

**CAUTION:** Before installing each wheel, be sure to remove any built-up corrosion on the wheel mounting surfaces. Ensure wheels are installed with good metal-to-metal contact. Improper installation could cause loosening of the wheel nuts. Never use oil or grease on lug studs or nuts.

- [DIAGRAM 4] All wheel nuts should be tightened just snug, then gradually tightened in sequence to the proper torque specification (80 to 110).

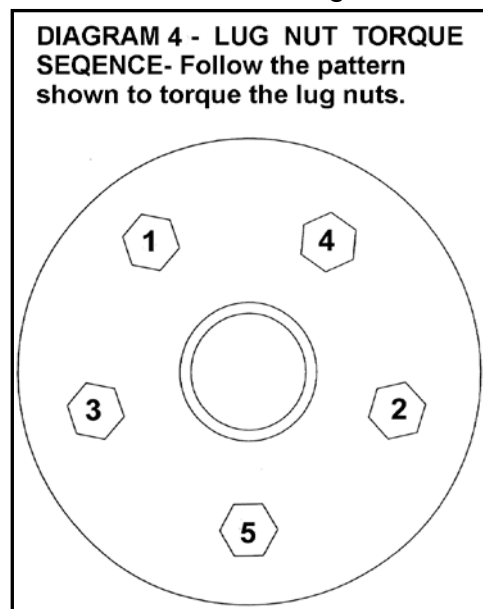

- ❑ With front of vehicle still on stands, and suspension “hanging” at full extension travel, turn steering lock-to-lock while checking components for proper operation and clearances.
- ❑ Remove jack stands and lower vehicle to floor.

### 17) TIGHTEN the SUSPENSION COMPONENTS...

The suspension must be supporting the vehicle’s weight when these components are torqued:

- ❑ Lower link arm-to-axle cam bolt nut (85). Before tightening, match-up the alignment marks on the cams and axle brackets that were made in Step 6.
- ❑ Lower link arm-to-frame nut (130). Track bar-to-axle bolt (55).

### 18) TORQUE SHAFT BRACKET #55-04-5140...

The torque shaft bracket is part of the transfer case shifter assembly. This step prevents shifter bind after the case is lowered.

- ❑ [DIAGRAM 5] From under the vehicle, locate the torque shaft bracket. It is attached to the inside of the transmission tunnel and acts as a pivot for the transfer case shift lever. Remove the two bolts that attach the swivel plate-to-bracket. Also remove the swivel plate gasket.
- ❑ Attach the swivel plate and gasket to the Superlift torque shaft bracket (#55-04-5140) using the factory bolts and nuts (18).
- ❑ Insert the torque shaft through the swivel plate, then attach the “06” bracket to the factory torque shaft bracket as shown using the supplied 6mm x 20mm allen head bolts and nuts (18).

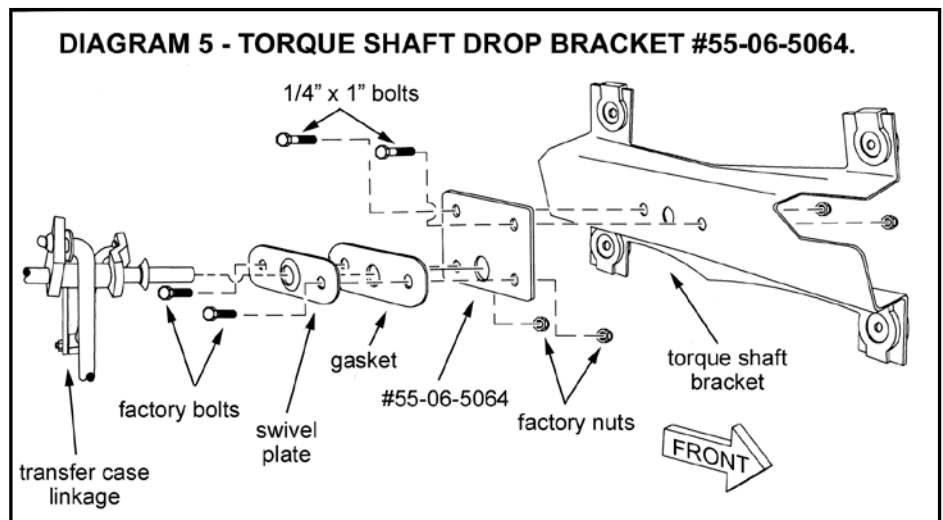

### 19) LOWERING the TRANSFER CASE...

- ❑ Position a jack beneath the driver side of the transmission crossmember, just inboard of the crossmember-to-frame mounting bolts. Load the jack so that it will support the crossmember’s weight when the two bolts are removed. After removing the driver’s side bolts, loosen (do not remove) the passenger’s side crossmember-to-frame bolts.

#### For 1994-2003 models:

- ❑ Lower the jack just enough to install one of the #55-02-5140 transfer case drop brackets and insert the supplied 10mm x 60mm bolts with flat and lock washers. Leave the bolts loose so the other side can be installed.
- ❑ Relocate the jack to the passenger side and repeat the installation procedure for the other “02” drop bracket.

- Tighten all four crossmember bolts (35).

**For 1984-1993 models:**

- Lower the jack just enough to install one of the #55-14-5140 transfer case drop brackets and insert the supplied 10mm x 50mm bolts with flat and lock washers. Leave the bolts loose so the other side can be installed.
- Relocate the jack to the passenger side and repeat the installation procedure for the other "14" drop bracket.
- Tighten all four crossmember bolts (35).

## REAR PROCEDURE

### 20) PREPARE VEHICLE...

- Raise rear of vehicle with a jack positioned at outboard ends and secure a jack stand beneath each frame rail, in front of the forward spring hangers for the rear springs. Ease the frame down onto the stands, but leave a slight load on the jack. Chock front tires. Remove rear tires.

### 21) SHOCK ABSORBERS...

- Disconnect and discard the factory shocks.

### 22) REAR BRAKE LINE RELOCATION...

- Remove the clip securing the rear brake hose junction at the frame. Save the clip for re-use. Carefully pull the brake line junction out of the bracket and slide it out of the way.

- [Diagram 6] Position the #55-13-5140 extension bracket against the factory bracket as shown and clamp it in place. Using the bracket as a template, drill a 1/4" hole in the factory bracket. Install the supplied 1/4" x 3/4" bolt and nyloc nut and tighten (76 in-lb).

- Carefully re-form the metal brake line to reach to lower portion of the "13 extension bracket and slide the junction into place. Reinstall the factory retaining clip.

**WARNING:** Use extreme caution to avoid kinking or otherwise damaging the metal line.

### 23) REAR SPRINGS...

- Position a jack under the rear axle so that it supports, but does not raise, the axle.

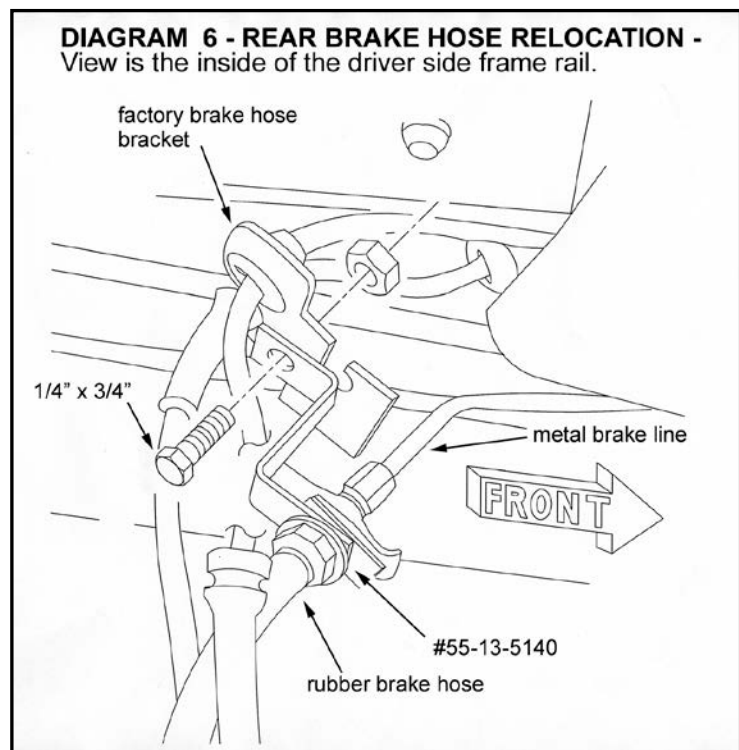



- Remove and discard the U-bolts securing the axle to the leaf springs. Save the U-bolt top plates for re-use.
- Unbolt the front spring eye, followed by the shackle bolt at the frame, and remove the spring from the vehicle.
- Remove the shackle from the factory springs and install it on the Superlift spring opposite the eye marked "front." Make sure the orientation of the shackle and bolt is the same as it was on the original spring.
- Carefully lower the axle enough to facilitate the installation of the new springs. Position the eye of the Superlift spring marked "front" in the front spring hanger and secure using the factory hardware. Line up the shackle with the rear spring mount and secure using the factory hardware. Snug, but do not tighten at this time.

**NOTE:** The spring perches are prone to collapse or warp where the leaf springs or blocks seat on the axle, especially towards the ends. Without a perfectly flat mounting surface, the block may fail and "roll" out off of the perches. Very bad things happen when this occurs. If the perches are not flat, fix them by welding on a piece of ¼" plate (or something similar) or replace the perches completely.

- Make sure the top of the spring perches and the bottom of the springs are clean and free of any debris. Position the Superlift blocks in between the leaf springs and the spring perches and be sure the locating pins in both the lift block and the leaf spring are seated properly.
- Install the supplied U-bolts and plates, then torque the bolts in an "X" pattern (57).

#### 24) SUPERLIFT SHOCKS...

- Install shock boot and decal.
- Position shock and tighten the two upper bolts (23) and the single lower bolt (74).

#### 25) TIRES / WHEELS...

**CAUTION:** Before installing each wheel, be sure to remove any built-up corrosion on the wheel mounting surfaces. Ensure wheels are installed with good metal-to-metal contact. Improper installation could cause loosening of the wheel nuts. Never use oil or grease on lug studs or nuts.

- [DIAGRAM 4] All wheel nuts should be tightened just snug, then gradually tightened in sequence to the proper torque specification (80 to 110).
- With front of vehicle still on stands, and suspension "hanging" at full extension travel, check all components for proper operation and clearances.

Remove jack stands and lower vehicle to floor.

**27) TRACK BAR ADJUSTMENT...**

- Verify that the tires are still pointed straight ahead. Position a plumb bob or similar tool against the inside edge of the frame. Measure the distance between the line of the plumb bob and the inside edge of the wheel. Record this measurement, then repeat the procedure on the other side.
- Compare the two measurements recorded in the previous step; the goal is to make them equal. If the driver side measurement is greater than the passenger side, the track bar needs to be lengthened. If the passenger side measurement is greater than the driver side, the track bar needs to be shortened. In most cases, the track bar on a lifted vehicle needs to be longer than stock.
- Remove the upper end of the track bar from the vehicle and make the appropriate adjustments. Tighten the jam nut firmly, then reattach the bar to the frame and torque (57).
- Wiggle the front tires back and forth several times to fully seat the track bar. Repeat the measuring procedure to verify the adjustments made were correct.

**NOTE:** The maximum amount of adjustment is no more than 3/8" of exposed heim joint threads as measured from the end of the track bar.

- Install the supplied cotter pin in the castle nut on the upper end of the track bar.

**28) TIGHTEN the SUSPENSION COMPONENTS...**

The suspension must be supporting the vehicle's weight when these components are torqued:

- Track bar, both ends (75)
- Lower link arm, both ends (130)
- Upper link arm, frame end (55)
- Upper link arm, axle end (55)
- rear spring, front eye (103)
- rear spring, shackle end (103)

**29) HEADLIGHTS...**

- Readjust headlights to factory setting.

**30) FINAL OVERALL INSPECTION and TORQUE CHECK...**

- Perform a front-to-rear inspection. With the suspension supporting vehicle weight, cycle steering lock-to-lock and inspect steering, suspension, driveline, and brake systems for proper operation, tightness, and adequate clearances. Re-torque all fasteners.

**31) TRANSMISSION SHIFTER MODIFICATION...**

This step is only necessary if the vehicle exhibits problems shifting after the lift installation is complete.

- Test drive the vehicle and shift through all gears. If it is difficult to shift into (or the transmission jumps out of) Second, Fourth, or Reverse, the shifter is likely hitting the edge of the transmission tunnel due to the transfer case drop and will need to be modified slightly.

- Set the parking brake on the vehicle and put the transmission in neutral. Remove the shift knob and upper shifter boot. Shift the transfer case lever into neutral and remove the console, lower shift boot, and dust boot.
- Shift the transmission and note where it is making contact with the floorboard. Trim the floorboard as necessary until there is adequate clearance between the shifter and the floorboard.
- Reassemble the shifter and install it by reversing the steps followed for disassembly. Note that it might also be necessary to make some slight alterations to the console and shifter boot retainer as well.

### **32) SAFETY DECAL...**

- Install "Warning to Driver" decal. Refer to the "NOTICE TO DEALER AND VEHICLE OWNER" section below.

### **33) ALIGNMENT...**

- Realign vehicle to factory specifications.

#### **IMPORTANT PRODUCT USE INFORMATION**

As a general rule, the taller a vehicle is, the easier it will roll over. Offset, as much as possible, what is lost in roll over resistance by increasing tire track width. In other words, go "wide" as you go "tall". Many sportsmen remove their mud tires after winter / hunting season and install ones more appropriate for street driving; always use as wide a tire and wheel combination as possible to enhance vehicle stability.

We strongly recommend, because of roll over possibility, that the vehicle be equipped with a functional roll bar and cage system. Seat belts and shoulder harnesses should be worn at all times. Avoid situations where a side rollover may occur.

Generally, braking performances and capabilities are decreased when significantly larger / heavier tires and wheels are used. Take this into consideration while driving.

Do not add, alter, or fabricate any factory or aftermarket parts to increase vehicle height over the intended height of the Superlift product purchased. Mixing component brands is not recommended.

Most states have some type of law limiting vehicle height. The amount of lift allowed, and how the lift may be achieved, varies greatly. Several states offer exemptions for farm or commercially registered vehicles. It is the owner's responsibility to check state and local laws to ensure that their vehicle will be in compliance.

Superlift makes no claims regarding lifting devices and excludes any and all implied claims. Superlift will not be responsible for any altered product or any improper installation or use of our products.

We will be happy to answer any questions concerning the design, function, and correct use of our products.

#### **IMPORTANT MAINTENANCE INFORMATION**

It is the ultimate buyer's responsibility to have all bolts / nuts checked for tightness after the first 100 miles and then every 1000 miles. The steering, suspension and driveline systems, along with wheel alignment should be inspected by a qualified professional mechanic at least every 3000 miles.

#### **NOTICE TO DEALER AND VEHICLE OWNER**

Any vehicle equipped with a Superlift lifting device must have the enclosed "Warning to Driver" decal installed on the inside of the windshield or on the vehicle's dash, within driver's view. The "Warning to Driver" decal is to act as a constant safety reminder for whoever may be operating the vehicle. The WARRANTY IS VOID unless this decal is in place. INSTALLING DEALER... It is your responsibility to install warning decal and forward these installation instructions to the vehicle owner for review of warnings, product use and maintenance information. Replacement warning decals are available free upon request. These instructions are to be kept with the vehicle registration papers and owners manual for the service life of the vehicle.

**SUPERLIFT LIMITED LIFETIME WARRANTY**

Suspension products bearing the Superlift (LKI Ent.) name are warranted for as long as the original purchaser owns the vehicle that the LKI product was originally installed on. This warranty is non-transferable. Warranty covers only the product, no labor, time loss, or freight incurred. Any product that has been abused, altered, incorrectly installed, or used in competition is not covered. Product finish, spring bushings, Polyurethane products, and normal wear is not covered. The LKI product is subject to replacement or repair. No other warranties are expressed or implied. An authorized Superlift dealer must inspect the part in question and confirm that the "Warning to Driver" decal is properly displayed. A copy of the sales invoice is required for warranty consideration.

**SUPERLIFT SUSPENSION SYSTEMS**

300 Huey Lenard Loop Rd.  
West Monroe, Louisiana 71292  
Phone: (318) 397-3000  
Sales / Tech: 1-800-551-4955  
FAX: (318) 397-3040  
Web Site: [www.superlift.com](http://www.superlift.com)