

INSTALLATION INSTRUCTIONS



98-1154

Camaro GEN6 Hydraulic Release Bearing

This hydraulic release bearing assembly is self-adjusting in that the bearing stays close to the clutch spring at all times, even though the spring changes position with clutch wear. There is no extra return spring that pulls the piston back all the way to the bottomed position. This provides consistent clutch pedal feel regardless of clutch wear.



INSTALLATION AND ADJUSTMENT

This unit has been pre-adjusted at the factory to nominal release bearing clearance when used with a Tilton ST-246 Twin Disc Clutch Kit. For all other clutches, the unit will most likely need to be adjusted to achieve the recommend .125" - .175" initial bearing clearance. However, the clearance needs to be confirmed with any clutch that is used. There are many parts in the system, and each has a manufacturing tolerance, so you must measure the clearance before installing the transmission. **FAILURE TO SET THE CORRECT BEARING CLEARANCE CAN CAUSE RELEASE BEARING, CLUTCH AND ENGINE DAMAGE!**

1. Remove the factory release bearing assembly, saving the two mounting screws (these will be reused to install the Tilton unit).
2. Using the palms of both hands on the bearing, compress the bearing and piston into the hydraulic base to ensure the unit is fully seated. It is critical that all clearance measurements be taken in this position.
3. Install the unit onto the transmission in the orientation shown in **Diagram 1** (the anti-rotation screw should be straight down):

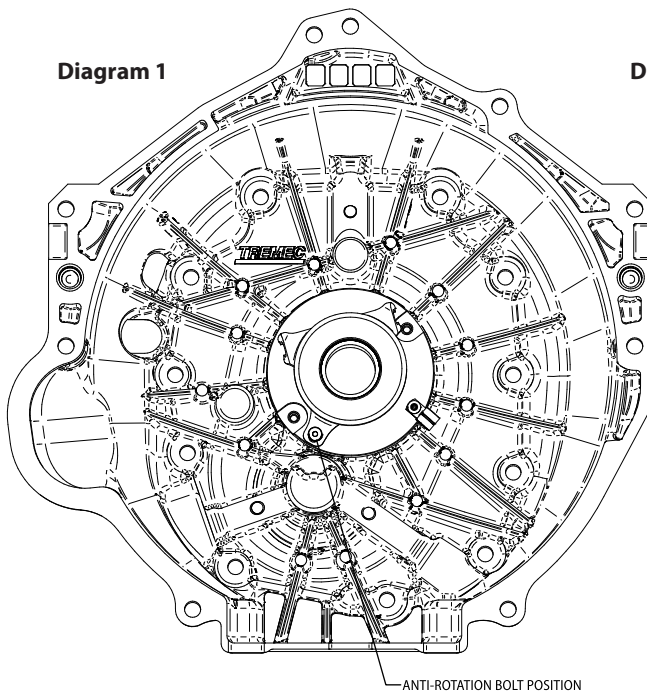
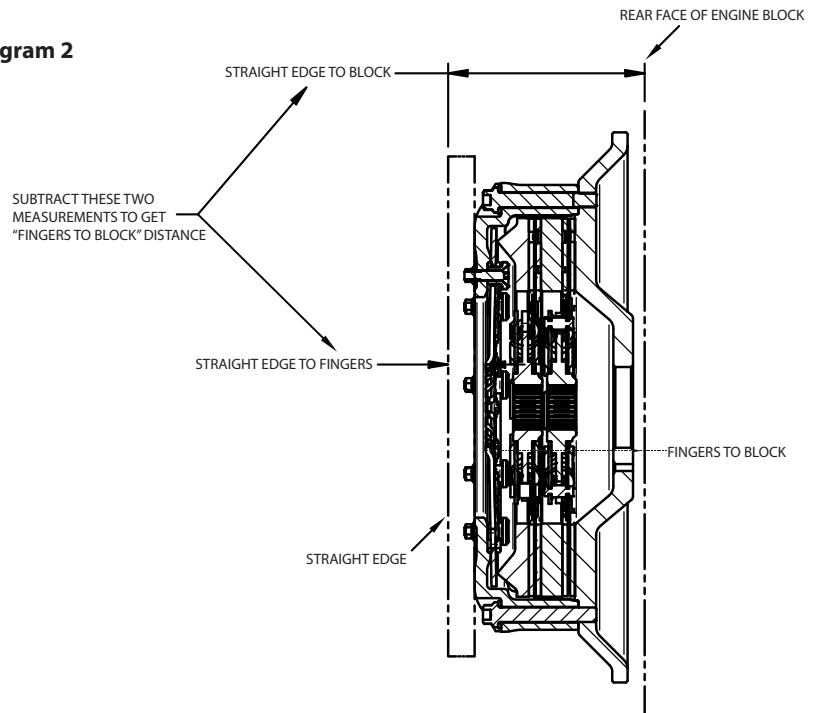
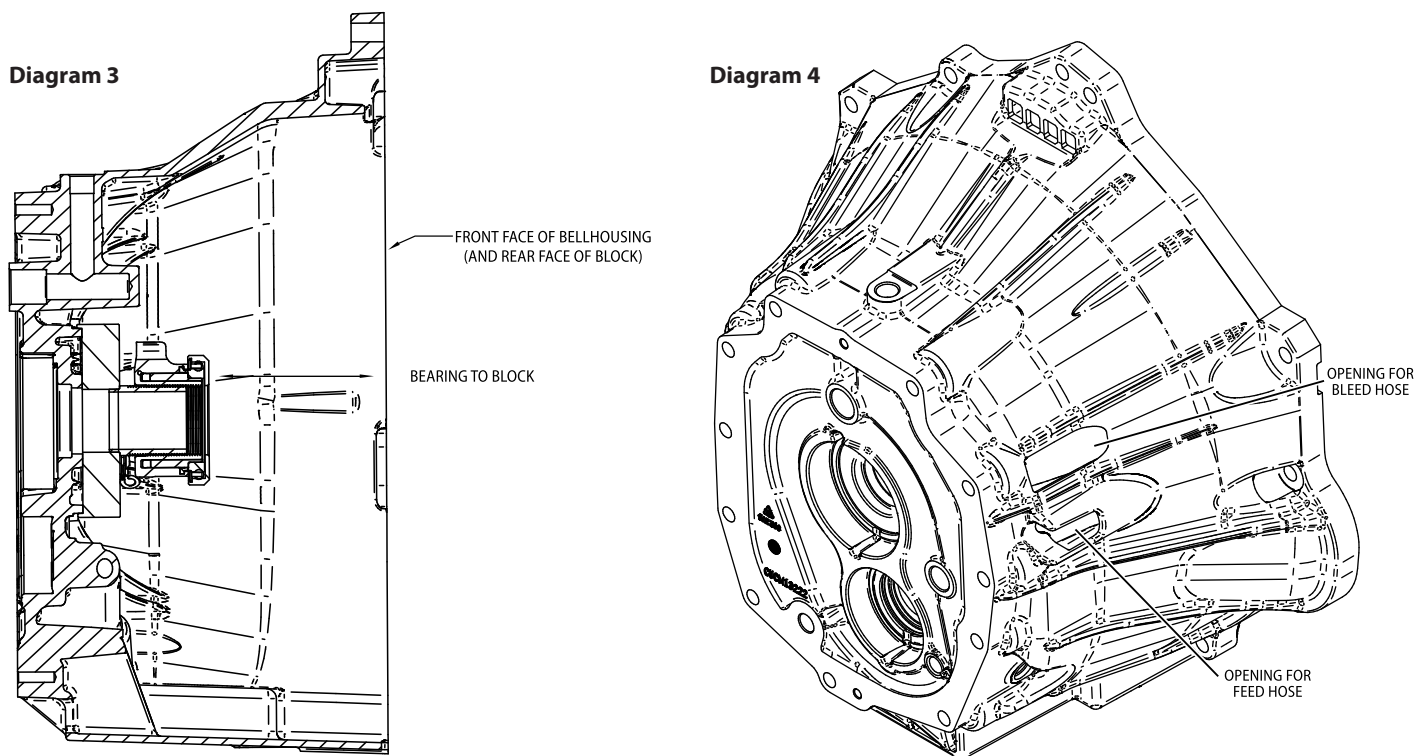

Diagram 2



4. Install the flywheel and clutch onto the engine. Tighten all components in place following the clutch installation instructions.
5. Referring to **Diagram 2**, you must determine the distance from the back of the engine block to the top of the fingers of the clutch. This will take two measurements to determine. Measurement 1: Put a long straight edge along the top of the clutch cover and using dial calipers (not a ruler), measure the distance to the fingers. Measurement 2: With the straight edge in the same position, measure the distance to the block (at bellhousing mounting face). Subtract the two measurements to determine height from block to fingers.
6. Referring to **Diagram 3**, using the same straight edge from Step 5, measure the depth from the block face of the bellhousing to the face of the release bearing. Do not forget to subtract out the thickness of the straight edge. Subtract the distance in Step 5 from the depth in Step 6. This is your bearing clearance. It must be between .125" and .175". If not, remove the anti-rotation screw and adjust the hydraulic unit in or out to achieve the needed height. You may need to remove the entire unit and rotate the position of the base and hydraulic lines to achieve the same orientation as shown in Step 3.



7. Referring to **Diagram 4**, feed both hoses through the holes in the bellhousing. Zip tie the bleed hose to the feed hose and ensure that both are secured away from the rotating clutch and flywheel assembly.
8. Reinstall the rest of the driveline.
9. Connect the factory clutch line to the feed hose using the provided adapter fitting. Pull the U-clip out of the adapter fitting, insert the factory fitting into the adapter and reinstall the U-clip. When finished, it is acceptable for the factory fitting to move back and forth slightly but it should not pull all the way out.

HYDRAULIC RELEASE BEARING BLEEDING

1. Fill the master cylinder reservoir with DOT 3 or DOT 4 brake fluid as recommended by the vehicle's manufacturer. Do not use DOT 5, silicone-based or high temperature resistant brake fluids designed for more than 550°F as some will cause the seals to swell.
2. Apply light force on the clutch pedal. You want enough force to hold the bearing out against the clutch diaphragm spring, but not enough to compress the clutch diaphragm spring.
3. Open the bleed screw that is attached to the bleed hose on the hydraulic release bearing.
4. Completely stroke the pedal and hold the pedal down.
5. Close the bleed screw that is attached to the bleed hose on the hydraulic release bearing.
6. Let the pedal return to its relaxed position and wait a few seconds. Repeat Steps 2 through 6 until all air is removed from the system. Note: Do not stroke the pedal again before the pedal stop is set.

SETTING THE CLUTCH PEDAL STOP

If you are using the factory master cylinder, you should not need a pedal stop and your installation is complete. If you are using an aftermarket master cylinder with either a larger bore or stroke than the factory master cylinder, you **MUST** use a pedal stop to limit the amount of bearing travel. Failure to do this **WILL** result in clutch, bearing and/or transmission damage!

Follow the step below to adjust the pedal stop:

1. Lift the drive wheels off the ground and support the car on jack stands.
2. With the engine off, put the transmission into 1st gear and have someone attempt to rotate the drive wheels.
3. Depress the clutch pedal slowly until the clutch disengages and the drive wheel can be rotated. Do not push it any further.
4. Note the clutch pedal position at this point. Adjust the pedal stop bolt to allow an additional 1/4" of pedal travel.