

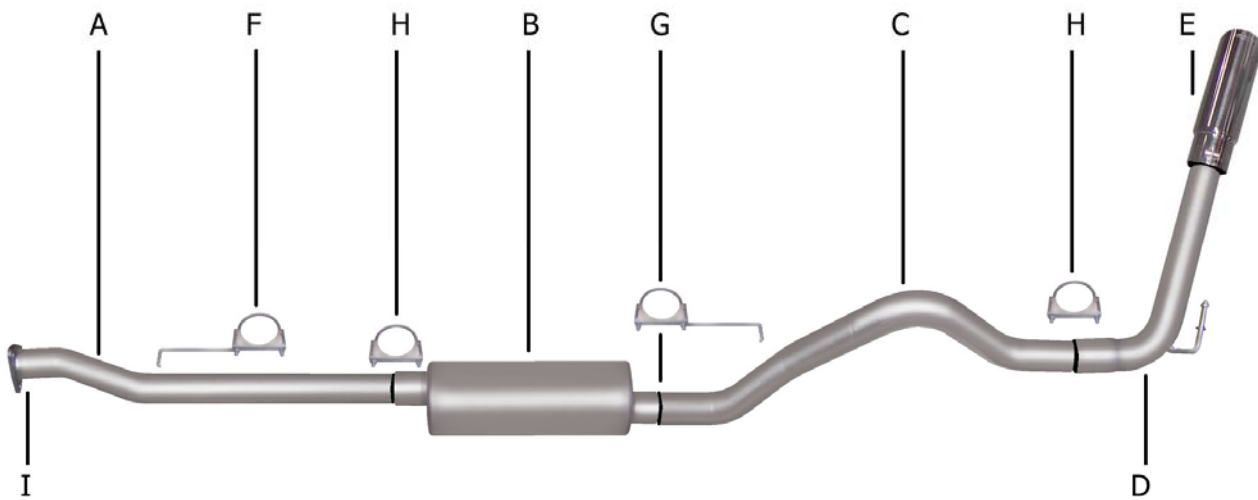

INSTRUCTION MANUAL
CAT-BACK SINGLE EXHAUST
98-03 CHEVY/GMC S10 & EXTREME TRUCK 2.2L, 4CYL 2WD
EXTENDED CAB, SHORT BED
PART # 14428



ITEM	PART #	QUANTITY	DESCRIPTION
A	700144	1	HEADPIPE/WITH FLANGE #GP-104
B	788200	1	SUPERFLOW MUFFLER
C	70039	1	2.5" OVERAXLE TAILPIPE
D	700429	1	2.5" TURNOUT PIPE
E	500361	1	3" STAINLESS STEEL TIP
F	40077	1	FRONT HEADPIPE HANGER
G	40076	1	REAR MUFFLER HANGER
H	5757	2	2-1/2" CLAMP
I	9685	1	GASKET FOR HEADPIPE FLANGE

Z85 SUSPENSION, STOCK REAR SWAY BAR

Thank you for purchasing our GIBSON EXHAUST SYSTEM for your vehicle. If you need further assistance, please do not hesitate to call our Technical Department at (800) 528-3044, Monday through Friday, 8:00 am to 5:00 pm. 0806

EXHAUST INSTALLATION

PART #14428

WHEN INSTALLING THIS EXHAUST SYSTEM MAKE SURE TO USE PROPER SAFETY PRECAUTIONS. USE JACK STANDS WHEN UNDER THE TRUCK, ALONG WITH SAFETY GLASSES. DO NOT WORK WITH HOT PIPES!

SUGGESTED TOOLS

HACKSAW, JACKSTAND, $\frac{1}{2}$ " WRENCH & SOCKET, 14MM SOCKET & WRENCH, 9/16" WRENCH & SOCKET, GASKET SEALER, AND WD-40.

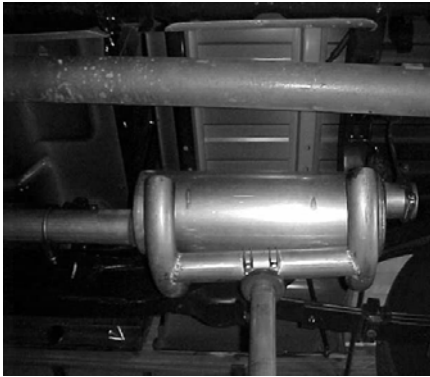

1. Lay out the GIBSON EXHAUST SYSTEM on the floor so it looks like the drawing. Match all part numbers with the manual. Unbolt stock exhaust from behind the catalytic converter. Leave all rubber grommets in place. Use jack stands to support converter. **You will re-use the factory nuts on headpipe flange.**



4. BEFORE INSTALLING OVERAXLE TAILPIPE, THE FACTORY REAR TAILPIPE HANGER MUST BE UNBOLTED AND ROTATED 180 DEGREES. Insert the overaxle tailpipe. #C no less than $1\frac{1}{2}$ " and no more than 2". Slightly lean to the driver side. Slide turnout pipe #D on to the tailpipe. Roll turnout pipe until you have it at the correct angle for your truck. Insert welded hanger into rubber grommet. Clamp down. Using clamp #H



2. Bolt on front headpipe #A re-using factory bolts and gasket #I. Use a RTV gasket sealer for flange connection. (Note Headpipe will lean toward passenger side.) Install hanger #F onto the front headpipe and insert into rubber grommet.

3. Slide muffler #B no less than $1\frac{1}{2}$ " and no more than 2" onto the front headpipe with louvers in muffler facing towards the converter Attach to headpipe with clamp #H. Attach to headpipe with clamp #H. Use a jack stand to support the muffler. Outlet of muffler should be clocked at 12 o'clock. Install rear hanger #G onto muffler. Bolts will face the driverside and insert into rubber grommet. Do not tighten. Inlet of muffler is looking into the louvers.



5. Install stainless steel tip. Clamp down. To clean stainless steel tip use any stainless or aluminum cleaner. When you have everything in place, tighten all bolts and clamp down.

MAKE SURE YOU HAVE A 1" CLEARANCE ON ALL PIPES FROM RUBBER BRAKE LINES, FUEL LINES, SHOCK BOOTS, TIRES, ETC...