

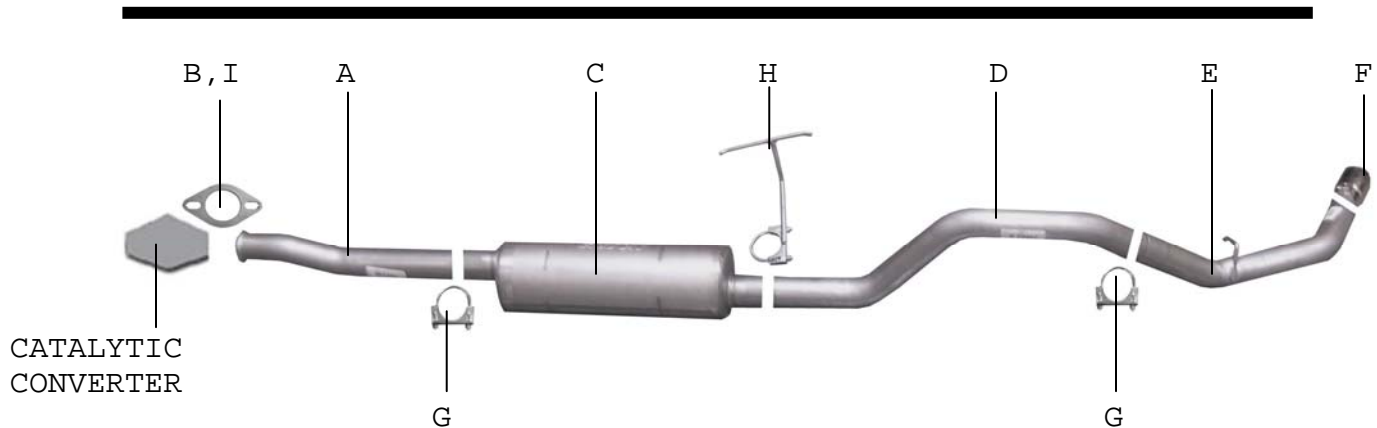

INSTRUCTION MANUAL
CAT-BACK SINGLE EXHAUST SYSTEM
98-06 FORD RANGER/MAZDA 2.5L-3.0L-4.0L 2/4WD
01-06 FORD RANGER 4.0L-EDGE 2/4WD
EXTENDED CAB, SHORT BED
PART# 19713



ITEM	PART #	QUANTITY	DESCRIPTION
A	700336	1	2-1/2" HEADPIPE
B	GP-102	1	2 BOLT FLANGE
C	788500	1	SUPERFLOW MUFFLER
D	25002-B	1	2-1/2" OVERAXLE TAILPIPE
E	25006	1	2-1/2" TURNOUT PIPE
F	500361	1	3" STAINLESS TIP
G	5757	2	2-1/2" CLAMP
H	4119	1	T-HANGER -REAR MUFFLER
I	BO-1034	1	BOLT KIT FOR FLANGE GP-102

2.5" SINGLE KIT WITH 3" STAINLESS TIP.

Thank you for purchasing our GIBSON EXHAUST SYSTEM for your vehicle. If you need further assistance, please do not hesitate to call our Technical Department at (800) 528-3044, Monday through Friday, 8:00 AM to 5:00 PM 0506

INSTALLATION INSTRUCTIONS #19713

WHEN INSTALLING THIS EXHAUST SYSTEM, MAKE SURE TO USE PROPER SAFETY PRECAUTIONS. USE JACK STANDS WHEN UNDER THE TRUCK, SET PARKING BRAKE, BLOCK TIRES, AND USE SAFETY GLASSES AND GLOVES. **DO NOT WORK WITH HOT PIPES!**

SUGGESTED TOOLS:

15mm SOCKET AND WRENCH, 9/16" SOCKET AND WRENCH, 1/2" SOCKET, 1/2" WRENCH, JACK STAND, HACKSAW, HI-TEMP GASKET SEALER



LAY OUT THE EXHAUST AND COMPARE PART NUMBERS. FOR AN EASIER REMOVAL OF THE STOCK EXHAUST CUT THE TAILPIPE BEHIND THE MUFFLER USING A HACKSAW. UNBOLT THE FACTORY FLANGE IN FRONT OF THE MUFFLER WITH OUT REMOVING THE FACTORY DOUGHNUT GASKET. YOU WILL RE-USE STOCK BOLTS. NOW REMOVE YOUR STOCK EXHAUST. LEAVE ALL RUBBER GROMMETS IN PLACE.



INSERT THE OVERAXLE TAILPIPE #D INTO THE OUTLET OF THE MUFFLER 1 1/2" TO 2" INTO THE MUFFLER AND ATTACH USING CLAMP #H. DO NOT TIGHTEN



SLIDE FLANGE #B ONTO HEADPIPE #A. BOLT HEADPIPE UP TO THE FACTORY FLANGE USING YOUR FACTORY HARDWARE.



SLIDE TURN OUT PIPE #E ONTO THE OVERAXLE PIPE. INSERT WELDED HANGER INTO FACTORY RUBBER GROMMET. USE CLAMP #G TO ATTACH PIPES TOGETHER. DO NOT TIGHTEN.



SLIDE MUFFLER ONTO THE HEADPIPE 1 1/2" TO 2". THE MUFFLER INLET IS LOOKING INTO THE LOUVERS. USE JACK STAND TO SUPPORT THE MUFFLER. ATTACH CLAMP #G AT THE INLET OF THE MUFFLER. THE MUFFLER OUTLET SHOULD BE POSITIONED AT ABOUT 12 O'CLOCK. DO NOT TIGHTEN



INSTALL THE STAINLESS STEEL TIP. USE ANY ALUMINUM OR STAINLESS STEEL CLEANER TO POLISH THE TIP. NOW TIGHTEN ALL CLAMPS, HANGERS, AND BOLTS.



ATTACH REAR MUFFLER HANGER #H ONTO OUTLET OF MUFFLER AND INSERT WELDED ROD INTO THE RUBBER GROMMETS. THE VERTICAL ROD OF HANGER #H WILL BE POSITIONED ON THE DRIVER SIDE OF THE MUFFLER OUTLET. DO NOT TIGHTEN.

MAKE SURE YOU HAVE A 1" CLEARANCE ON ALL PIPES FROM ALL BRAKE LINES, TIRES, SHOCKS, FUEL LINES, ETC...