



# INSTRUCTION MANUAL

## CAT-BACK SINGLE EXHAUST

98-01 DODGE TRUCK 3.9L, 5.2L, 5.9L, 2/4WD  
STANDARD & EXTENDED CAB, SHORT & LONG BED

PART # 316577

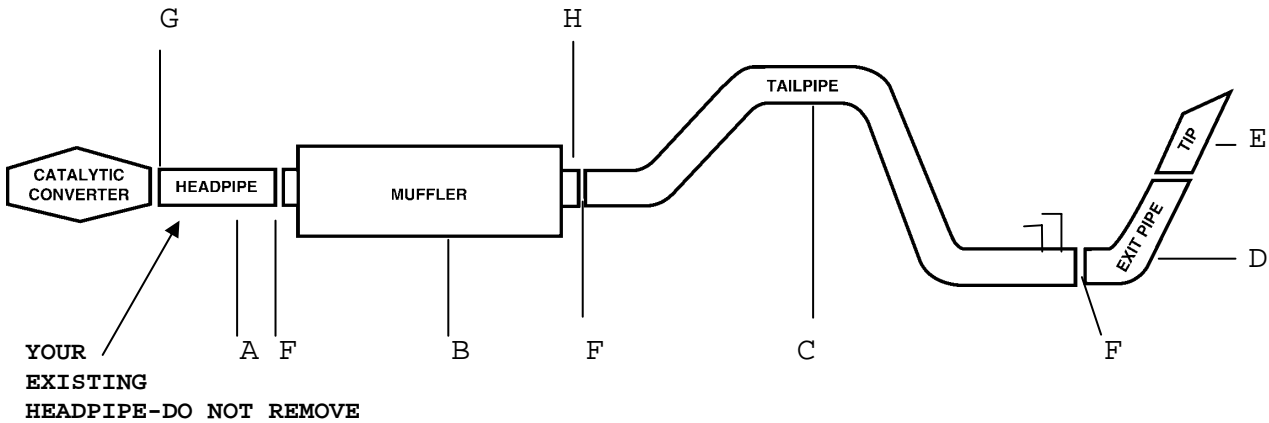

ITEM	PART #	QUANTITY	DESCRIPTION
A	2506	1	3" HEADPIPE
B	788025	1	SUPERFLOW MUFFLER
C	700341	1	3" OVERAXLE TAILPIPE
D	50032R	1	3" TURNOUT PIPE
E	500360	1	3-1/2" STAINLESS TIP
F	OHD300	3	3" CLAMP
G	5757	1	2-1/2" CLAMP
H	500354	1	REAR MUFFLER HANGER

**WILL NOT FIT HEAVY DUTY SERIES.  
WILL NOT FIT WITH TWO CONVERTERS.**

Thank you for purchasing our GIBSON EXHAUST SYSTEM for your vehicle. If you need further assistance, please do not hesitate to call our Technical Department at (800) 528-3044, Monday through Friday, 8:00 am to 5:00 P.M. 0705

# EXHAUST INSTALLATION #316577

WHEN INSTALLING THIS EXHAUST SYSTEM MAKE SURE TO USE PROPER SAFTEY PRECAUTIONS. USE JACK STANDS WHEN UNDER THE TRUCK, SET PARKING BRAKE, BLOCK TIRES AND USE SAFTEY GLASSES AND GLOVES.DO NOT WORK WITH HOT PIPES!

## SUGGESTED TOOLS:

HACKSAW, JACKSTAND,  $\frac{1}{2}$ " WRENCH, 9/16" SOCKET, 15MM SOCKET  
LAY OUT THE EXHAUST ON THE FLOOR SO IT LOOKS LIKE THE DRAWING.

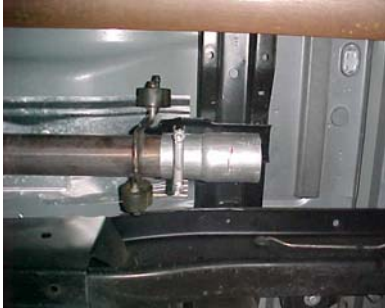

UNCLAMP EXHAUST IN FRONT OF STOCK MUFFLER. **IF YOU HAVE AN EXTENSION PIPE BETWEEN THE CONVERTER AND MUFFLER- DO NOT REMOVE!** LEAVE ALL RUBBER GROMMETS IN PLACE. INSTALL HANGERS AS PROVIDED. INSTALL HEADPIPE #A ONTO YOUR EXISTING STOCK FRONT PIPE AND CONNECT WITH CLAMP #G. USE JACKSTAND TO SUPPORT THE CONVERTER.



INSTALL THE OVERAXLE TAILPIPE #C TO THE MUFFLER AND CONNECT WITH CLAMP #F. BUT DO NOT TIGHTEN. SLIDE WELDED HANGERS INTO RUBBER GROMMETS.



CONNECT MUFFLER#B TO THE FRONT EXTENSION PIPE WITH THE LOUVERS FACING TOWARDS THE CONVERTER. USE A JACK STAND TO SUPPORT THE MUFFLER. CONNECT WITH CLAMP #F. DO NOT TIGHTEN. MUFFLER INLET IS LOOKING INTO THE LOUVERS.



CONNECT TURNOUT #D EXIT PIPE TO THE REAR OVERAXLE PIPE. ROLL TURNOUT PIPE UNTIL YOU HAVE IT AT THE CORRECT ANGLE FOR YOUR TRUCK AND CONNECT WITH CLAMP #F. BUT DO NOT TIGHTEN.



INSTALL HANGER #H AS PROVIDED. VERTICAL ROD ON HANGER #H SHOULD BE TO THE LEFT OF THE CENTER OF THE MUFFLER.



INSTALL STAINLESS STEEL TIP. CLAMP DOWN. WHEN YOU HAVE EVERYTHING IN PLACE, FIRMLY TIGHTEN ALL BOLTS AND CLAMP DOWN SECURELY. TO CLEAN STAINLESS STEEL TIP USE ANY STAINLESS STEEL OR ALUMINUM CLEANER.

**MAKE SURE YOU HAVE A 1" CLEARANCE ON ALL RUBBER BRAKE& FUEL LINES, SHOCK BOOTS, TIRE, ETC...**