

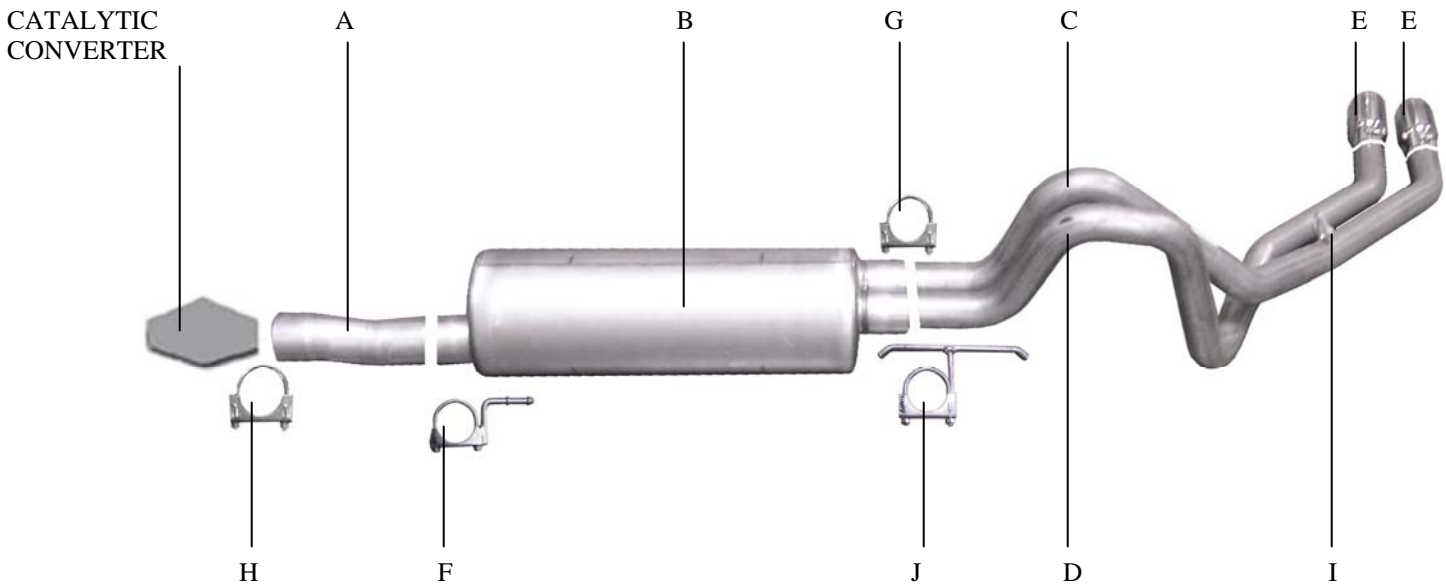

INSTRUCTION MANUAL

CAT-BACK STAINLESS DUAL SPORT TRUCK EXHAUST
 00-05 FORD EXCURSION 5.4L- 6.8L 2WD
PART # 69900



ITEM	PART#	QTY	DESCRIPTION
A	411-500455S	1	3" X 9" STAINLESS HEADPIPE
B	758250S	1	STAINLESS SUPERFLOW MUFFLER
C	412-700259S	1	2 1/4" PASS. STAINLESS OVERAXLE TAILPIPE
D	413-700260S	1	2 1/4" DRIVER STAINLESS OVERAXLE TAILPIPE
E	500370	2	3" STAINLESS TIP
F	40098	1	FRONT MUFFLER HANGER
G	5757	1	2 1/2" CLAMP
H	OHD300	1	3" CLAMPS
I	BO-906	1	BOLT KIT FOR TAILPIPE
J	40099	1	REAR MUFFLER HANGER

Thank you for purchasing our GIBSON EXHAUST SYSTEM for your vehicle. If you need any further assistance, please do not hesitate to call our Technical Department at 800-528-3044, Monday-Friday 8:00AM-5:00PM. 0506

INSTALLATION INSTRUCTIONS

PART #69900

WHEN INSTALLING THIS EXHAUST SYSTEM, MAKE SURE TO USE THE PROPER SAFETY PRECAUTIONS. USE JACK STAND WHEN UNDER TRUCK, SET PARKING BRAKE, BLOCK TIRES, AND USE SAFETY GLASSES AND GLOVES. DO NOT WORK WITH HOT PIPES!

SUGGESTED TOOLS:

15mm SOCKET, 9/16" SOCKET, 1/2" SOCKET, 1/2" WRENCH, JACK STAND, HACKSAW

LAY OUT THE GIBSON EXHAUST ON THE FLOOR SO IT LOOKS LIKE THE DRAWING AND COMPARE PART NUMBERS.
(NOTE: DRAWING IS ONLY FOR PLACEMENT OF PARTS)



1. UN-BOLT THE FACTORY EXHAUST IN FRONT OF THE FACTORY MUFFLER. FOR EASIER INSTALLATION CUT THE FACTORY TAILPIPE BEHIND THE MUFFLER AND USE A HACKSAW TO REMOVE THE MUFFLER AND HEADPIPE. NEXT REMOVE THE FACTORY REAR HANGER UNDERNEATH THE BUMPER. LEAVE ALL OTHER FACTORY RUBBER GROMMETS IN PLACE.

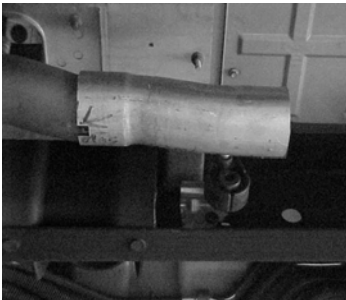

2. SLIP HEADPIPE #A ONTO THE FACTORY HEADPIPE. USE CLAMP #H TO ATTACH IT. DO NOT TIGHTEN.

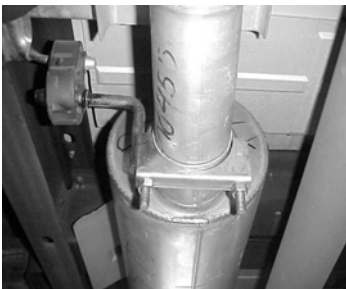

3. SLIP THE MUFFLER #B ONTO HEADPIPE #A NO LESS THEN 1- 1/2" AND NO MORE THEN 2". THE MUFFLER OUTLETS WILL BE LEVEL AT THE 12 O'CLOCK POSITION. THEN INSTALL HANGER #F ON THE INLET OF THE MUFFLER AND INSERT WELDED HANGER INTO RUBBER GROMMET. DO NOT TIGHTEN.

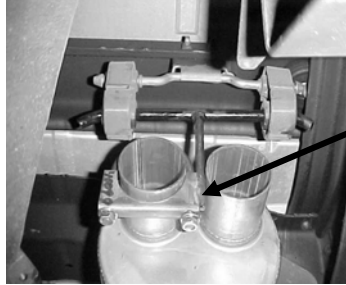

4. INSTALL HANGER #J ON THE DRIVER SIDE OUTLET OF MUFFLER WITH THE VERTICAL ROD IN BETWEEN THE TWO OUTLETS. DO NOT TIGHTEN



5. SLIP OVERAXLE PIPE #C ON THE PASSENGER SIDE OUTLET OF THE MUFFLER NO LESS THEN 1 1/2" AND NO MORE THEN 2". ATTACH TO MUFFLER USING CLAMP #G. DO NOT TIGHTEN. SLIP OVERAXLE PIPE #D INTO THE DRIVER SIDE MUFFLER OUTLET. AND ATTACH WITH HANGER #J. NOTE: DRIVER SIDE OVERAXLE TAILPIPE ROUTES UNDER PASSENGER SIDE OVERAXLE PIPE, ENDING UP IN FRONT OF PASSENGER SIDE OVERAXLE. ATTACH BOLT ASSEMBLY #I. DO NOT TIGHTEN



6. INSTALL YOUR STAINLESS STEEL TIPS TO YOUR DESIRED LOOK. USE ANY ALUMINUM OR STAINLESS STEEL CLEANER TO POLISH YOUR TIPS. NOW TIGHTEN ALL CLAMPS AND HANGERS.

MAKE SURE YOU HAVE A 1" CLEARANCE ON ALL BRAKE LINES, TIRES, SHOCK BOOTS, FUEL LINES, ETC...

INSTALLATION INSTRUCTIONS

PART #69900

WHEN INSTALLING THIS EXHAUST SYSTEM, MAKE SURE TO USE THE PROPER SAFETY PRECAUTIONS. USE JACK STAND WHEN UNDER TRUCK, SET PARKING BRAKE, BLOCK TIRES, AND USE SAFETY GLASSES AND GLOVES. DO NOT WORK WITH HOT PIPES! DUE TO VEHICLE TOLERANCES, SOME EXHAUST KITS MAY REQUIRE MORE ADJUSTMENTS THAN OTHERS.

SUGGESTED TOOLS:

15mm SOCKET, 9/16" SOCKET, 1/2" SOCKET, 1/2" WRENCH
1ST TIME INSTALLER, MAY REQUIRE 2 PEOPLE

1. Lay out the GIBSON EXHAUST SYSTEM on the floor so it looks like the drawing. (NOTE: Drawing is not exact but for placement of parts only!).
2. Unbolt stock exhaust system in front of muffler. Remove factory exhaust leaving all rubber grommets in place. #A as shown on picture #1.
3. Connect headpipe to stock headpipe and clamp using #H.(DO NOT TIGHTEN).
4. Connect muffler with inlet towards head pipe. Outlets of muffler will be at the top closest to the frame. Use #F hanger to connect muffler to headpipe and hanger #J at rear of muffler #4 as seen on picture #2 and #4. (NOTE: Hanger clamps on driver side.) (DO NOT TIGHTEN!)
5. Install overaxle pipe #C and use clamp #G into the passenger side muffler outlet.DO NOT TIGHTEN.
6. Install overaxle pipe #D use clamp #J into the driver side muffler outlet.DO NOT TIGHTEN.
7. Use #I bolt kit and connect over axle pipes #C and #D together. (DO NOT TIGHTEN.)
8. After everything is installed, line up pipes and clamp all bolts down securely. Make sure you have a 1" clearance on all pipes from rubber brake lines, shock boots, etc.
9. NOTE: Remove last rear hanger on vehicle because it is not being used. Refer to picture #8.
10. Install stainless tips to desired look, to clean the tips use a scotch brite pad and any stainless steel or aluminum cleaner.

SPECIAL NOTES

- **LEGAL STATUS:** THIS GIBSON EXHAUST SYSTEM IS IN COMPLIANCE WITH VC27156 WHEN INSTALLED BEHIND THE CATALYTIC CONVERTER. NO EXEMPTION NUMBER IS NEEDED.

TECH NOTES

1. IF THE HANGER IN FRONT OF THE MUFFLER WILL NOT SIT LEVEL OR IN THE RUBBER GRAUMENT. OR THE MUFFLER WILL NOT SIT LEVEL. SEND A #700257 HEADPIPE TO ROTATE MUFFLER IN A HIGHER POSITION. THE NOTCH IS LOCATED AT A DIFFERENT POSITION. SHAWN 3/29/00
2. IF THE REAR T-HANGER WILL NOT FIT IN BETWEEN THE OUTLETS OF MUFFLER BECAUSE OF 1\2" ROD USED. SEND NEW RE-DESIGNED 3\4" ROD HANGER NO CHARGE. UNLESS CUSTOMER IS WILLING TO GRIND THE HANGER FOR CLEARANCE. SHAWN 3/29/00