

# INSTALLATION INSTRUCTIONS AND PARTS LIST

MODEL: 583098, 583102, 583108, 583114, 583125, 584098, 584102, 584114, 584125 O-MEGA II 6" OVAL  
STEPS  
UNIVERSAL APPLICATION

1. READ INSTRUCTIONS COMPLETELY AND CHECK TO MAKE SURE THAT ALL REQUIRED PARTS (LISTED ON THE SERVICE PARTS LIST) ARE ON HAND BEFORE STARTING THE INSTALLATION.
2. FOLLOW THE INSTRUCTIONS INCLUDED WITH THE SPECIFIC BRACKET PACKAGE THAT YOU ARE USING, TO MOUNT THE BRACKETS TO YOUR VEHICLE.
3. BEFORE ATTACHING THE O-MEGA STEPS TO THE BRACKETS, PLACE THE STEP PADS (ITEM #2) ON TOP OF THE STEP PLATES. USE THE TABLE ON SHEET #2, AS A GUIDE TO POSITION THE STEP PAD FOR YOUR PARTICULAR VEHICLE. WHEN INSTALLING THE PADS ON THE STEPS, DRILL (5) 1/8" HOLE USING THE STEP PAD AS A GUIDE. ATTACH WITH (5) 8-18X1/2" TEK SCREWS (ITEM #6) PROVIDED. REPEAT FOR ALL STEP PADS. (NOTE: DUE TO THE SHORTNESS OF SOME BOXES, MOUNT THE BOX STEP PAD FIRST, APPROXIMATELY 1/2" FROM THE END CAP AND THEN MOUNT THE MIDDLE STEP PAD ACCORDINGLY.)
4. INSTALL THE REQUIRED NUMBER OF SQUARE HEAD BOLTS INTO THE DESIGNATED SLOTS IN THE BOTTOM OF THE STEP PLATES.
5. INSTALL THE END CAPS (ITEM #3) AS SHOWN IN *fig. 1*, TIGHTENING THE NUTS TO 5 LB FT.
6. POSITION THE O-MEGA STEP ON THE MOUNTING BRACKETS SO THAT THE SQUARE HEAD SCREWS (ITEM #4) ARE LOCATED IN THE SLOTS OF THE MOUNTING BRACKETS AND THE STEP IS CENTERED, FRONT TO REAR, ON THE VEHICLE. INSTALL 5/16" SERRATED FLANGE NUTS (ITEM #5) ON THE SQUARE HEAD SCREWS (ITEM #4) AND TIGHTEN TO 19 LB FT.

## SERVICE PARTS LIST

ITEM	PART NO.	QTY	DESCRIPTION
1	553074	2	EXTRUSION-AL,95.0,OMEGA STP,SILVEER
1	553075	2	EXTRUSION-AL,99.0,OMEGA STP,SILVER
1	553076	2	EXTRUSION-AL,105.0,OMEGA STP,SILVER
1	553077	2	EXTRUSION-AL,111.0,OMEGA STP,SILVER
1	553078	2	EXTRUSION-AL,122.0,OMEGA STP,SILVER
1	553062	2	EXTRUSION-AL,95.0,OMEGA STP,BLACK
1	553063	2	EXTRUSION-AL,99.0,OMEGA STP,BLACK
1	553065	2	EXTRUSION-AL,111.0,OMEGA STP,BLACK
1	553066	2	EXTRUSION-AL,122.0,OMEGA STP,BLACK
2	107957	6	ALUM,STP-PAD,BLK,OMEGA-STEP
3	107956	4	CAP-END,PLSTC,2.95 X 6.70
4	106880	28	SCREW-SQ HD,5/16-18 X 1,MAGNIGUARD
5	102680	28	NUT-SERR FLG,HX,SST,WX,5/16-18
6	107958	30	SCREW-PPH,TEK,#8-18 X 1/2",SST,BZP



## STEP PAD LOCATION GUIDE



VEHICLE MODEL	PAD A	PAD B
SILVERADO/SIERRA DOUBLE CAB	14-3/4	46-3/4
SILVERADO/SIERRA EXTENDED CAB	14-3/4	41-3/4
SILVERADO/SIERRA CREW CAB	14-3/4	54-1/4
CHEVROLET EXPRESS VAN & GMC SAVANA VAN	7-1/2	N/A
RAM QUAD CAB	10-1/2	46
RAM CREW CAB	10-1/2	48
RAM MEGA CAB	10-1/2	52-1/16
FORD F150 SUPER CAB	18-1/4	46-1/4
FORD F150 SUPER CREW CAB	18-1/4	56-1/2
FORD F150 SUPER CREW CAB	18-1/4	56-1/2
FORD SUPER DUTY SUPER CAB	6-7/8	39-1/16
FORD SUPER DUTY CREW CAB	6-7/8	52-7/8
FORD	7-1/2	N/A

**NOTE: THE ABOVE PAD LOCATIONS ARE ONLY SUGGESTIONS AND MAY BE PLACED AT THE PURCHASERS DISCRETION.**

# INSTALLATION INSTRUCTIONS AND PARTS LIST

## MODEL 570829 W2W MEGA STEPS BRACKETS:

2008 AND NEWER FORD SUPER DUTY SUPER CAB PICKUPS  
2008 AND NEWER FORD SUPER DUTY CREW CAB PICKUPS



1. READ INSTRUCTIONS COMPLETELY AND CHECK TO MAKE SURE THAT ALL REQUIRED PARTS (LISTED ON SERVICE PARTS LIST) ARE ON HAND BEFORE STARTING THE INSTALLATION.
2. EXISTING MOUNTING HOLE PATTERNS ARE LOCATED ON THE PINCH WELD AND INTERIOR WALL OF THE ROCKER PANEL. THESE MOUNTING HOLE PATTERNS MUST BE USED FOR THIS INSTALLATION PER THE FOLLOWING INSTRUCTIONS.
  - 2.1. STARTING AT THE FRONT, INSTALL 5/16" MULTI THREAD U-NUTS (ITEM #6) IN THE TOP REAR HOLE OF THE FIRST, SECOND AND THIRD PATTERNS AND IN THE FRONT TOP HOLE OF THE FIFTH OR REAR PATTERN AS SHOWN. INSTALL THESE U-NUTS SO THAT THE THREADS ARE TO THE INSIDE OF THE ROCKER PANEL. (THIS IS DONE BY INSERTING THE THREADED HALF OF THE U-NUT THRU THE LARGE ACCESS HOLES AND SLIDING THE U-NUT TOWARDS THE ROUND HOLE UNTIL IT SEATS IN THE ROUND HOLE).
3. ATTACH THE CAB MOUNTING BRACKETS (ITEM #2 & #3) TO THE VEHICLE. **(NOTE: THE FRONT MOUNTING BRACKET, ITEM #2, HAS A 3/16" OFFSET AT THE TOP OF THE BRACKET).**
  - 3.1. POSITION THE BRACKETS ON THE VEHICLE SO THAT THE TOP HOLE LINES UP WITH THE MULTI THREAD U-NUT AND THE BOTTOM HOLE LINES UP WITH THE HOLE IN THE PINCH WELD. ATTACH THE TOP OF THE BRACKET WITH A 5/16" X 1.00" ZINC PLATED HEX HEAD CAP SCREW (ITEM #7) AND 5/16" ZINC PLATED FLAT WASHER (ITEM #8). ATTACH THE BOTTOM OF THE BRACKET TO THE PINCH WELD WITH A 5/16" X 1.00" BLACK PLATED HEX HEAD CAP SCREW (ITEM #9), 5/16" BLACK PLATED FLAT WASHER (ITEM #10) AND 5/16" SERRATED FLANGE NUT (ITEM #5). LEVEL THE BRACKETS AND TIGHTEN THE FASTENERS TO 19 LB FT.
4. ATTACH THE STEP (ITEM #1) TO THE MOUNTING BRACKETS.
  - 4.1. INSERT FIVE (5) 5/16" SQUARE HEAD SCREWS (ITEM #4) IN THE CENTER SLOT ON THE UNDER SIDE OF THE STEP. (THE FRONT FOUR (4) SETS OF FASTENERS ATTACH THE STEP TO THE CAB MOUNTING BRACKETS AND THE EXTRA SCREW WILL BE USED TO ATTACH TO THE REAR MOUNTING BRACKET).
  - 4.2. POSITION THE STEP ON THE MOUNTING BRACKETS SO THAT THE SQUARE HEAD SCREWS ARE LOCATED IN THE SLOTS OF THE MOUNTING BRACKETS AND THE REAR OF THE STEP IS ABOUT EVEN WITH THE FRONT METALLIC FLANGE OF THE REAR WHEEL WELL.
  - 4.3. LOCATE THE STEP, IN AND OUT, AS DESIRED, INSTALL 5/16" SERRATED FLANGE NUTS (ITEM #5) ON THE SQUARE HEAD SCREWS AND TIGHTEN TO 19 LB FT.

**LIVERNE**  
TRUCK EQUIPMENT

(A LIVERNE Company)

1200 E. Birch Street Brandon, SD 57005

551644 SHEET 1 29MAY07

5. ATTACH THE REAR MOUNTING BRACKET (ITEM #11) AGAINST THE TOP OF THE VEHICLE SPRING HANGER,SO THAT THE FLAT SURFACES MEET.
- 5.1. INSTALL 7/16-14X1-1/2(ITEM # 13) DOWN THRU THE TOP OF BRACKET(ITEM #12) AND THE BRACKET.  
 ATTACH A.7/16-14 SERRATED FLANGE NUT AND WASHER(ITEM#14 AND#15)
- 5.2. INSTALL THE BOTTOM MOUNTING BRACKET (ITEM #12) SO THAT THE VERTICAL SURFACES MEET.INSTALL 5/16-18 1.00 HEX HEAD CAP,WASHER AND SERRATED FLANGE NUT(ITEM #7,8,5).INSTALL MEGA STEP ON TOP OF LOWER ,ALIGN WITH FRONT STEP,TIGHTEN DOWN WITH 5/16-18 SERRATED FLANGE NUTS.
- 5.3 .TIGHTEN 5/16 FASTERNERS TO 19 LB FT.
- 5.4 TIGHTEN 7/16 FASTERNERS TO 40 LB FT.

### SERVICE PARTS LIST

ITEM	PART NO.	QTY	DESCRIPTION
1		2	MEGA STEP BOARD ASSEMBLY (SOLD SEPARATELY) LENGTH WILL VARY DEPENDING ON APPLICATION
2	551562	2	BRKT- MTG, STEP, SUPER DUTY PICKUP, FRONT
3	551563	6	BRKT- MTG, STEP, SUPER DUTY PICKUP
4	106880	10	SCREW-SQUARE HEAD, 5/16_18 UNC
5	102680	32	NUT-SERRATED FLANGE, HEX, SST, 5/16-18 UNC
6	104264	8	U-NUT- MULTI THREAD, 5/16-18 UNC, STL, BLK
7	100647	12	SCREW- HEX HEAD CAP, 5/16_18 UNC X 1.00".ZP
8	100034	12	WSHR-PL, A, STL, 5/16,.375 ID X .875 OD X .083 THK, ZP
9	106997	8	SCREW- HEX HEAD CAP, 5/16_18 UNC X 1.00", SST, BZP
10	106998	8	WSHR-PL, A, SST, 5/16,.375 ID X .875 OD X .083 THK, BZP
11	551642	2	BRKT-MTG, MS, W2W, 12 GA, 2.00", FORD SPR DTY,UPPER
12	551643	2	BRKT-MTG, MS, W2W, 7 GA, 2.50", FORD SPR DTY,LOWER
13	100070	2	SCREW- HEX HEAD CAP, 7/16-14X1-1/2", ZP
14	103737	2	NUT-SERRATED FLANGE,HEX7/16-14 UNC,ZP
15	100081	2	WSHR-FL, A, STL,7/16,.464X1.243X.064 THK, ZP



(A LIVERNE Company)

1200 E. Birch Street Brandon, SD 57005

551644 SHEET 2 29MAY07

SERVICE PARTS LIST

BRACKET NO. - 570829

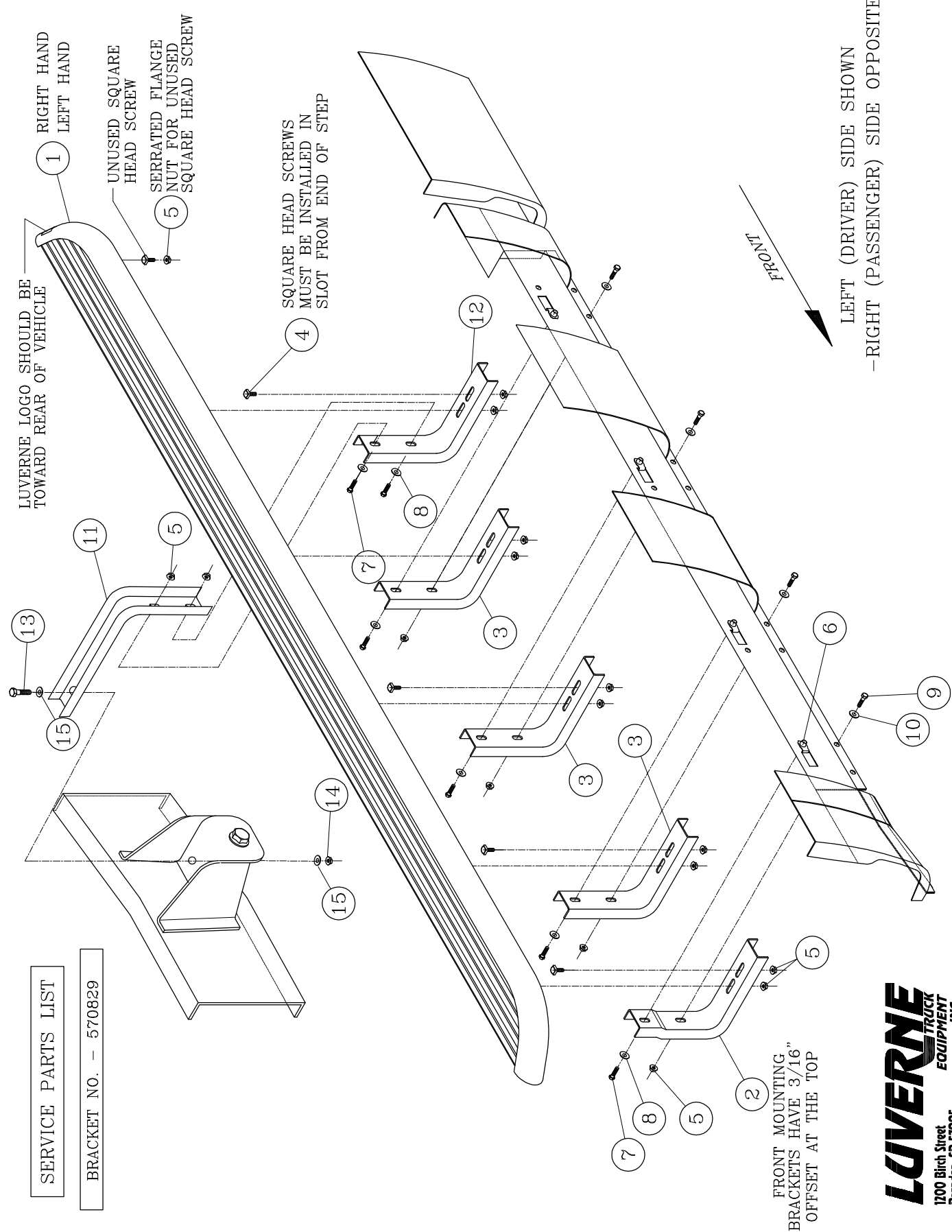

LUVVERNE LOGO SHOULD BE TOWARD REAR OF VEHICLE

RIGHT HAND  
LEFT HAND

UNUSED SQUARE  
HEAD SCREW

SERRATED FLANGE  
NUT FOR UNUSED  
SQUARE HEAD SCREW

SQUARE HEAD SCREWS  
MUST BE INSTALLED IN  
SLOT FROM END OF STEP

FRONT

LEFT (DRIVER) SIDE SHOWN  
-RIGHT (PASSENGER) SIDE OPPOSITE-

FRONT MOUNTING  
BRACKETS HAVE 3/16"  
OFFSET AT THE TOP

**LUVVERNE**  
TRUCK  
EQUIPMENT  
INC.  
1700 Birch Street  
Brandon, SD 57005