



52mm TPI THROTTLE BODIES for 1985-88 and 1989-92 CHEVROLET P/N's 112-502 and 112-506
58 mm TPI THROTTLE BODIES for 1985-88 and 1989-92 CHEVROLET P/N's 112-503 and 112-507
52 mm LT1 THROTTLE BODIES for 1993 and 1994-97 CHEVROLET P/N's 112-504 and 112-508
58 mm LT1 THROTTLE BODIES for 1993 and 1994-97 CHEVROLET P/N's 112-505 and 112-509

Installation and Adjustment Instructions

INTRODUCTION:

Congratulations on your purchase of a Holley Throttle Body Kit! Holley Performance Products cannot and will not be responsible for any alleged or actual engine or other damage, or other conditions resulting from misapplication of the products described herein. However, it is our intent to provide the best possible products for our customer; products that perform properly and satisfy your expectations. Should you need information or parts assistance, please contact our Technical Service Department at 1-270-781-9741, Monday through Friday, 7 a.m. to 5 p.m. Central Time; please have the part number of the product you purchased when you call.

WARNING! These instructions must be read and fully understood before beginning installation. Failure to follow these instructions may result in poor performance, vehicle damage, personal injury, or death. If these instructions are not fully understood, installation should not be attempted.

APPLICATIONS:

The products contained in this kit are designed to be a high performance replacement for the LT1 and TPI throttle bodies. To achieve maximum performance with the Holley large bore throttle body, Holley recommends the upper manifold be bored out to match the exact millimeter bore of the throttle body.

THROTTLE BODY KIT CONTENTS:

- Throttle Body Assembly Bolts
- Throttle Body Gasket
- 4 - Throttle Body Mounting

INSTALLATION:

1. Check and record the voltage of the throttle position sensor. Using a paper clip or pushpin, find the output on the TPS (Blue wire—5 volts).
2. Disconnect the negative battery terminal.
3. Remove the throttle body air inlet tube and disconnect the two water lines from the under side of the throttle body.
4. Disconnect all vacuum lines, electrical connectors, and throttle and cruise control cables from the throttle body.
5. Remove the 4-10mm throttle body mounting bolts. Slowly remove the throttle body from the intake manifold ensuring that no other connections are hindering removal.
6. Remove the 7 #20 torx head screws from the water crossover manifold on the underside of the O.E. throttle body. Transfer the water crossover manifold and torx screws to the new throttle body.
7. Remove the throttle position sensor from the throttle body. Install the throttle position sensor on the new throttle body. Use the existing screws. To ensure proper operation of the new throttle body, you may need to adjust the throttle position sensor to the original voltage that was on the stock throttle body. The OEM is not adjustable. You may have to slot the TPS to properly adjust with a cordless drill and bit.

NOTE: Ensure that the throttle is fully seated to the manifold to avoid leaks.

8. Install the new throttle body onto the intake manifold using the provided gaskets and bolts. Torque to 18 ft. lbs.
9. Reconnect all vacuum lines, electrical connectors, and throttle and cruise control cables from the throttle body.
10. Check for wide-open throttle with the pedal before installing the bellows.
11. Reconnect the throttle body air inlet tube and the two water lines from the under side of the throttle body.
12. Reinstall the negative battery terminal.
13. Refill the coolant tank to allow for any lost coolant.
14. Start the engine. The idle adjustment screw is accessible from the back side of the throttle body. If any idle adjustments are required, refer to the factory specs. A scan tool may be needed to make these adjustments.

For 1992 & 1993 Corvettes and Camaro/Firebird with the ASR option:

IMPORTANT! The adjuster assembly cables must always be adjusted each time the adjuster assembly is removed and replaced to insure optimum system performance. Always make sure the cable sheaths are extended to full length before performing the adjustment procedure.

REMOVAL:

1. Remove the adjuster assembly splash cover retaining screw (VIN P).
2. Remove the adjuster assembly splash cover and foam insert.
3. Remove the cable cam cover.

4. Disconnect the cruise control cable from the cruise actuator.

ADJUST:

1. Depress the reset tab on the throttle body and accelerator pedal cables (Figures 1 & 2) and fully extend the cable sheaths.
2. Insert a 1/8" drill bit into the adjuster assembly alignment hole (Figure 3).

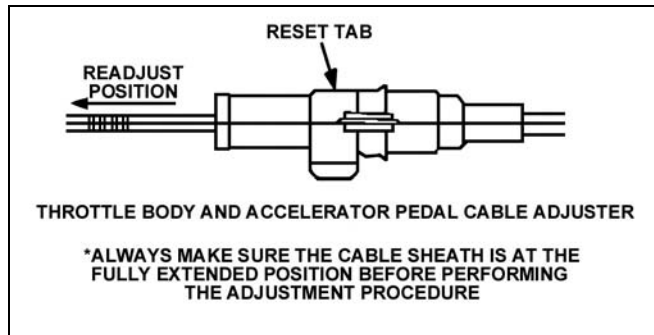

Figure 1

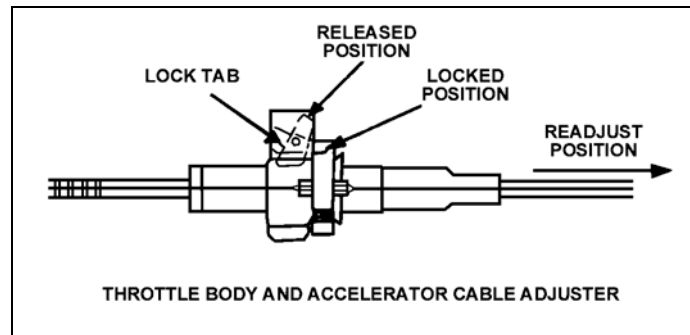

Figure 2

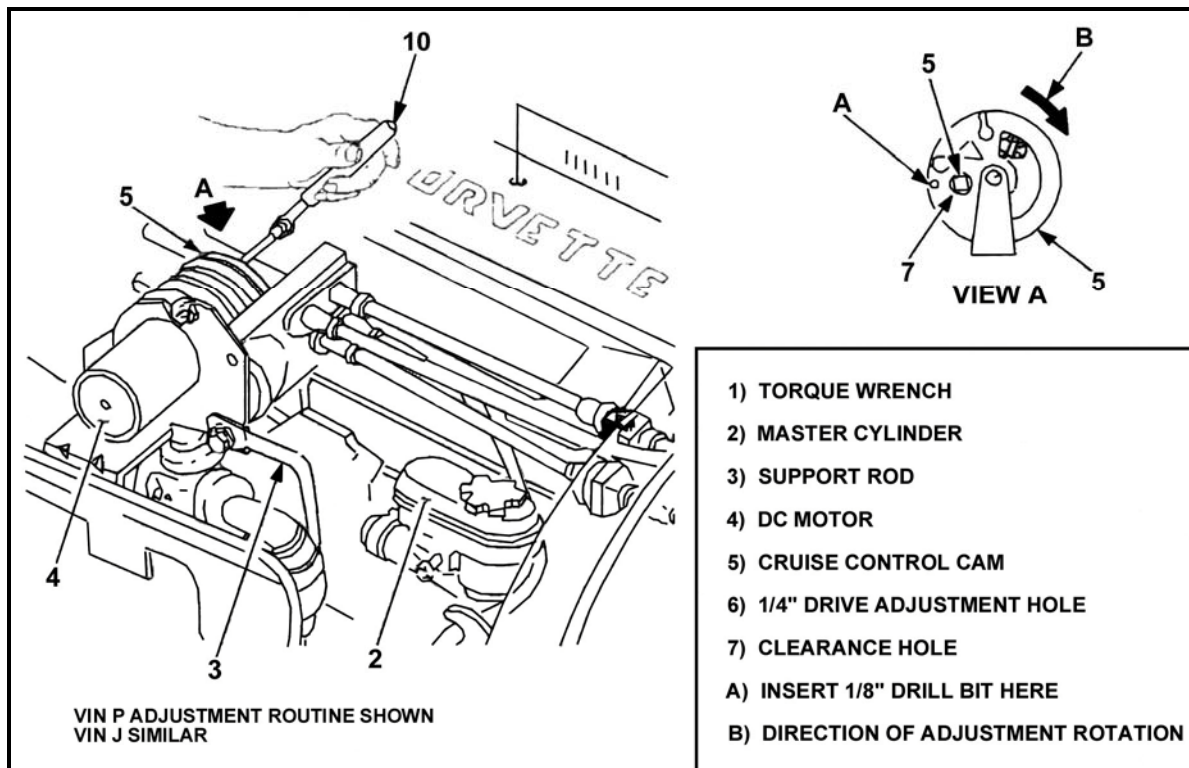

Figure 3

IMPORTANT! To ensure that improper adjustment does not occur, make sure that the drill bit does not make contact with the adjuster assembly gear.

3. To align the cams, it may be necessary to turn the cams approximately 1/8 turn by hand.
4. Insert the 1/4" drive torque wrench with extension through the cruise control cam into the accelerator pedal cam (Figure 3).
5. To obtain a torque of 8 N-m (71 lb./in.) for VIN P and 4 N-m (35 lb./in.) for VIN J, turn the torque wrench clockwise, resulting in several clicks of the adjusters being heard.
6. Remove the torque wrench and extension.
7. To automatically adjust the accelerator pedal cable, fully depress the accelerator pedal.
8. Remove the 1/8" drill bit.
9. The cruise control cable is to be adjusted with the cable installed into the actuator bracket.
10. Pull the actuator assembly end of the cable toward the actuator without moving the actuator bracket.
11. If one of the five holes in the actuator assembly tab lines up with the cable pin, push the pin through the hose and connect the pin to the tab with the retainer.
12. If the tab hole does not line up with the pin, move the cable away from the actuator assembly until the next closest tab holes line up. Connect the pin to the tab with the retainer.

IMPORTANT! DO NOT stretch the cable to connect a particular tab hole to the pin. This may prevent the engine from returning to idle speed.

199R-10020-2

Date: 11-5-01